

ASSEMBLY, INSTALLATION & SERVICING MANUAL FOR AMBI RAD VISION® VSO & VSXO RANGE OF RADIANT TUBE HEATERS



INDEX

Section

Introduction and Document Index	
Installation Requirements -----	1
Assembly Instructions -----	2
Commissioning Instructions -----	3
Servicing Instructions -----	4
Spare Parts -----	5
Fault Finding Guide -----	6
Replacing Parts -----	7
User and Operating Instructions -----	8

WARNINGS

AmbiRad equipment must be installed and maintained in accordance with the relevant provisions of the Gas Safety (Installations and Use) Regulations 1998 for gas fired products. Due account should also be taken of any obligations arising from the Health and Safety at Works Act 1974 or relevant codes of practice. In addition the installation must be carried out in accordance with the current IEE wiring regulations (BS 7671), BS 6896 (Industrial & Commercial) and any other relevant British Standards and Codes of Practice by a qualified installer. All external wiring MUST comply with the current IEE wiring regulations.

Introduction.

Welcome to the new range of high efficiency AmbiRad Vision radiant tube heaters. Local regulations may vary in the country of use and it is the installers responsibility to ensure that such regulations are satisfied.

All installation, assembly, commissioning and service procedures must be carried out by suitably qualified and competent persons to the statutory regulations in the country of use.

When assembling, installing, commissioning and servicing is undertaken on radiant tube heaters specified in these instructions, due care

and attention is required to ensure that working at height regulations are adhered to at the mounting heights specified.



PLEASE READ this document prior to installation to familiarise yourself with the components and tools you require at the various stages of assembly.

All Dimensions shown are in mm unless otherwise stated.

The manufacturer reserves the right to alter specifications without prior notice.

Document Index.

1 Installation Requirements

- 1.1 Health & Safety
- 1.2 Model Definitions
- 1.3 Heater Suspension
- 1.4 Wall Mounting
- 1.5 Herringbone Systems
- 1.6 Clearance to Combustibles
- 1.7 Gas Connection & Supply
- 1.8 Electrical Connections
- 1.9 Ventilation Requirements
 - 1.9.1 Unflued Radiant Heater
 - Mechanical Ventilation
 - Natural Ventilation
 - 1.9.2 Flued Radiant Heater
 - Mechanical Ventilation
 - Natural Ventilation
- 1.10 Flue & Combustion Air Inlet Options
 - 1.10.1 Important Information
 - 1.10.2 Flue Installation
 - 1.10.3 Condensation Considerations
 - 1.10.4 Flue/Tailpipe Connections
- 1.11 Technical Details

2 Assembly Instructions

- 2.1 Tools Required
- 2.2 Assembly Notes
 - 2.2.1 Tubes
 - 2.2.2 Turbulators
 - 2.2.3 Brackets
 - 2.2.4 Couplers
 - 2.2.5 U Bend
 - 2.2.6 Reflectors
 - 2.2.7 End Caps
 - 2.2.8 Burner Assembly
 - 2.2.9 Heat Exchanger Assembly
 - 2.2.10 HB Damper Assembly
 - 2.2.11 Fan Assembly
 - 2.2.12 End Moulding Fixing
 - 2.2.13 HB Manifold Assembly
 - 2.2.14 Detailed Assembly Drawings

3 Commissioning Instructions

- 3.1 Tools Required
- 3.2 Balancing the Herringbone System
- 3.3 Commissioning chart

4 Servicing Instructions

- 4.1 Tools Required
- 4.2 Burner Description
- 4.3 Burner Removal
- 4.4 Burner Gas Injector Servicing
- 4.5 Burner Head and Electrode Servicing
- 4.6 Combustion Fan Assembly Unitary Heater
- 4.7 Combustion Fan Assembly Powered Burner
- 4.8 Radiant Tube Servicing
- 4.9 Heat Exchanger Servicing
- 4.10 Reflector Servicing
- 4.11 Inspection of Flue
- 4.12 Re-commissioning after Service

5 Spare Parts

6 Fault Finding Guide

7 Replacing Parts

- 7.1 Burner Controller Replacement
- 7.2 Air Pressure Switch Replacement
- 7.3 Gas Valve Replacement

8 User and Operating Instructions

- 8.1 To Start Heater
- 8.2 To Switch Off Heater
- 8.3 Routine Maintenance Between Service Intervals
- 8.4 Frequency of Servicing

1. Installation Requirements.

 Isolate any electrical supply to the heater and controller before proceeding.

1.1 Health and Safety

AmbiRad heaters must be installed in accordance with the relevant provisions of the Gas Safety (Installations and Use) Regulations 1998. Due account should also be taken of any obligations arising from the Health and Safety at Works Act 1974 or relevant codes of practice. In addition the installation must be carried out in accordance with the current IEE wiring regulations (BS 7671), BS 6896 (Industrial & Commercial) and any other relevant British Standards and Codes of Practice by a qualified installer. Isolate all electrical supplies to the heater & controller before proceeding.

For your own safety we recommend the use of safety boots and leather faced gloves when handling sharp or heavy items. The use of protective eye wear is also recommended.

1.2 Model Definitions

VSOUT = AmbiRad Vision U Tube Unitary heater with painted induced burner, ID Fan, aluminised steel reflectors, end caps, insulation, tube over shields, painted canopies and optional end covers.

VSOUH = AmbiRad Vision U Tube Herringbone heater with painted induced burner, Damper, aluminised steel reflectors, end caps, insulation, tube over shields, painted canopies and optional end covers.

VSXO = AmbiRad Vision High efficiency U Tube heater with forced burner, recuperative heat exchanger, aluminised steel reflectors, end caps, insulation, tube over shields, painted canopies and optional end covers.

1.3 Heater Suspension

 **The heater must be suspended by ALL of the suspension brackets.**

 See fig 1.b. Attachment to the heater support lugs should be made by a 'speed link', D shackle or in the case of drop rods, a closed formed hook. The hanging attachments to overhead steelwork etc. must be purpose made to good sound engineering practice or of a proprietary type fixing. They must be adequately fixed and designed to carry the whole weight of the heater. In the event of suitable roof steelwork being unavailable, additional steelwork should be fitted to enable vertical hangers to be used for suspending the heaters.

If there are any doubts as to the strength or suitability of roof steelwork to which heaters are to be suspended, please refer to a Consultant, Architect or owner of the building. The minimum mounting heights for AmbiRad heaters are given in the table below.

Model	MINIMUM Mounting Height (m)	
	Horizontal	Inclined / wall mounted
15	4.4	3.9
20	4.9	4.4
25	5.4	4.7
30	6.3	5.5
35	6.5	5.7
40	6.9	6.0
45	7.3	6.5
50	7.8	6.9

1.4 Wall Mounting

These radiant tube heaters can be wall mounted using the appropriate bracket (AmbiRad part no WMB-13-22-38).

When using the wall mounting brackets the heater must be inclined at an angle between 30° and 35°.

Table 1 Angle Mounting

Heater Size	Required angle	U Tube	
		Chain length	Eyebolt position
15 - 50	30-35°	12 links	1

Figure 1.a. Angle Mounting using the Wall mounting bracket

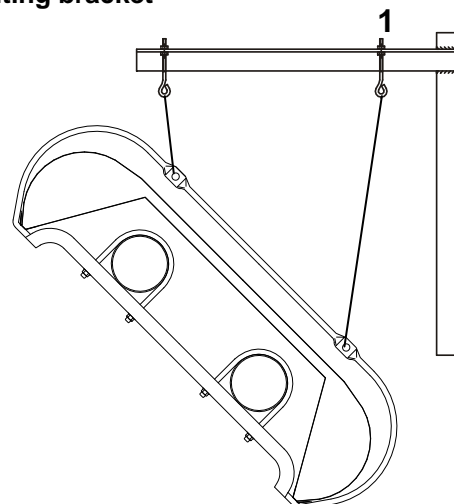
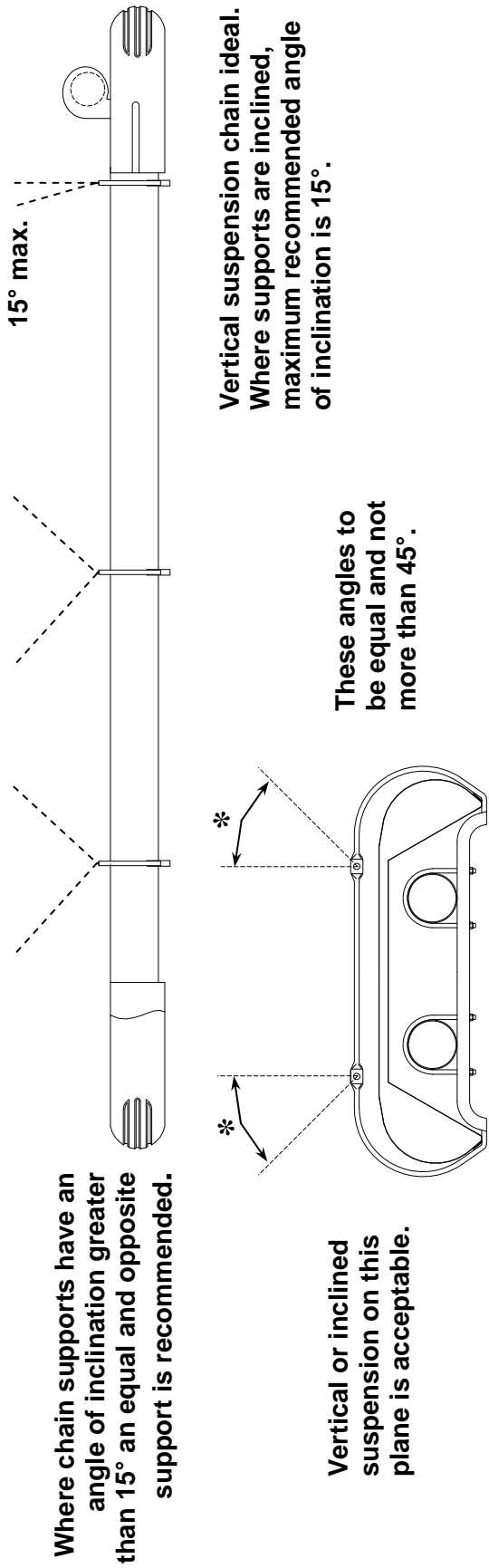
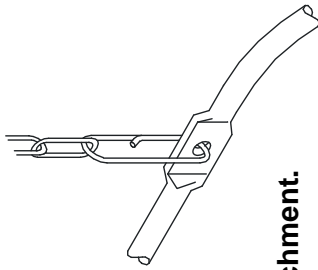

Figure 1.b. Recommended Methods of Heater Suspension.



ON U TUBE VARIANTS THE HEATER SHOULD SLOPE DOWNWARDS TOWARDS THE RETURN BEND BY APPROX. 10mm FOR BOTH HORIZONTAL AND WALL MOUNTED INSTALLATIONS.



Typical Speedlink attachment.

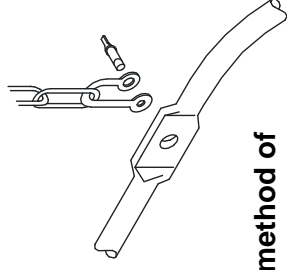

Shackle method of attachment. Pin must be tightened by pliers.

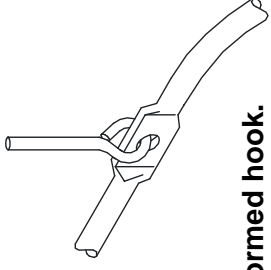

Drop rod with formed hook. note. hook or eyebolt must be closed tight.

1.5 Herringbone Systems (VSOUH).

The manifold system should be arranged to fall slightly in the direction of the vacuum fan. This ensures that any condensation formed in the manifold on cold start and cool down is not trapped or allowed to drain back into the heater unit. This allows condensate to flow towards the condensate trap located at the vacuum fan end of the manifold system. (See figure 2a below for condensate trap arrangement).

The manifold should be supported by chain, stainless steel flexible wire, or other flexible means from the roof structure to allow movement caused by thermal expansion. For 100mm diameter manifold the maximum distance between supports is 2.4m and 3.0m for 150mm diameter.

Flexible couplers (supplied by AmbiRad) must be inserted within the manifold system to allow linear expansion to take place and prevent stress and strain on the system.

 The manifold must be supported either side of the flexible coupler.

The exhaust flue should be adequately supported from the building structure and installed in accordance with the British Standard Code of Practice BS 5440 Part 1 – Installation and maintenance of flues and ventilation for gas appliances of rated input not exceeding 70kW net (1st, 2nd and 3rd family gases)

A condensate trap assembly must be provided at the end of the manifold system before the hot gas vacuum fan.

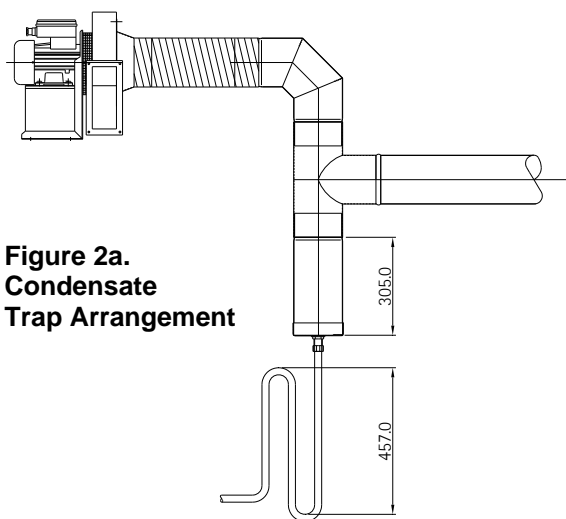

**Figure 2a.
Condensate
Trap Arrangement**

The minimum depth of the condensate collecting chamber shall be 305mm and the minimum depth of the condensate drain pipe

'U' trap shall be 457mm deep. The end cap of the collecting chamber to be fitted with a flush flanged tank connector. Any protrusion to be removed leaving the inside flush with end cap.

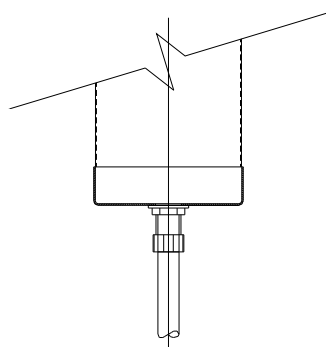

Figure 2b. Collecting Chamber Arrangement

The end cap should be sealed with silicon jointing compound and pop riveted in position. All condensate drains from the flue collecting chamber to the disposal point shall be corrosion-resistant material of not less than 22mm internal diameter. Copper or copper based alloy shall not be used for condensation drains. See reference BS 6896. Condensate drain pipes must be protected against the effects of freezing.

The Type '0' and Type '2' vacuum fans have bottom horizontal discharge with rectangular connections (flanged on the type 0) and must be mounted in that position by means of the fan support stool onto a suitable platform or brackets fixed to the building structure.

For details of the fan outlet fixing holes see below.

Figure 2c. Type 'O' Fan Outlet Dimensions

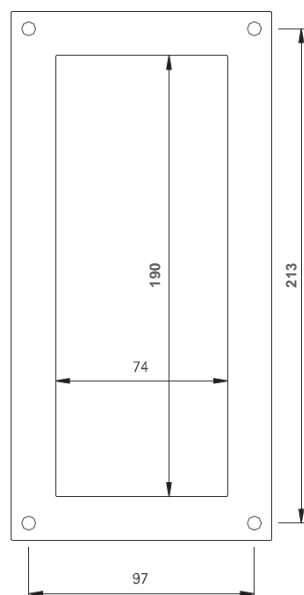

**Figure 2d.
Type 2 Fan
Outlet Dimensions**

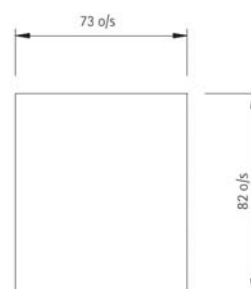

For details of fan mounting bracket and fixing down holes see figure 3.

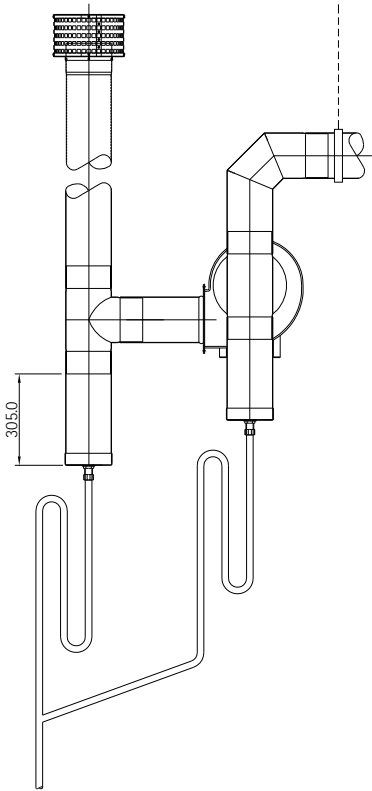

Figure 2e. Conventional Flue Arrangement Roof Exit.

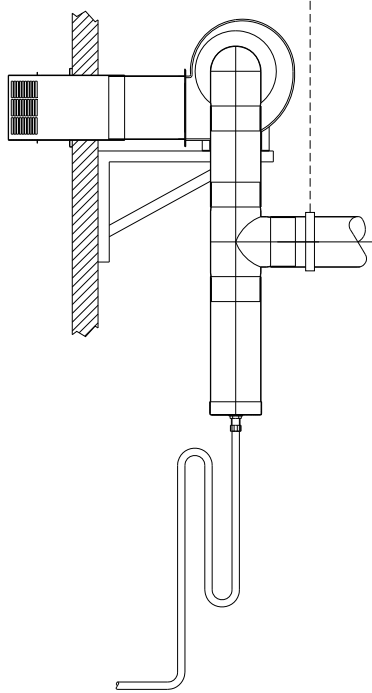

Figure 2g. Stainless Steel Telescopic Through The Wall Arrangement (available for Type 'O' and Type '2' fans)

Where a conventional flue is to be installed, AmbiRad supply an aluminium transformation piece to which a 150mm (6ins) diameter flue must be attached.

The length of flue which may be connected to the fan outlet must be adequately supported from the building structure.

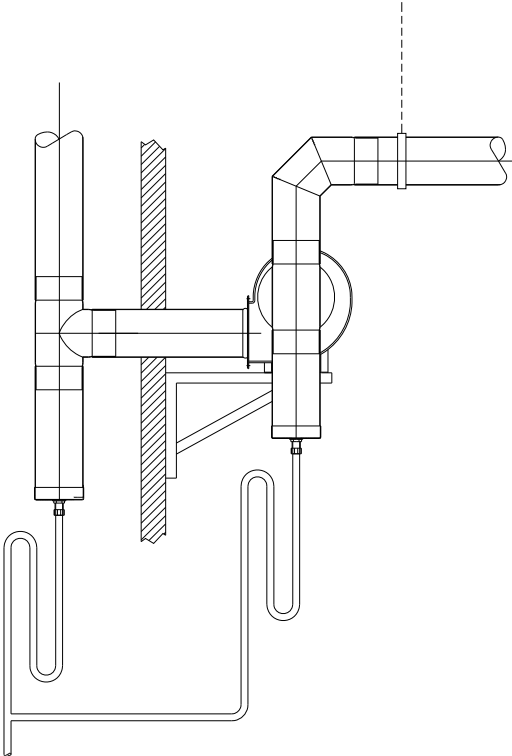

Figure 2f. Conventional Flue Arrangement Wall Exit.

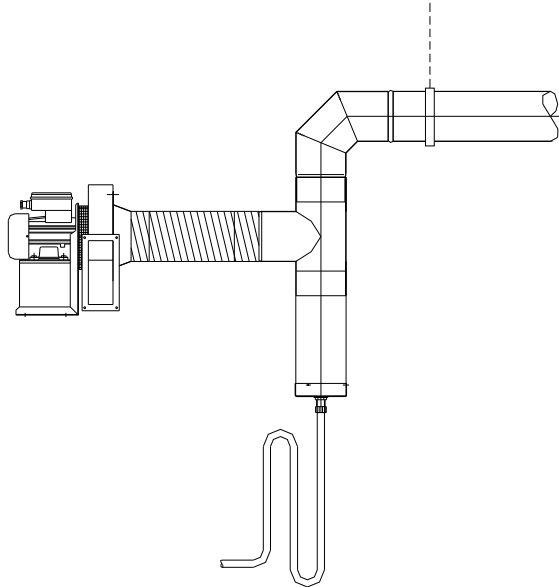
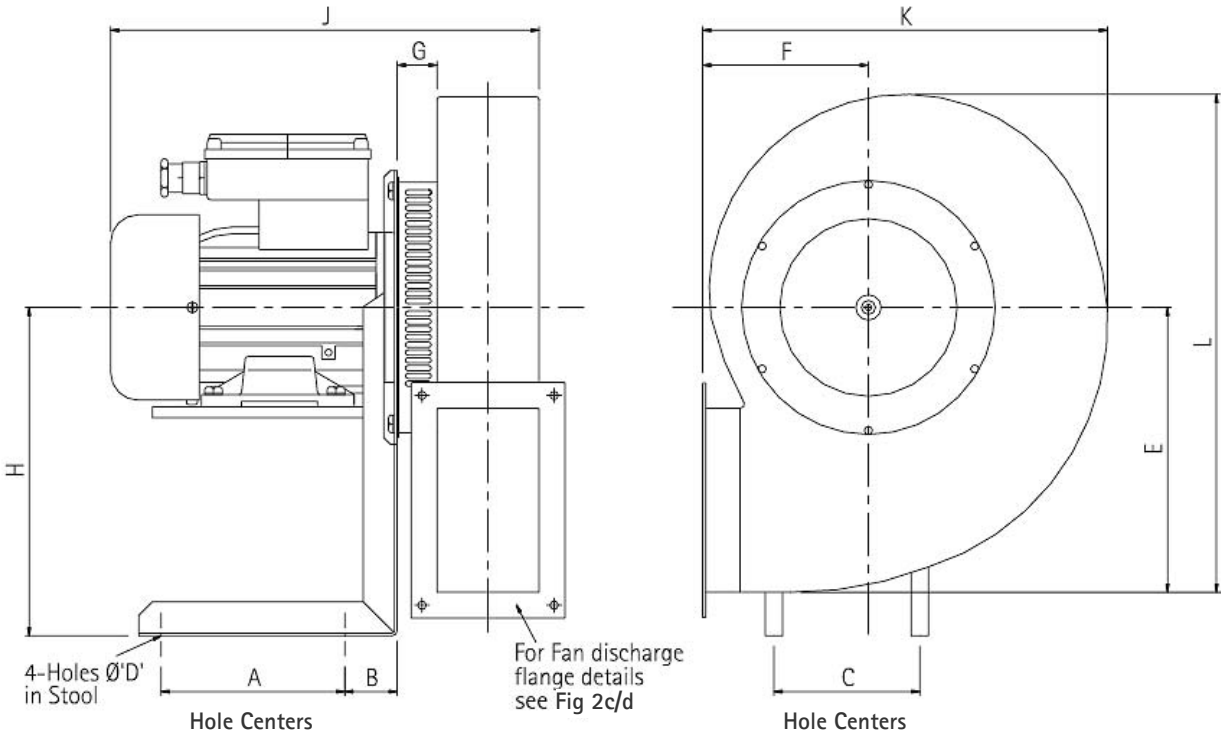

Figure 2h. Typical Low Fan Arrangement

Figure 3. Vacuum Fan Mounting Details (Type 'O' fan illustrated)



Fan	Type O	Type 2
A	124	80
B	38	35
C	175	174
D	7.1	7
E	209	125
F	153	100
G	42	25
H	239	120
J	340	210
K	332	205
L	363	215
Power (watts)	550	120
Running Current (amps)	2.6	0.8
Starting Current (amps)	15.4	4.0
Voltage	230V 1ph	230V 1ph

Figure 4. Typical Herringbone system (VSO shown with optional end covers)

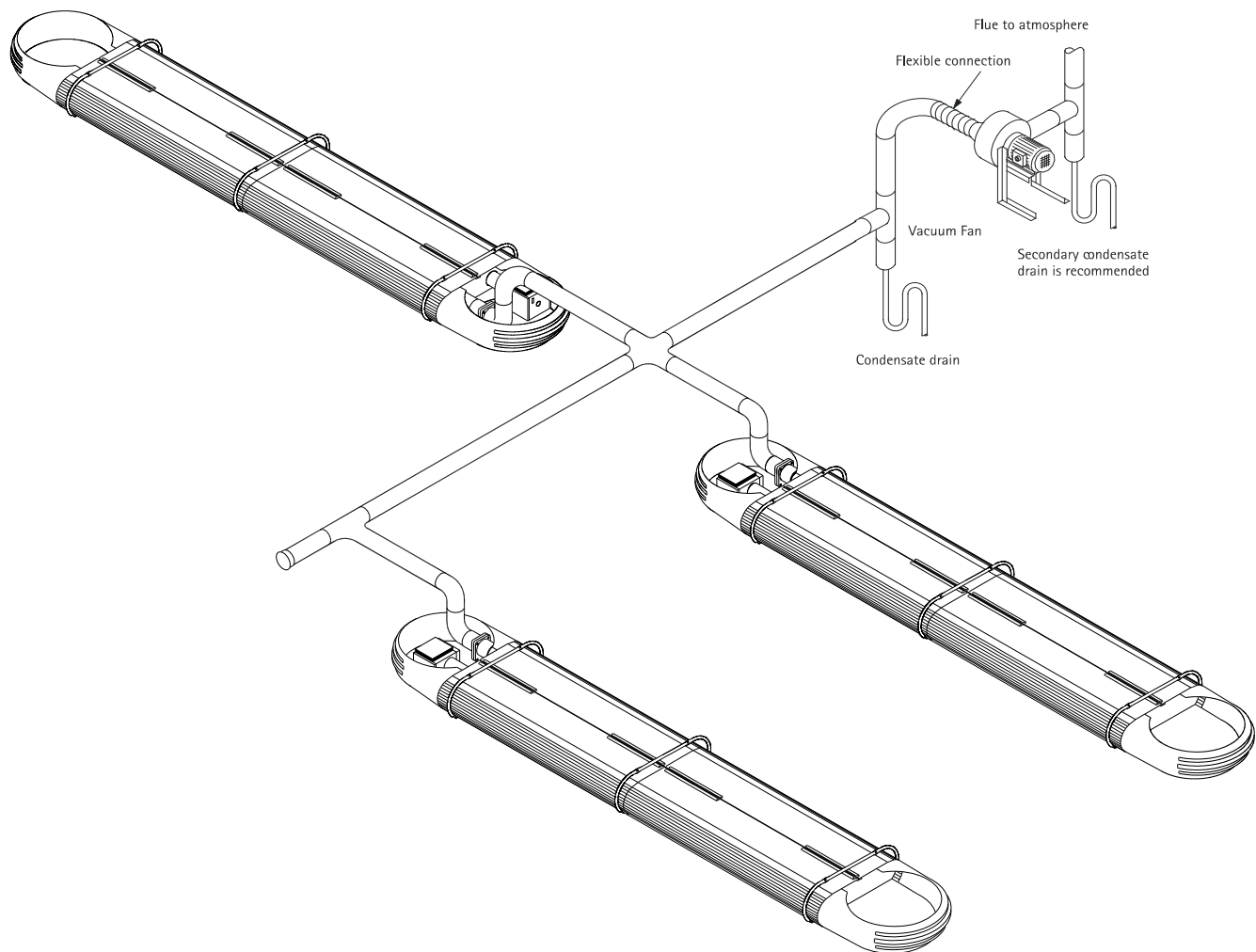

Dos and don'ts of herringbone system

Dos	Don'ts
Check design pressure drop.	Run drains in copper or mild steel pipework.
Check for corrosive industrial process in proposed building - e.g. cleaning, electroplating, printers using sugar powder etc.	Install system with extra 90° bends without asking AmbiRad if the system will operate correctly.
Drain all flue ducts and seal all joints.	Install flue with vertical rise without firstly fitting a drain point at it's lowest level.
Secure joints with pop rivets as well as sealing compound (refer to assembly instructions).	Fit fan with outlet vertical or with top horizontal discharge.
Fit drain traps before and after fans (see figs 2).	Fit damper upside down or on it's side.
Fit expansion joints before fan and at intermediate points on the herringbone system.	Fit damper wrong way round. (see fig18)
Run drains in galvanised steel or plastic pipes.	
Follow guide to combined flue heating system.	

1.6 Clearance to Combustibles.

 The minimum clearances to combustible materials are given in the tables below. These minimum distances **MUST** be adhered to at all times.

Figure 5.a Diagram illustrating the clearance to combustibles (VSXO shown c/w End Covers)



VSXO		20/25	30/35/40	45/50
Above Canopy	A	100	100	100
Above Burner / Flued Heat Exchanger	B	500	500	500
Above Burner / Heater Outlet Unflued	B1	700	700	700
To the Sides	C	915	1200	1525
Below Tubes	D	2330	2330	2330
From Heater Outlet (UNFLUED)	E	570	940	940
End Wall	F	390	470	575

Figure 5.b Clearance to combustibles Vision Optima Unitary VSO UT

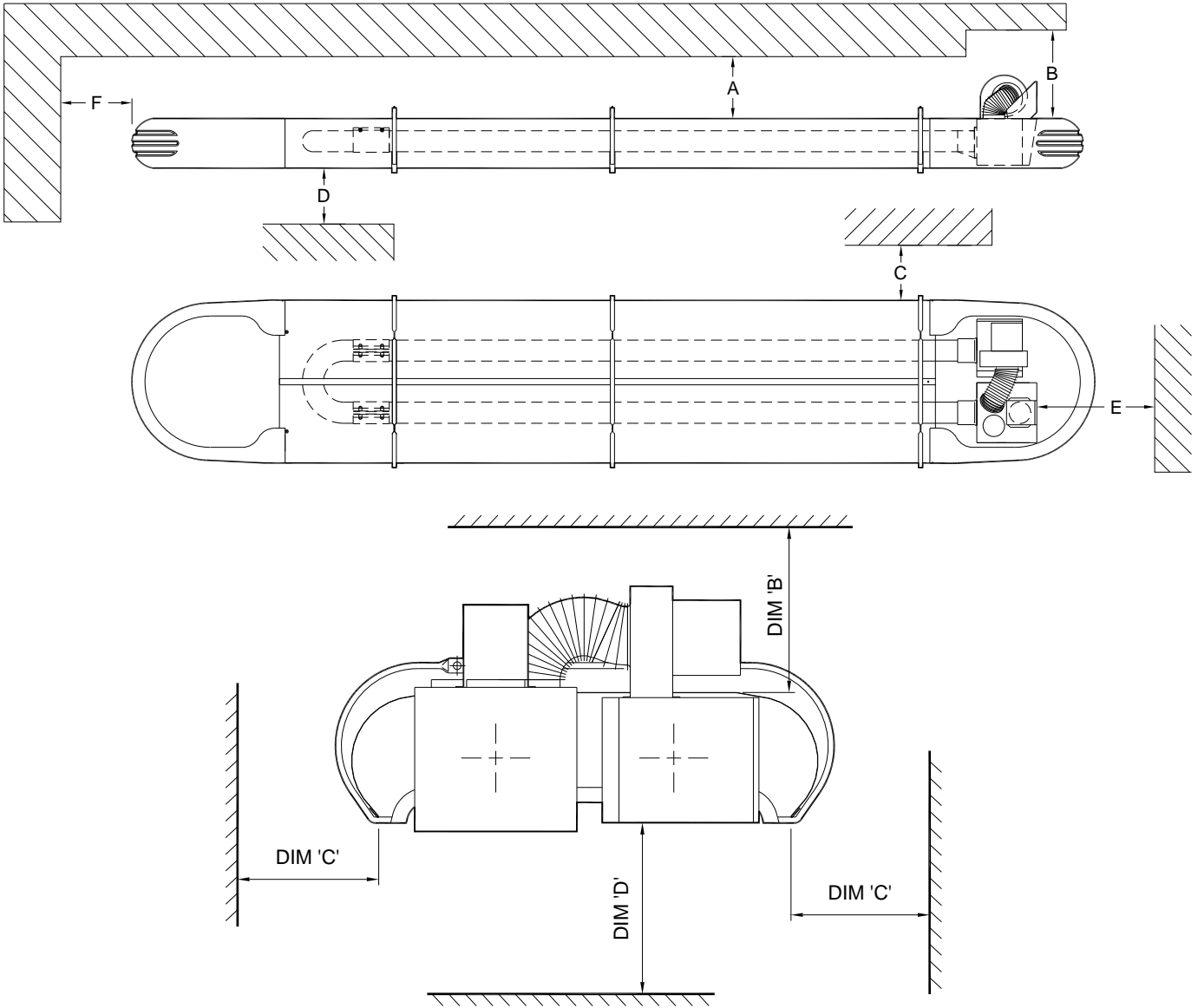
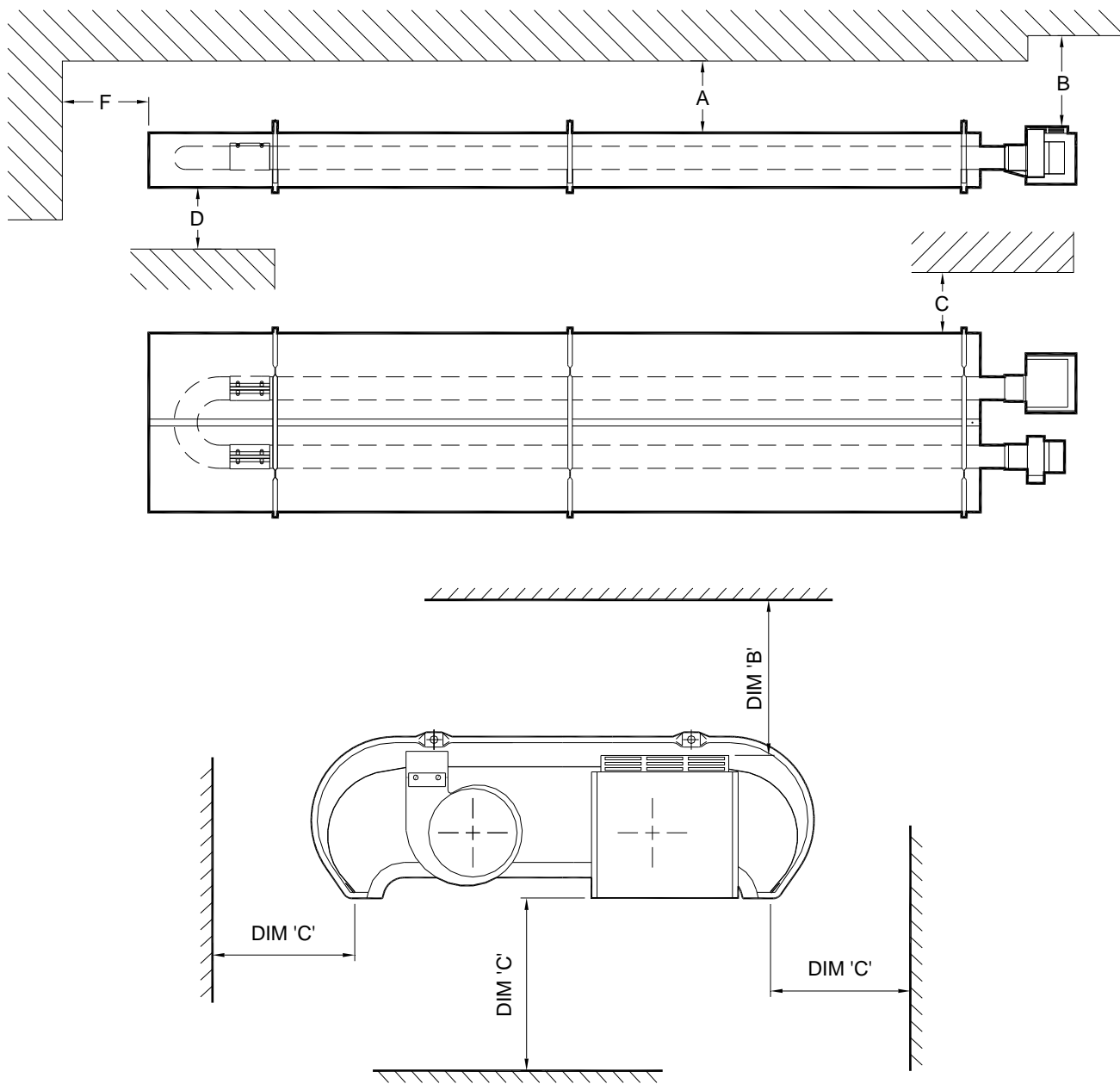

VSO UT		15/20/25	30/35/40	45/50
Above Canopy	A	100	100	100
Above Burner / Flued Heat Exchanger	B	500	500	500
Above Burner / Heater Outlet Unflued	B1	700	700	700
To the Sides	C	915	1200	1525
Below Tubes	D	2330	2330	2330
From Heater Outlet (UNFLUED)	E	570	940	940
End Wall	F	390	470	575

Figure 5.c Clearance to combustibles Vision Optima Herringbone VSO UH

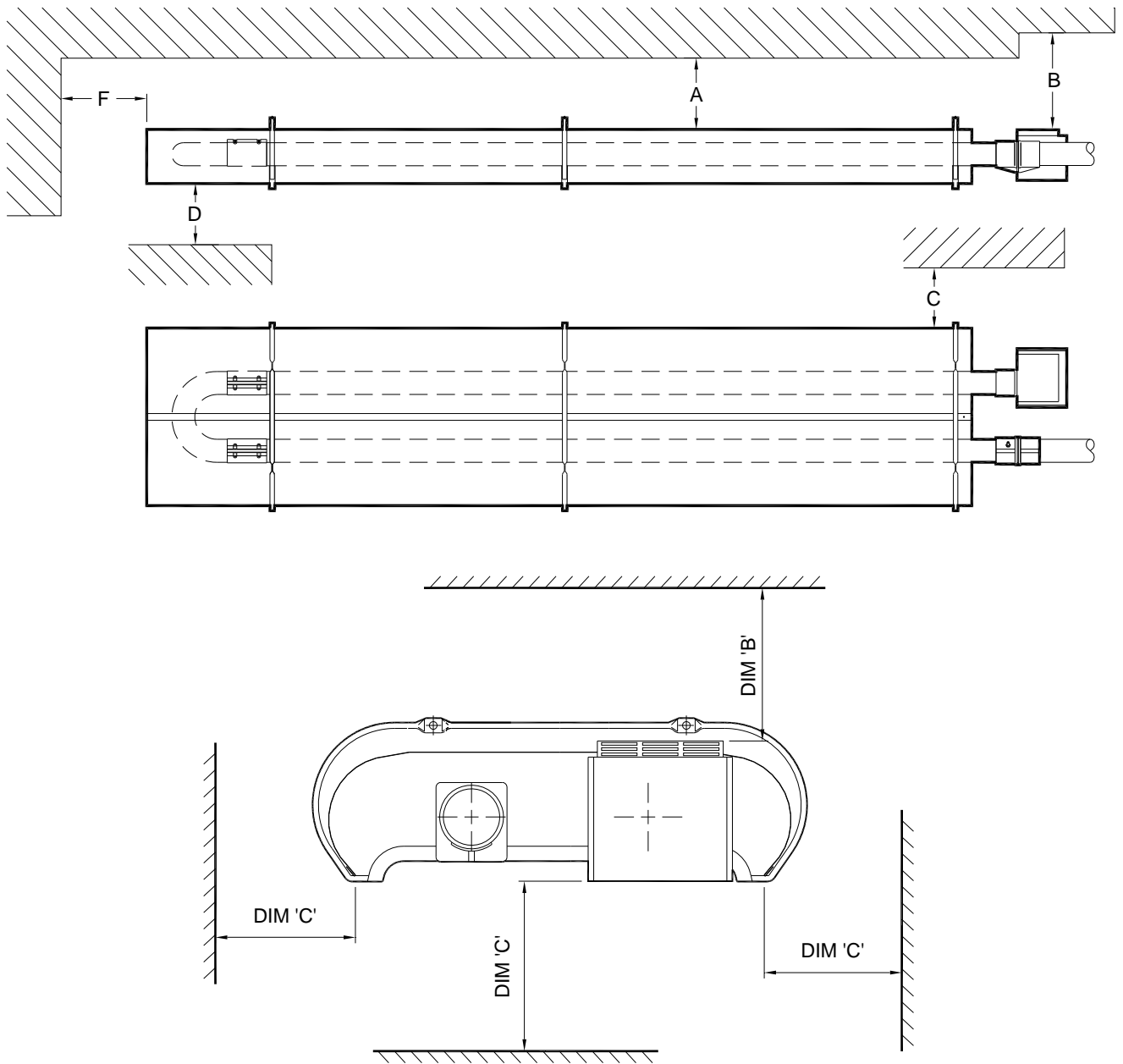

VSO UH Herringbone		15/20/25	30/35/40	45/50
Above Canopy	A	100	100	100
Above Burner / Flued Heat Exchanger	B	500	500	500
Above Burner / Heater Outlet Unflued	B1	700	700	700
To the Sides	C	915	1200	1525
Below Tubes	D	2330	2330	2330
From Heater Outlet (UNFLUED)	E	570	940	940
End Wall	F	390	470	575

1.7 Gas Connection and Supply

! Before installation, check that the local distribution conditions, nature of gas and pressure, and adjustment of the appliance are compatible.

A competent or qualified engineer is required to either install a new gas meter to the service pipe or to check that the existing meter is adequate to deal with the rate of gas supply required. Installation pipes should be fitted in accordance with BS 6896, so that the supply pressure, as stated in Table 4 will be achieved. It is the responsibility of the competent engineer to ensure that other relevant Standards and Codes of Practice are complied with in the country of installation. Pipes of smaller size than the heater inlet gas connection must not be used. The complete installation must be tested for soundness as described in the country of installation.

! The gas union service cock MUST be fitted in the gas supply close to the heater, but not onto the burner itself.

i Take care when making a gas connection

to the heater not to apply excessive turning force to the internal controls.

A flexible hose is installed to allow safe linear expansion of the heater without creating undue stress on the gas supply pipe work. It is therefore important that a tested and certified hose assembly made to ISO 10380, supplied with 1/2" BSP female cone seat adapters, is installed as per these instructions.

It is also important to ensure that expansion is taken up in the body of the flexible hose, and not on its attachment to the pipe work. The cone seat adapter supplied on one end of the flexible gas hose provides a 'swivel' action, and must be fitted on the burner using a 1/2" BSP barrel nipple to provide ease of disconnection for future servicing. This assumes that the heater and fixed gas supply to the isolating valve have been installed.

i The installation layout described below is the only method recommended by the institute of gas engineers, the hose manufacturer, and AmbiRad and must only be carried out by a qualified/competent gas engineer.

Figure 6. Correct Installation of Flexible Gas Connection

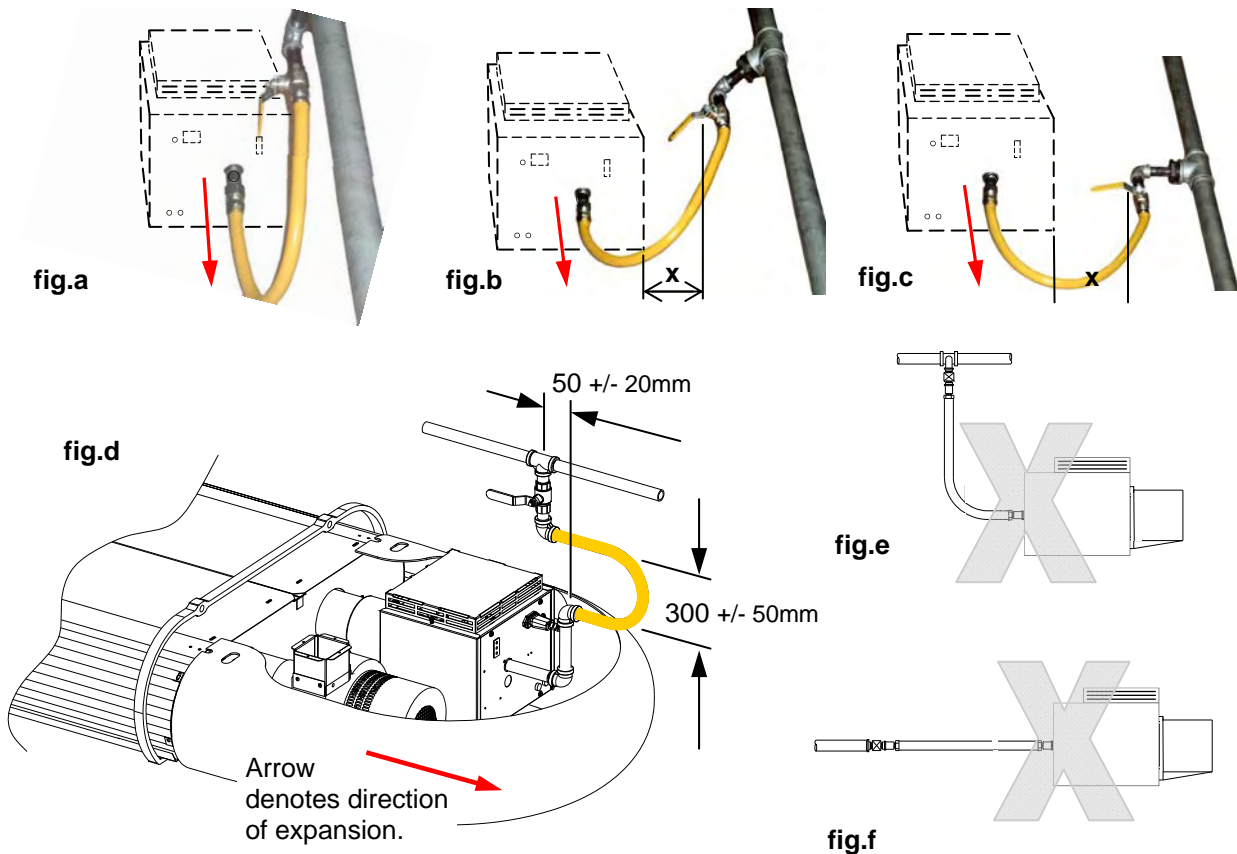

The methods shown in fig.e and fig.f are unacceptable, due to undue stress on the hose & fittings.

Depending on the specific installation, the flexible gas hose may be routed to the gas cock at any of the following angles in relation to the burner:

- Vertical (fig.a)
- 45° angle (fig.b)
- 90° angle (fig.c)

Any other position in between these angles is acceptable.

 A clearance distance 'x' of min 200mm must be observed to allow side door access .

Care must be taken to observe the minimum pipe bend diameter (minimum 250mm, maximum 350mm) & pipe expansion distance (minimum 30mm, maximum 70mm) as shown in fig.d.

 Maximum bend diameter for the 1000mm hose is 450mm.

 The correct installation as shown will allow for approx 100mm of movement due to expansion.

Table 4 Gas Supply Pressures

Gas Category	I2H	I3P
Gas Type	Natural Gas (G20)	Propane (G31)
Max Supply Pressure (mbar)	25	45
Min Supply Pressure (mbar)	17	25
Nominal Pressure (mbar)	20	37
Gas Supply	Connection R½ ½in BSP Internal Thread	

1.8 Electrical Connection

This appliance must be earthed.

Supply 230V 50Hz single phase.

Standard heater 116W.

Current rating 0.55 amp max (inductive).

Fuse: external 3 amp.

All electrical work should be carried out to IEE standards by a competent electrician. The electrical connection to the heater is made by means of a three pin plug-in power connector.

Live, neutral and earth connections should be made via a flexible supply cable to the power connector and routed clear of the heater or tubes.

The flexible supply cables should be of 0.5mm² and comply with BS 6500. The wires in the mains lead are coloured in accordance with the following code:

- Green & Yellow Earth;
- Blue Neutral;
- Brown Live

It is recommended the heater or group of heaters are controlled by thermostats, a time switch and if required manual control switches and a frost thermostat.

 We recommend use of AmbiRad approved controls. Please refer to control manual for siting and installation details.

Where alternative manufactures controls are used, please refer to their instructions for their siting and installation details.

Figure 7.a Single Phase Wiring

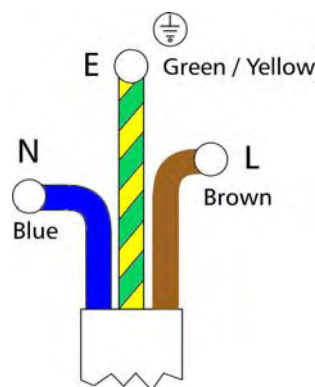

Figure 7.b Typical VSOUT Induced Unitary Wiring Connections (end covers not shown)

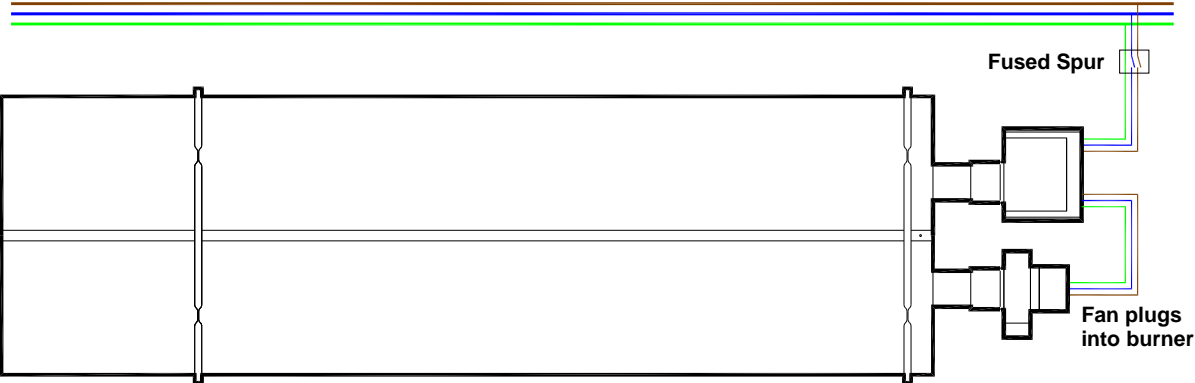

Figure 7.c Typical VSOUH Herringbone Wiring Connections (end covers not shown)

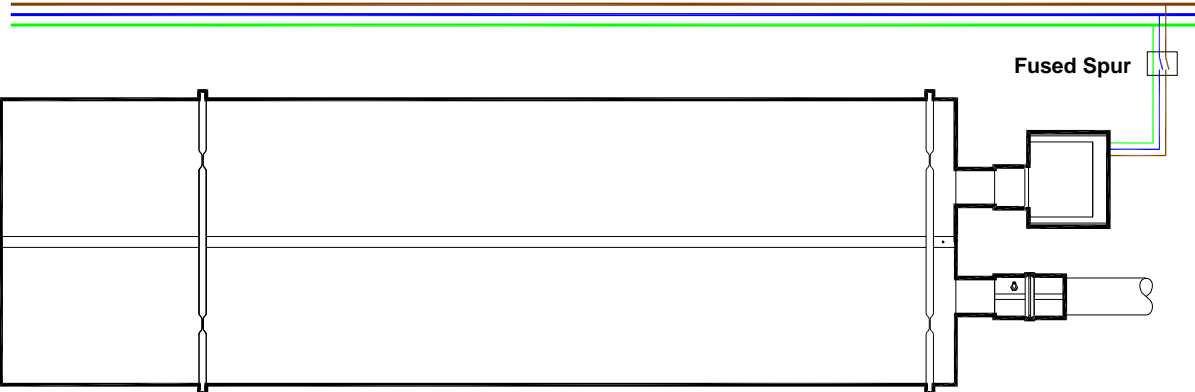

Figure 7.d Typical VSXO Powered Burner Unitary Wiring Connections (end covers not shown)

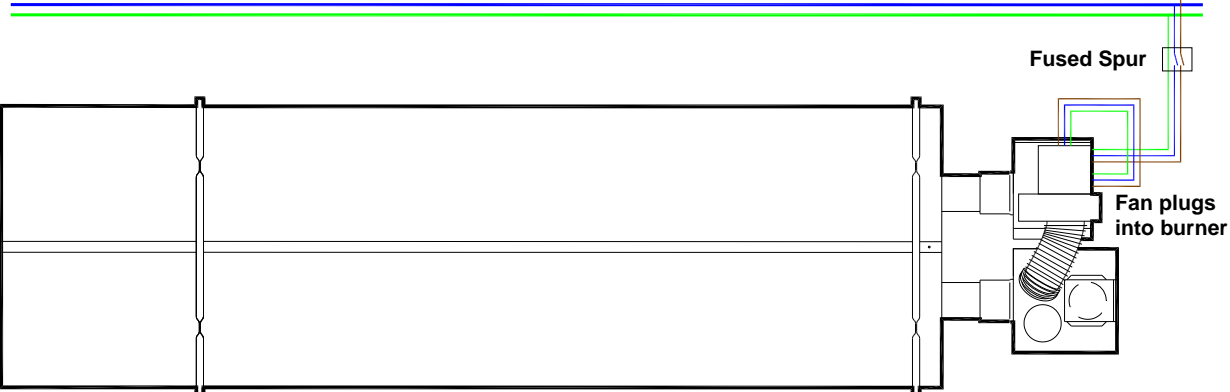

Figure 7.e Typical VSXO Powered burner Wiring Connections (end covers shown)

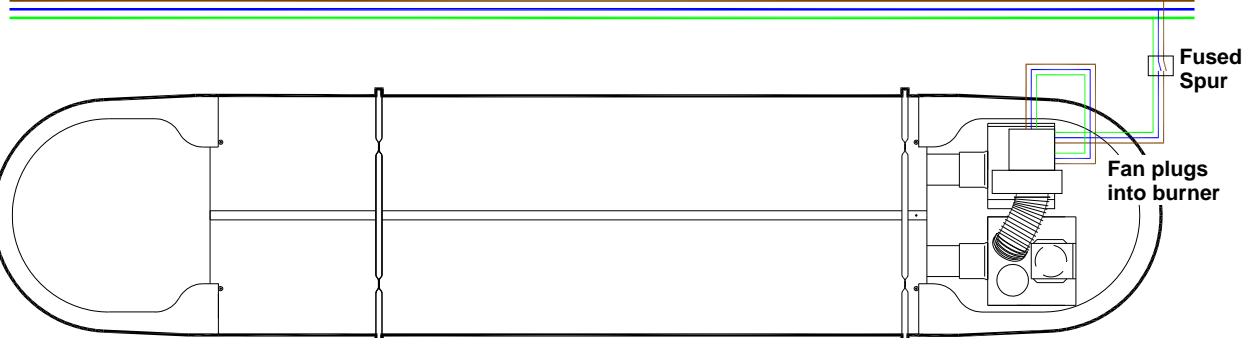

Figure 8. Internal Burner Wiring Diagram.

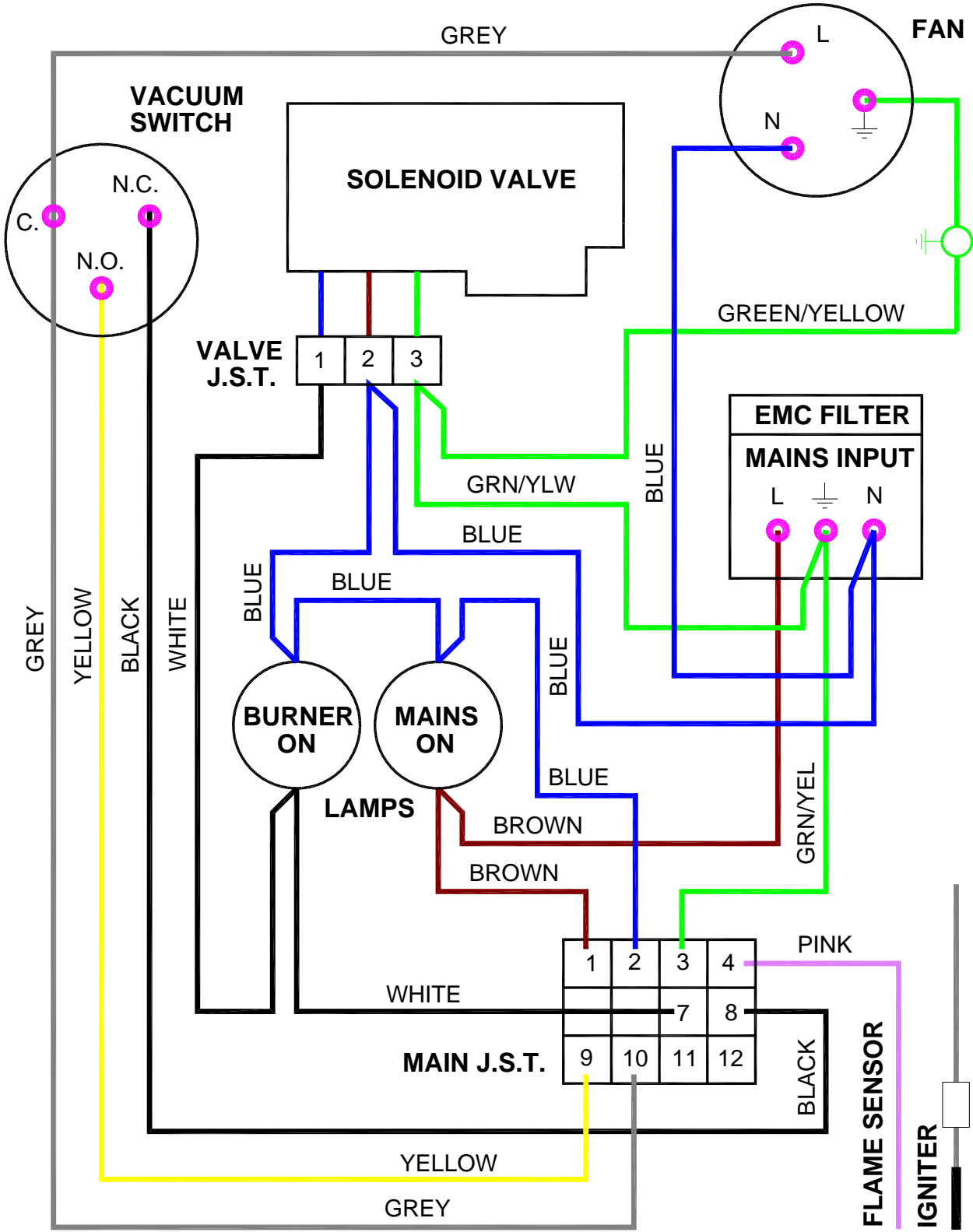
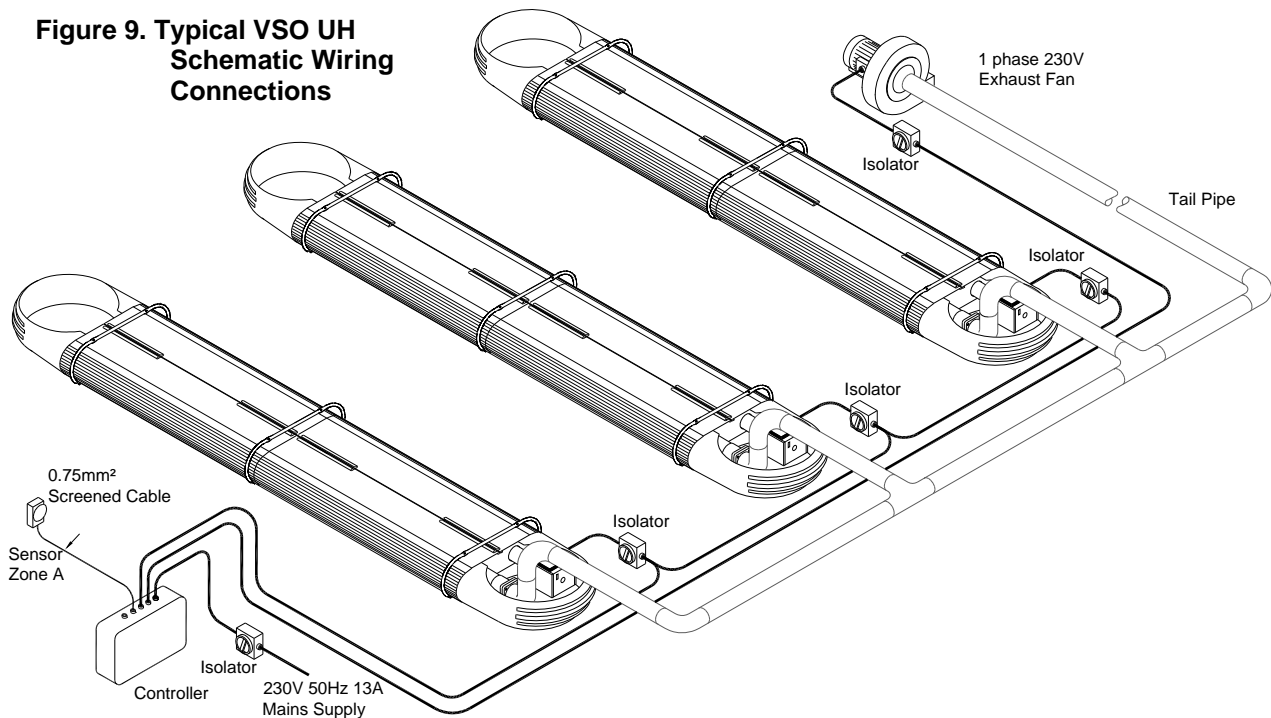

Figure 9. Typical VSO UH Schematic Wiring Connections



1.9 Ventilation Requirements

AmbiRad tube heaters can be operated as flued or unflued appliances in accordance with the relevant national requirements in the country of installation.

1.9.1 Unflued Radiant Heater

Radiant tube heaters can be operated as unflued appliances so that the concentration of Carbon Dioxide (CO₂) at positions where the air will be inhaled does not exceed 0.28%. BS EN 13410 is a guide to achieving this requirement.

If the building air change rate exceeds 1.5 per hour or if the heat input is less than 5W/m³, no additional ventilation is required.

In addition to the ventilation requirements, consideration needs to be given to the possibility of condensation forming on cold surfaces.

It should be noted that the clearance distance around the burner increases when the unit is operated unflued (see section 1.6). It should be ensured that the combustion gases do not impinge on any combustible materials.

Mechanical Ventilation

Mechanical ventilation must be rated at minimum 10m³/h per kW input using appropriately sized fans and interlocked with heaters.

Natural Ventilation

BS EN 13410 should be used to size air vents to provide adequate ventilation, an example of this calculation is given below:

Site Details:

20°C Internal Operating Temperature

0°C Outside Air Temperature

5m between high and low level vents

Following the sizing procedure in BS EN 13410 gives an air exit velocity of 1.6m/s. This equates to a free area vent at both high level and low level of 17.36cm²/kW free area.

1.9.2 Flued Radiant Heater

In buildings having an air change rate of less than 0.5 per hour, additional mechanical or natural ventilation is required. For detailed information, please see BS6896 section 5.2.2.2.1

Mechanical Ventilation

Mechanical ventilation must be installed to meet a minimum of 0.5 air changes per hour using appropriately sized fans and interlocked with the heaters.

Natural Ventilation

Low level ventilation openings with a free area of at least 2cm²/kW shall be provided. See section 5.2.2.2.1.

1.10 Flue and Combustion Air Inlet - Options

Dependent on the type of burner fitted to your heater it is possible to have configurations of flue and combustion air inlet options to those shown overleaf:

- **Option 1**

For induced burner with / without flue and / or optional ducted air inlet refer to Figure 10.a

- **Option 2**

For herringbone heaters refer to Figure 10.b & section 1.5 Herringbone Systems (UH/LH).

- **Option 3**

For forced burner with / without flue and ducted air inlet refer to 10.c

- **Option 4**

For ducted air and products of combustion to ventilated area please refer to Figure 10.c. & 10.d.

- **Option 5**

For flued products of combustion and ducted air via concentric pipe please refer to Figure 10.e.

1.10.1 Important Information

1.10.1.1 Option 1 and 3

A suitable flue system complying with EN1856-1 (type T250 N1 D Vm L11040 O50) should be used.

Flue size 125mm diameter twin wall.

Flue systems can run either vertically or horizontally up to a **maximum length of 9.5m** (including up to 2 x 90° bends plus the terminal).

The minimum flue length shall be 1m.

The flue system **must be terminated in a vertical position** and in accordance with the British Standard Code of Practice BS 5440: Part 1 - Installation and maintenance of flues and ventilation for gas appliances of rated input not exceeding 70kW net (1st, 2nd and 3rd family gases), and the flue system manufacturers instructions as supplied with the flue.

1.10.1.2 Option 2

The tailpipe as supplied by the manufacturer is to be used and installed as per the manufacturers design drawing.

A suitable flue system complying with EN1856-1 (type T250 N1 D Vm L11040 O50) may be used as an alternative to that offered by the manufacturer.

Flue systems can run either vertically or horizontally up to a **maximum length of 9.0m** (including up to 2 x 90° bends plus the terminal).

The minimum flue length shall be 1m.

The flue system **may be terminated vertically or horizontally** but in accordance with the British Standard Code of Practice BS 5440: Part 1 - Installation and maintenance of flues and ventilation for gas appliances of rated input not exceeding 70kW net (1st, 2nd and 3rd family gases), and the flue system manufacturers instructions as supplied with the flue.

1.10.1.3 Option 5

A suitable flue system complying with EN1865-1 (type T200 P1 W V2 L50050 O00) should be used.

Flue size 100mm diameter single wall.

The **maximum flue length** shall be 9.0m (including up to 2 x 90° bends plus the terminal).

The minimum flue length shall be 1m.

The flue system **must be terminated vertically only** and in accordance with the British Standard Code of Practice BS 5440: Part 1 - Installation and maintenance of flues and ventilation for gas appliances of rated input not exceeding 70kW net (1st, 2nd and 3rd family gases), and the flue system manufacturers instructions as supplied with the flue.

1.10.2 Installation

Connection to an appliance which is not connected to the fuel supply may be carried out by a competent person. However, connection to an appliance that is connected to the fuel supply **must** be carried out by a registered installer.

If the flue passes through a wall, ceiling, or roof made from combustible material then it has to be sleeved so as to provide a minimum of a 50mm void between the exterior of the flue and the internal wall of the sleeve. A minimum of 50mm must be maintained as a clearance distance to all other combustible materials.

The manifold should be supported by chain, stainless steel flexible wire, or other flexible means from the roof structure to allow movement caused by thermal expansion.

The maximum distance between supports is 1.5m for horizontal runs.

Wall bands are not load bearing and give lateral support only. If used, wall bands should be fitted every 3m on vertical runs to ensure the system is rigidly held. The system should be braced immediately below passing through the roof line to ensure the flashing does not suffer lateral pressures.

The maximum height unsupported above the roof line is 1.5m. Where a joint is above the roofline it should be determined that in extreme wind conditions this joint would not be over exerted. If there is any doubt then a guy wire should be used. Beyond this guy wires should be installed every meter.

The POCED is capable of withstanding its own weight when installed in accordance with these instructions and the Regulations shown below.

The exhaust flue should be adequately supported from the building structure and installed in accordance with the British Standard Code of Practice BS 5440: Part 1 – Installation and maintenance of flues and ventilation for gas appliances of rated input not exceeding 70kW net (1st, 2nd and 3rd family gases), and the flue system manufacturers instructions as supplied with the flue. See reference BS 6896. Condensate drain pipes must be protected against the effects of freezing.

1.10.3 Condensation

When designing the flue system the prevention of the formation and entrapment of condensation must be a key consideration.

Horizontal flue should be fitted ensuring a slight gradient approx 5° towards the terminal. Where condensation is unavoidable traps should be included to encourage the condensates to flow freely to a point from which they may be released, preferably into a gully. The condensate pipe from the flue to the disposal point must be made from corrosion resistant pipe of not less than 25mm internal diameter.

1.10.4 Method of Jointing Tube

1.10.4.1 Option 1 and 3

All pipe lengths and flue gas carrying components are joined together by a twist lock, bayonet system. The system should be installed

with the visible male collar pointing upwards, this is reaffirmed by the directional arrow pointing upwards, indicating the directional flow of flue gases. Taping of the joints is unnecessary.

1.10.4.2 Option 2 Tailpipe

After allowing for a minimum of 75mm (3in) of penetration of the fitting into the tube, cut the tubes to the lengths required and remove all burrs and wipe off any grease or oil with a clean rag.

The components are joined by pushing the male spigot and female socket together until the stop is reached.

To seal use an applicator gun and apply a 4mm diameter bead of high temperature silicon jointing compound externally round the end of the male spigot and internally round the end of the female socket.

Push the male spigot into the female socket using a slight rotating movement to spread the jointing compound uniformly until a penetration of 75mm (3in) is achieved.

Note The silicon jointing compound remains workable after application for only 5 minutes

Secure the joint by drilling through the tube and fitting and fix with three pop rivets at 12 o'clock, 4 o'clock and 8 o'clock positions. 4.8mm (3/16in) diameter pop rivets are recommended.

1.10.4.3 Option 5

The components are joined by pushing the male spigot and female socket together until the stop is reached. No sealant is required, but can be applied if the formation of condensation is anticipated.

To seal use an applicator gun and apply a 4mm diameter bead of high temperature silicon jointing compound externally round the end of the male spigot and internally round the end of the female socket.

Push the male spigot into the female socket using a slight rotating movement to spread the jointing compound uniformly until both fittings have fully engaged.

Note The silicon jointing compound remains workable after application for only 5 minutes

Option 1 - Figure 10a. Air Inlet Attachments Unitary Herringbone Burners (VSO)

For non-flued installations, delete items A and B and rotate fan outlet to the HORIZONTAL position away from the burner.

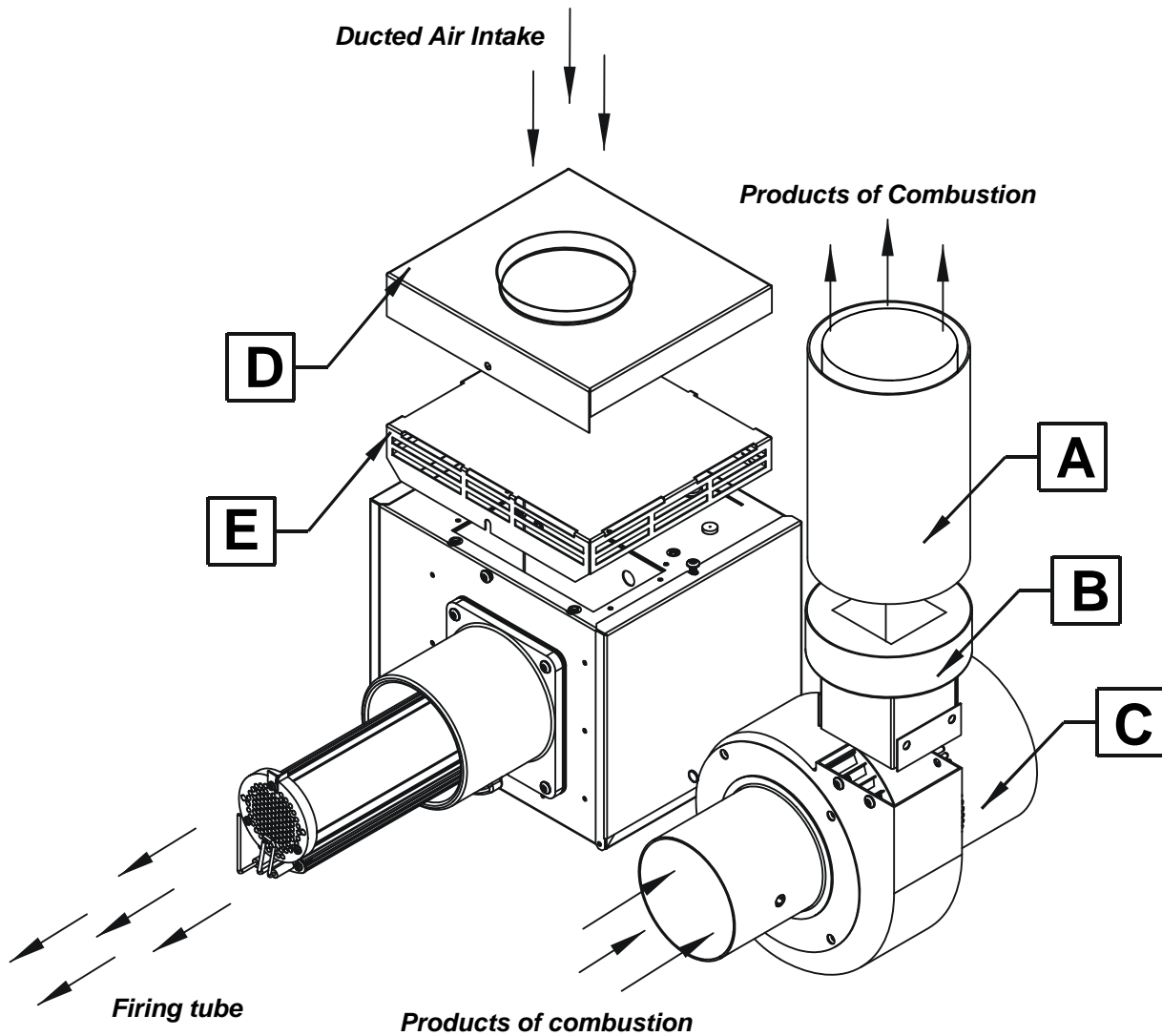

 Ventilation requirements are as detailed in section 1.9

 Ducted air must be used in locations where there is airborne dust or where there is a polluted atmosphere e.g. Chlorinated Vapours.

 Maximum length = 9m
 Minimum diameter = 100mm
 Maximum no of bends = 2

- | | |
|---|---|
| A | 127mm (5ins) Twin Wall Flue System |
| B | Fan Adaptor 7177-SUB (2501/2507 fan) or 7176-SUB (2506 fan) |
| C | Fan 2501/2507 or 2560 |
| D | Optional Ducted Air Intake. VSI-DA |
| E | Standard Air Intake (supplied as standard) |

 Maximum flue run = 9.5m @ Ø125mm
 Maximum no of bends = 2
 All flues must **terminate** vertically.
 For further information on flue runs, please refer to section 1.10.1 and BS 5440 pt.1

Option 2 - Figure 10b. Air Inlet Attachments Induced Herringbone Burners (VSO)

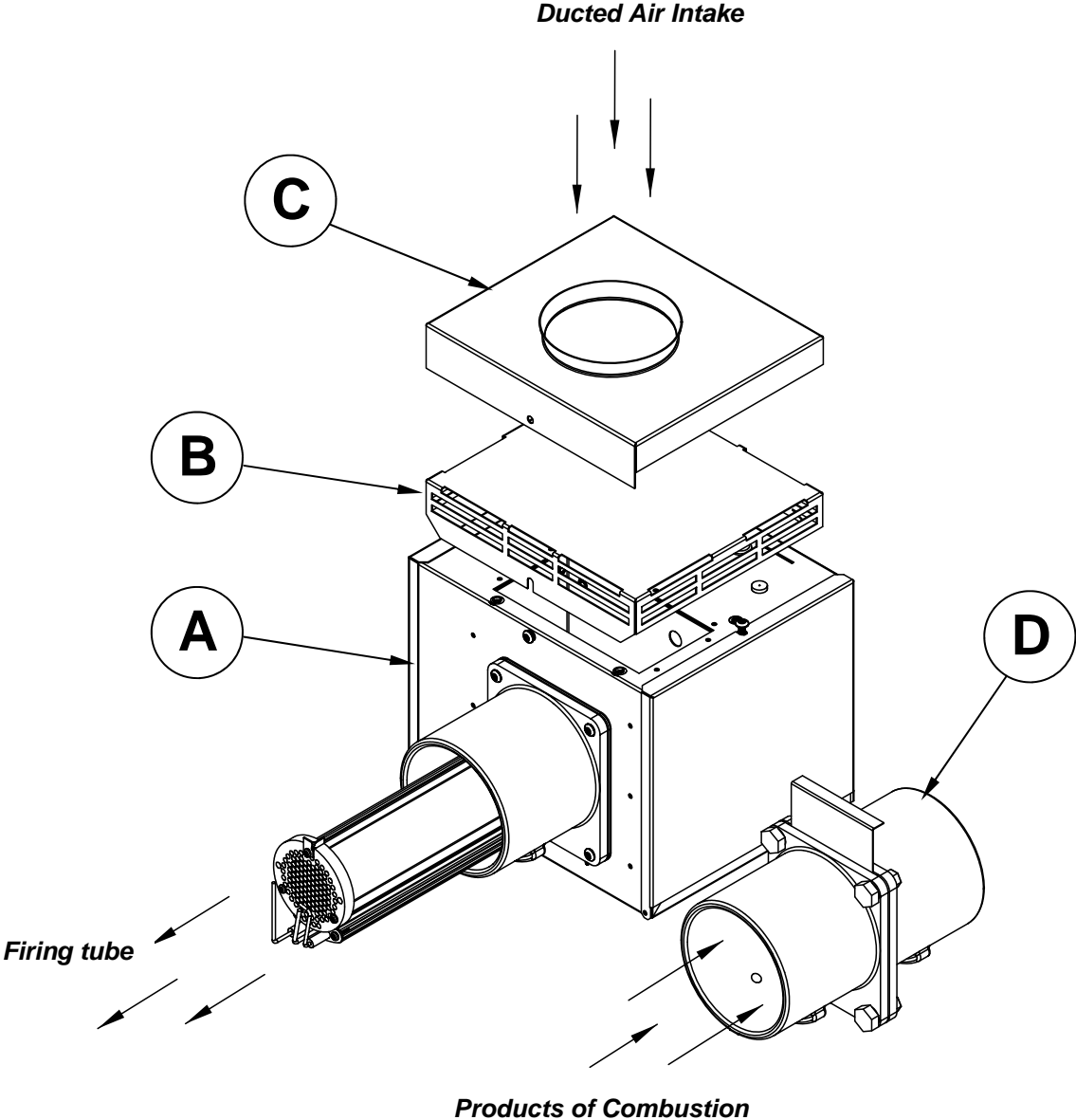

 *Ventilation requirements are as detailed in section 1.9*

 Ducted air must be used in locations where there is airborne dust or where there is a polluted atmosphere e.g. Chlorinated Vapours.

 Maximum length = 9m
 Minimum diameter = 100mm
 Maximum no of bends = 2

A	Induced Burner
B	Air Intake (supplied as standard)
C	Optional Ducted Air Intake. (see notes)
D	Damper assembly

Option 3 - Figure 10c. Forced Burner with Heat Exchanger (VSXO Standard Flue)

For flued products of combustion and no ducted air

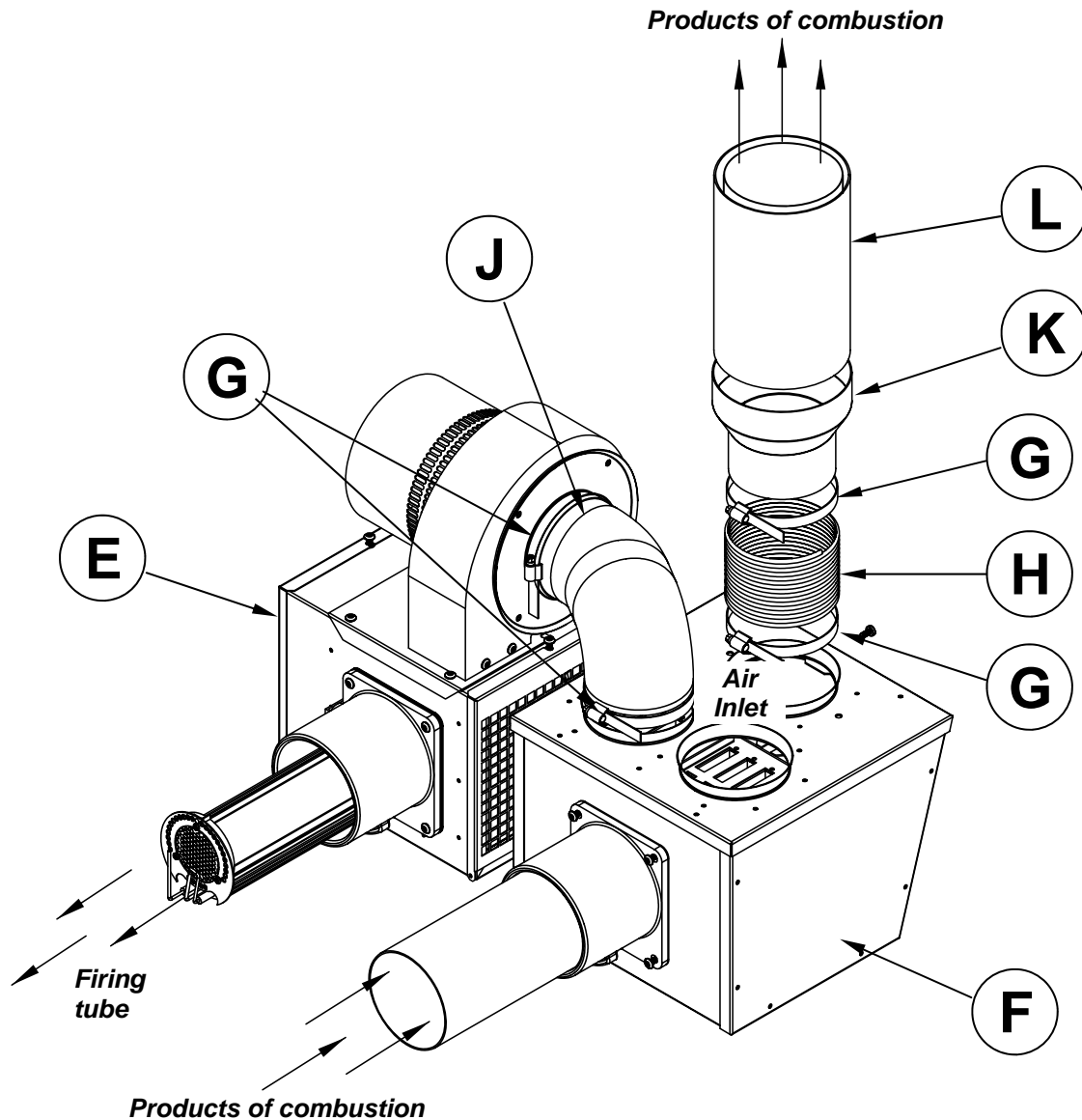

i Maximum flue length = 9.5m @ Ø125mm
 Maximum no of bends = 2
 All flues must **terminate** vertically.
 For further information on flue runs, please refer to section 1.10.1 and BS 5440 pt.1

! Ducted air must be used in locations where there is airborne dust or where there is a polluted atmosphere e.g. Chlorinated Vapours.

i Maximum length = 9m
 Minimum diameter = 100mm
 Maximum no of bends = 2

E	Forced Burner
F	Heat Exchanger
G	100mm (4ins) Clips x2
H	100mm (4ins) Flexible Flue
J	100mm (4ins) Flexible Flue to Fan
K	127mm (5ins) to 100mm (4ins) Reducer
L	127mm (5ins) Twin Wall Flue Pipe

! Ventilation requirements are as detailed in section 1.9

Option 4 - Figure 10d. Forced Burner with Heat Exchanger (VSXO No External Flue)

For ducted air and products of combustion to ventilated area

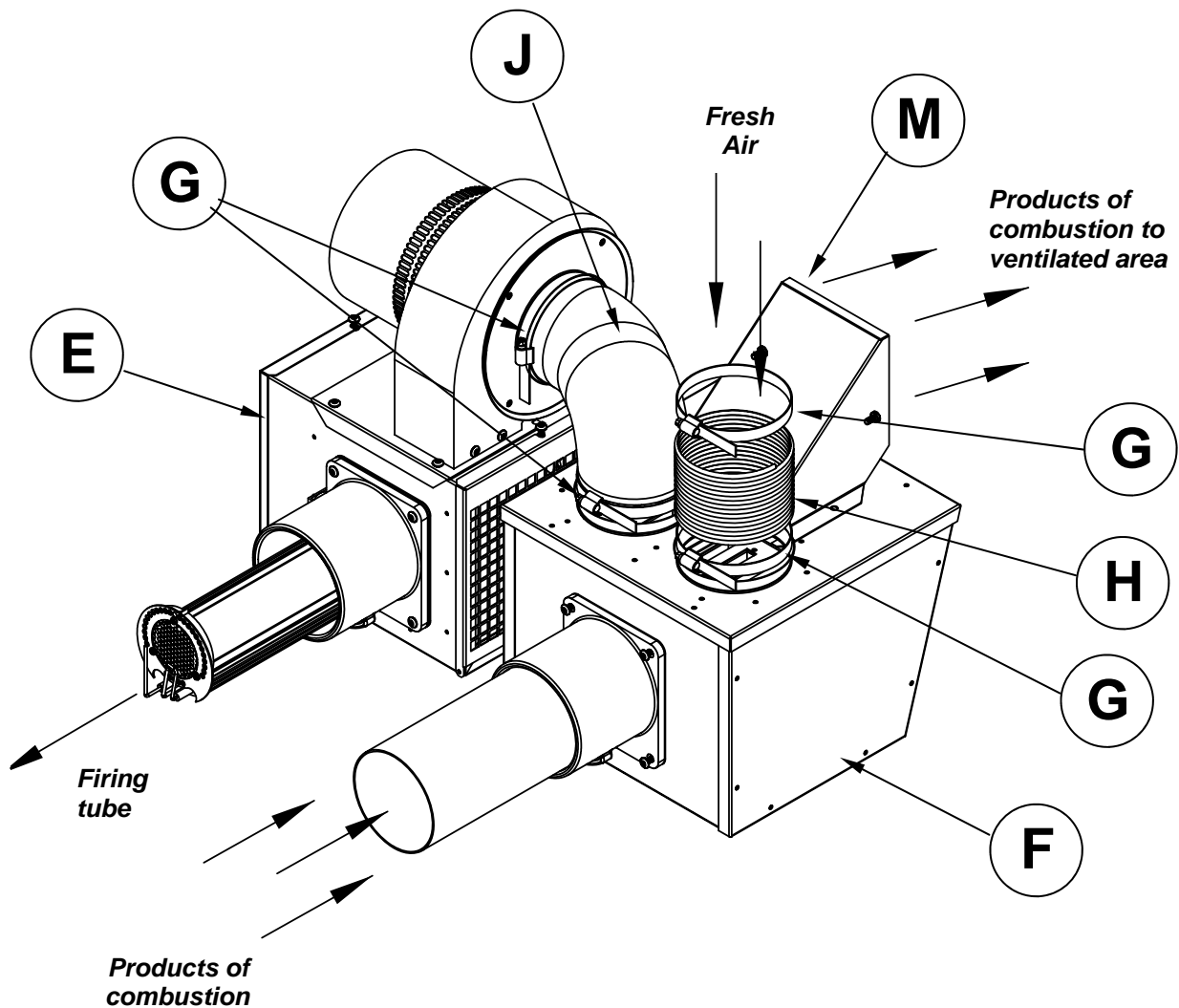

 Ventilation requirements are as detailed in section 1.9

 Ducted air must be used in locations where there is airborne dust or where there is a polluted atmosphere e.g. Chlorinated Vapours.

 Maximum length = 9m
 Minimum diameter = 100mm
 Maximum no of bends = 2

E	Forced Burner
F	Heat Exchanger
G	100mm (4ins) Clips x2
H	100mm (4ins) Flexible Flue
J	100mm (4ins) Flexible Flue to Fan
M	Shroud for unflued heater installation (supplied as standard)

Option 5 - Figure 10e. Forced Burner with Heat Exchanger (with Concentric Flue)

For flued products of combustion and ducted air via concentric pipe.

IMPORTANT NOTE
 This option is a type B₂₃ flue system with ducted air and is not a room sealed balanced flue product.

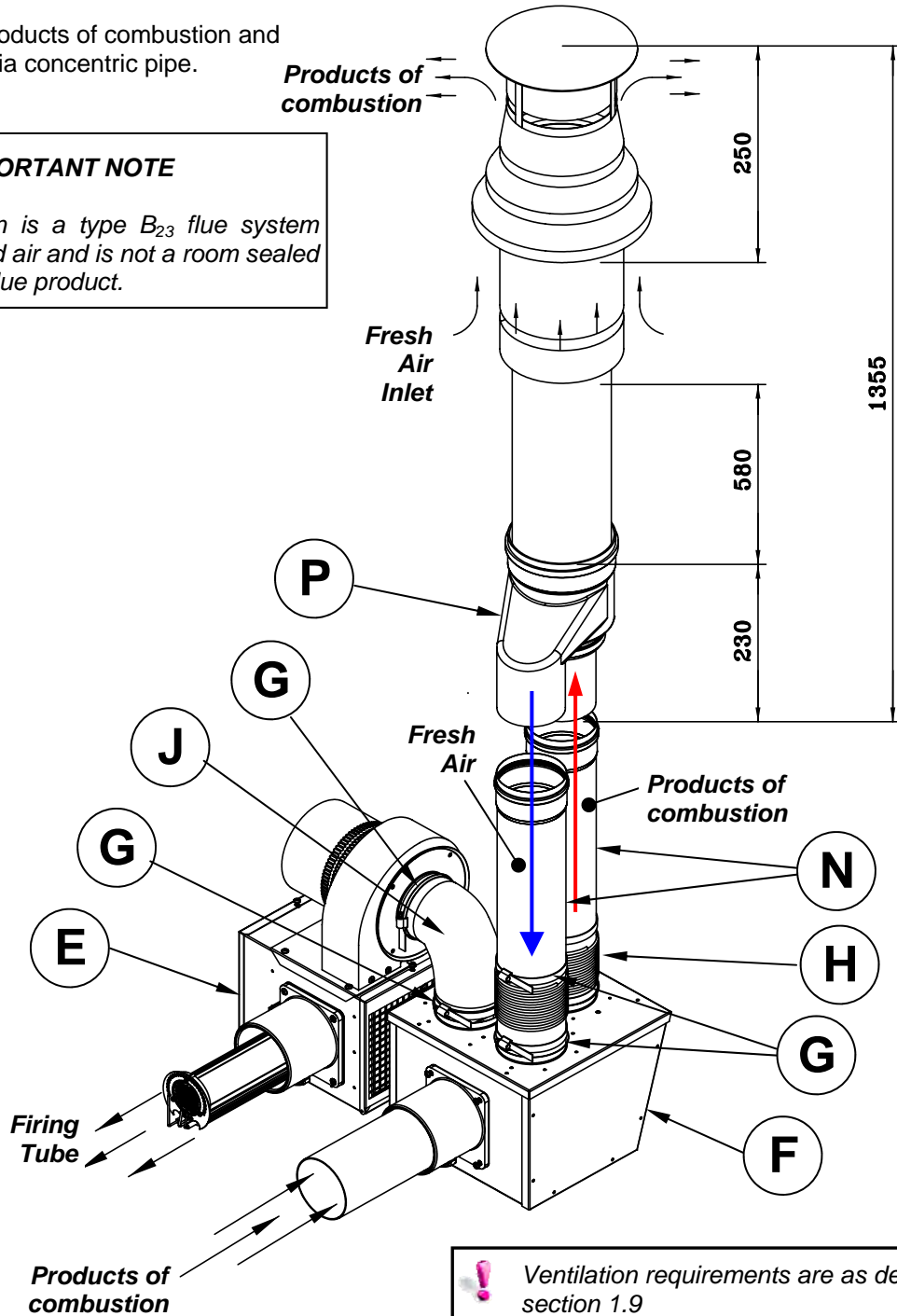

E	Forced Burner
F	Heat Exchanger
G	100mm (4ins) Clips x2
H	100mm (4ins) Flexible Flue
J	100mm (4ins) Flexible Flue to Fan
N	Flue Extension optional (0.25m/0.5m/1.0m)
P	Concentric Flue Terminal

! Ventilation requirements are as detailed in section 1.9

i Maximum flue length = 9.0m @ Ø125mm
 Maximum no of bends = 2
 All flues must **terminate** vertically.
 For further information on flue runs, please refer to section 1.10.1 and BS 5440 pt.1

! Ducted air must be used in locations where there is airborne dust or where there is a polluted atmosphere e.g. Chlorinated Vapours.
 Maximum length = 9m
i Minimum diameter = 100mm
 Maximum no of bends = 2

1.11 Technical Details.

No of Injectors	1
Gas Connection	½ in BSP Internal thread
Flue Nominal Bore mm (in)	125 (5)
Unitary Fan Motor Details	230 volt 1 phase 50Hz

Table 5. Burner Settings - Natural Gas (G20)

Heater Model	Heat Input kW		Gas Flowrate (m³/hr)	Injector Pressure (mbar)	Injector Size (mm)	*Size (h x l x w)	*Weight (Kg)	Fan Rating (A)	Fan Type
	Gross	Nett							
VSO20UT	20.0	18.0	1.9	9.2	7 x 1.7	445x4120x826	104	1.0	2507
VSO25UT	25.0	22.5	2.4	10.0	7 x 1.9	445x4120x826	104	1.0	2507
VSO30UT	32.0	28.8	3.1	11.5	7 x 2.1	445x5955x826	142	1.0	2507
VSO35UT	36.0	32.4	3.5	11.5	7 x 2.3	445x5955x826	142	0.5	2560
VSO40UT	40.0	36.0	3.8	11.0	7 x 2.7	445x5955x826	142	0.5	2560
VSO45UT	44.0	39.6	4.2	11.6	7 x 2.9	445x7760x826	182	0.5	2560
VSO50UT	48.0	43.2	4.6	12.8	7 x 2.5L	445x7760x826	182	0.5	2560

VSO15UT	15.0	13.5	1.4	10.2	7 x 1.3	298x4049x826	97	0.5	2501
VSO20UT	20.0	18.0	1.9	11.0	7 x 1.5	298x4049x826	97	0.5	2501
VSO25UT	25.0	22.5	2.4	9.2	7 x 1.8	298x4049x826	97	0.5	2501
VSO30UT	32.0	28.8	3.1	10.8	7 x 2.0	298x5884x826	135	1.0	2507
VSO35UT	36.0	32.4	3.5	9.0	7 x 2.3	298x5884x826	135	0.5	2560
VSO40UT	40.0	36.0	3.8	8.0	7 x 2.7	298x5884x826	135	0.5	2560
VSO45UT	44.0	39.6	4.2	8.9	7 x 2.9	298x7689x826	175	0.5	2560
VSO50UT	48.0	43.2	4.6	9.1	7 x 2.5L	298x7689x826	175	0.5	2560

Heater Model	Heat Input kW		Gas Flowrate (m³/hr)	Injector Pressure (mbar)	Injector Size (mm)	*Size (h x l x w)	*Weight (Kg)
	Gross	Nett					
VSO15UH	15.0	13.5	1.4	10.2	7 x 1.3	298x4049x826	97
VSO20UH	20.0	18.0	1.9	11.0	7 x 1.5	298x4049x826	97
VSO25UH	25.0	22.5	2.4	9.2	7 x 1.8	298x4049x826	97
VSO30UH	32.0	28.8	3.1	10.8	7 x 2.0	298x5884x826	135
VSO35UH	36.0	32.4	3.5	9.0	7 x 2.3	298x5884x826	135
VSO40UH	40.0	36.0	3.8	8.0	7 x 2.7	298x5884x826	135
VSO45UH	44.0	39.6	4.2	8.9	7 x 2.9	298x7689x826	175
VSO50UH	48.0	43.2	4.6	9.1	7 x 2.5L	298x7689x826	175

Note* For Optima heaters fitted with decorative end mouldings, Length increases by a further 1056mm, weight increases by 6Kg

Table 6. Induced VSO Herringbone Settings - Natural Gas (G20)

Heater Model	Cold HB Pressure		Hot HB Pressure	
	mm H ₂ O	mbar	mm H ₂ O	mbar
VSO15UH	14.3	1.4	10.2	1.0
VSO20UH	18.4	1.8	10.2	1.0
VSO25UH	25.5	2.5	17.3	1.7
VSO30UH	14.3	1.4	10.2	1.0
VSO35UH	22.4	2.2	16.3	1.6
VSO40UH	20.4	2.0	17.3	1.7
VSO45UH	33.6	3.2	22.4	2.2
VSO50UH	33.6	3.2	22.4	2.2

Table 7. Flue details - Natural Gas (G20)

Heater Model	Mass Flow Rate of Flue Gasses (kg/s)	Flue Pressure (Pa) Max Flue Resistance	Flue Gas Temp (°C)
VSO20UH	0.0130	19	185
VSO25UH	0.0139	13	205
VSO30UH	0.0165	33	180
VSO35UH	0.0167	7.5	185
VSO40UH	0.0183	35	220
VSO45UH	0.0210	31	185
VSO50UH	0.0224	10	195
VSO15UH	0.0114	6	165
VSO20UH	0.0125	19	190
VSO25UH	0.0137	28	225
VSO30UH	0.0189	29	205
VSO35UH	0.0207	24	235
VSO40UH	0.0253	28	240
VSO45UH	0.0253	26	210
VSO50UH	0.0257	27	220

Tables 8. Burner Settings - Propane Gas (G31)

Heater Model	Heat Input kW		Flowrate (l/hr)	Injector Pressure (mbar)	Injector Size (mm)	*Size (h x l x w)	*Weight (Kg)	Fan Rating (A)	Fan Type
	Gross	Nett							
VSO15UT	15.0	13.9	2.18	13.5	7 x 1.0	298x4049x826	97	0.5	2501
VSO20UT	20.0	18.5	2.88	12.4	7 x 1.2	298x4049x826	97	1.0	2507
VSO25UT	25.0	23.1	3.60	13.3	7 x 1.3	298x4049x826	97	1.0	2507
VSO30UT	32.0	29.6	4.60	22.5	7 x 1.3	298x5884x826	135	0.5	2560
VSO35UT	36.0	33.3	5.12	22.4	7 x 1.4	298x5884x826	135	0.5	2560
VSO40UT	40.0	37.0	5.68	18.4	7 x 1.5	298x5884x826	135	0.5	2560
VSO45UT	44.0	40.7	6.25	14.9	7 x 1.7	298x7689x826	175	0.5	2560
VSO50UT	48.0	44.4	6.82	14.3	7 x 1.8	298x7689x826	175	0.5	202126

Heater Model	Heat Input kW		Flowrate (l/hr)	Injector Pressure (mbar)	Injector Size (mm)	*Size (h x l x w)	* Weight (Kg)
	Gross	Nett					
VSO15UH	15.0	13.9	2.18	13.5	7 x 1.0	298x4049x826	97
VSO20UH	20.0	18.5	2.88	12.4	7 x 1.2	298x4049x826	97
VSO25UH	25.0	23.1	3.60	13.3	7 x 1.3	298x4049x826	97
VSO30UH	32.0	29.6	4.60	22.5	7 x 1.3	298x5884x826	135
VSO35UH	36.0	33.3	5.12	22.4	7 x 1.4	298x5884x826	135
VSO40UH	40.0	37.0	5.68	18.4	7 x 1.5	298x5884x826	135
VSO45UH	44.0	40.7	6.25	14.9	7 x 1.7	298x7689x826	175
VSO50UH	48.0	44.4	6.82	14.3	7 x 1.8	298x7689x826	175

Note* For Optima heaters fitted with decorative end mouldings, Length increases by a further 1056mm, weight increases by 6Kg

Table 9. Induced VSO Herringbone Settings - Propane Gas (G31)

Model	Cold HB Pressure		Hot HB Pressure	
	mm H ₂ O	mbar	mm H ₂ O	mbar
VSO15UH	19.4	1.9	15.3	1.5
VSO20UH	22.4	2.2	17.3	1.7
VSO25UH	24.5	2.4	17.3	1.7
VSO30UH	27.5	2.7	19.4	1.9
VSO35UH	31.6	3.1	20.4	2.0
VSO40UH	38.7	3.8	23.5	2.3
VSO45UH	36.7	3.6	23.5	2.3
VSO50UH	36.7	3.6	28.6	2.8

Table 10. Flue details - Propane Gas (G31)

Heater Model	Mass Flow Rate of Flue Gasses (kg/s)	Flue Pressure (Pa) Maximum Flue Resistance	Flue Gas Temp (°C)
VSO15UT	0.0152	12.5	182
VSO20UT	0.0200	24.9	214
VSO25UT	0.0196	15.0	232
VSO30UT	0.0201	16.2	210
VSO35UT	0.0238	27.4	240
VSO40UT	0.0255	29.9	247
VSO45UT	0.0210	31.4	233
VSO50UT	0.0334	43.6	228

2. Assembly Instructions.

i **PLEASE READ** this section prior to assembly to familiarise yourself with the components and tools you require at the various stages of assembly. Carefully open the packaging and check the contents against the parts and check list.

The manufacturer reserves the right to alter specifications without prior notice.

i Please ensure that all packaging is disposed of in a safe environmentally friendly way.

i For your own safety we recommend the use of safety boots and leather faced gloves when handling sharp or heavy items. The use of protective eye wear is also recommended.

2.1 Tools Required.

The following tools and equipment are advisable to complete the tasks laid out in this manual.



2.2 Assembly Notes (refer fig's 11-17)

2.2.1 Tubes

Identify and position tubes (A) on trestles. Position the tubes so that the tube seams are facing inwards.

Mark out the position of the bracket centres from the dimensions shown on the assembly drawings.

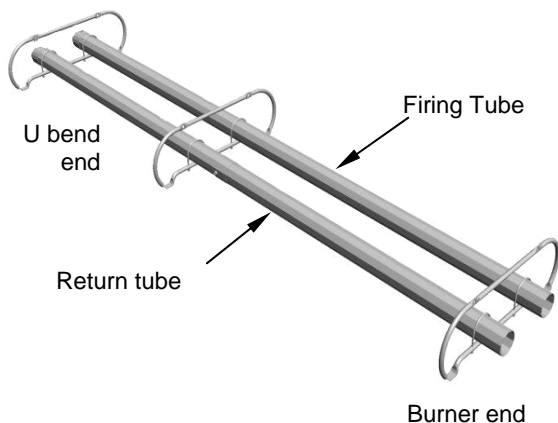

Note:
i Four module heaters (45kW & 50kW) are assembled in two sections.

Note:
! First section of burner tube on PROPANE four module heaters (45kW & 50kW) is stainless steel.

2.2.2 Brackets

Slide the bracket assemblies (B) along to the tubes to the dimensional positions and in their correct order as detailed in the assembly drawings. We recommend brackets are fixed to tubes prior to hanging.

! When fixing the bracket to the tubes it should be noted that the 'U' bolts on the first bracket **CLOSEST TO THE BURNER*** and last bracket **CLOSEST TO 'U' BEND** should be tightened to achieve a minimum torque setting of 15Nm².

* not on the firing tube on 2 module versions

! All remaining 'U' bolts on the **RETURN TUBE** should also be tightened to achieve a minimum torque setting of 15Nm².

! All remaining 'U' bolts on the **FIRING TUBE** and the first 'U' bolt on the **FIRING TUBE** on 2 module variants, should be left loose and locked in place with a locknut to achieve a 3mm clearance above the tube to allow for thermal expansion (see sketch below).

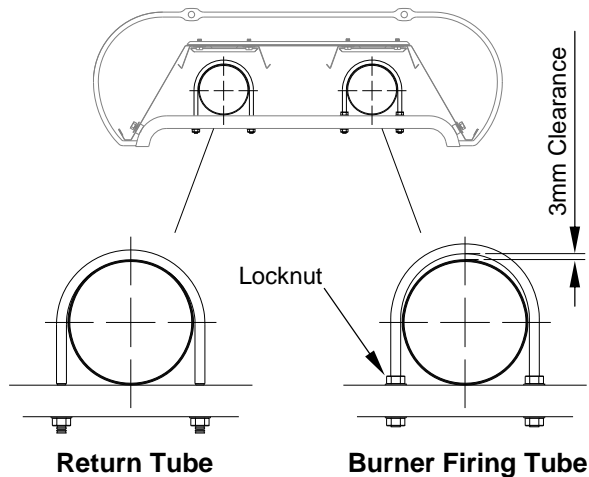

2.2.3 Turbulators

There are various lengths of turbulators (G) for the vision range. Identify correct lengths prior to assembly. We recommend turbulators are inserted into tubes prior to hanging.

Insert short 976mm turbulator into burner firing tube from **U BEND END**.

For models 15, 20 and 25: Insert 3400mm turbulator into return tube from **U BEND END**.

For models 30, 35 and 40: Insert one 2600mm turbulator into return tube from **U BEND END** and one 2600mm turbulator into return tube from **OPPOSITE END**.

For models 45 and 50: Insert one 3040mm turbulator into return tube from **U BEND END** and one 3400mm* turbulator into return tube from **OPPOSITE END**. *Nat gas only



View from U tube end

2.2.4 Couplers

For fixing the U bend. Locate and position tube couplers (D) Slide the coupler over the components ensuring that the rivet stop has butted up to the tube end and the pre-fitted bolts engage in the pre-cut holes so that the socket heads are **FACING INWARDS**.



Moving between the two set pins, tighten both ensuring that equal pressure is applied to each set pin in turn.

2.2.5 Coupler Bellows

For adjoining tubes on 3 and 4 module heaters, locate and position the coupler (Q) onto the ends of the tubes after firstly positioning a clamp on both ends. Slide each clamp onto the bellow ends.

Moving between the two set pins, tighten both ensuring that equal pressure is applied to each set pin in turn.

i There is one bellow located on the firing tube on models 30, 35 & 40:
There are two bellows located on each tube on models 45 and 50:

i Due to the length of models 45 and 50, the coupler bellows are assembled onto the tube ends **ONCE** the two halves of the heater have been fully assembled and hung in position see "Final Fixings" section 2.2.7.2.3

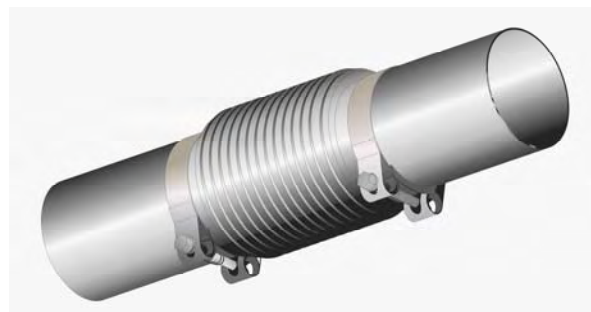
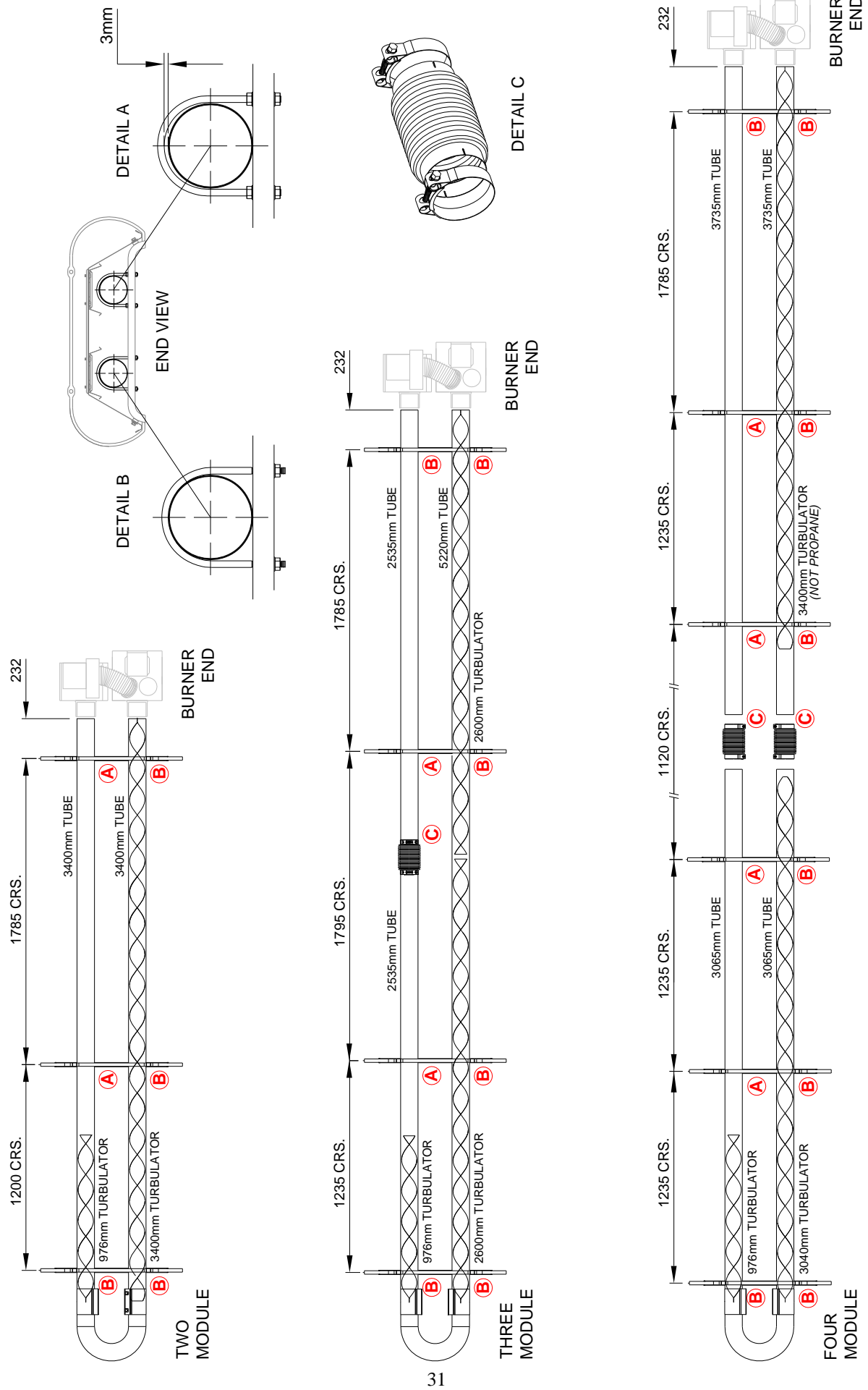



Fig. 11 Tube, Brackets and Turbulator detail



2.2.6 U Bend.

Slide U bend (C) into the open end of the couplers ensuring the pre-fitted bolts engage in the pre-cut holes. Tighten all four clamping bolts to provide a tight grip between tubes & U bend.

 To avoid damaging the heater whilst installing we recommend the heater chassis be suspended prior to fitting reflectors.

2.2.7 Reflectors

There are three reflector section types used in the construction on the Vision Optima heater.

1. Overshield reflector (J): located on the underside of the inner reflector positioned above and in parallel to the radiant tubes. The two ends of the overshields are different to allow for thermal expansion and should be fixed in the correct order as detailed in the assembly drawings.

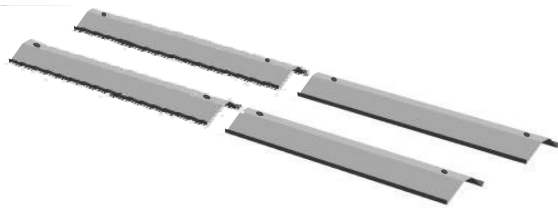

2. Inner Reflector (H): aluminised steel reflectors located over the radiant tubes to emit the heat downwards.

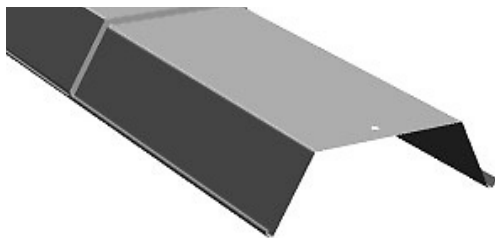

3. Outer Canopy (L): pre-coated decorative reflector positioned to the outside of the reflector. The outer canopies come in two halves for ease of assembly and are held together by closing plates (N).

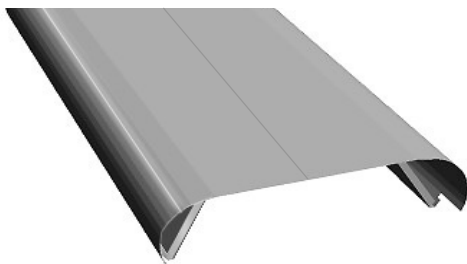

2.2.7.1 Overshield Reflectors

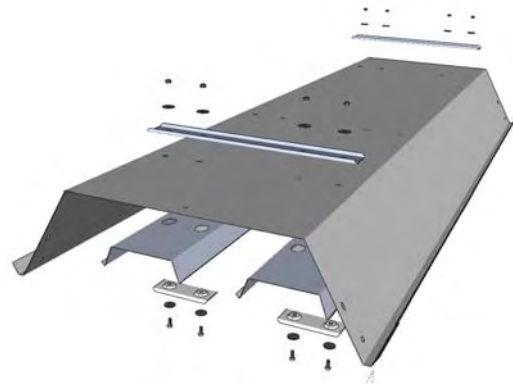

 **Remove the protective plastic coating.**
Overshields MUST be fitted prior to the assembly of the reflectors.

Overshields (J1) are fitted to the underside of, and run in parallel to, the inner reflectors.

One end of the overshield has two holes for direct fixing to the reflector, the other end has two larger slots which along with an expansion fixing plate allows for thermal expansion.

 **The overshields are supplied in two lengths and MUST be arranged, in the correct directions and on the specific reflector order as indicated in the detailed drawings.**

1. Locate and position correct overshield and offer to the underside of the reflector so that the location holes are in line.

2. Using bolts, nuts and washers provided, fasten through the overshield, reflector and cross member (J2) which runs across the top.

3. The larger holes located at the other end of the overshield should line up with the holes in the reflector. This end is allowed to 'float' with thermal expansion and as such, an expansion plate (J3) is added and placed to the underside of the overshield.

4. Using bolts, nuts and washers provided, fasten through the expansion plate, overshield, reflector and cross member which runs across the top.

5. Continue for other reflectors.

Fig. 12 Overshield detail

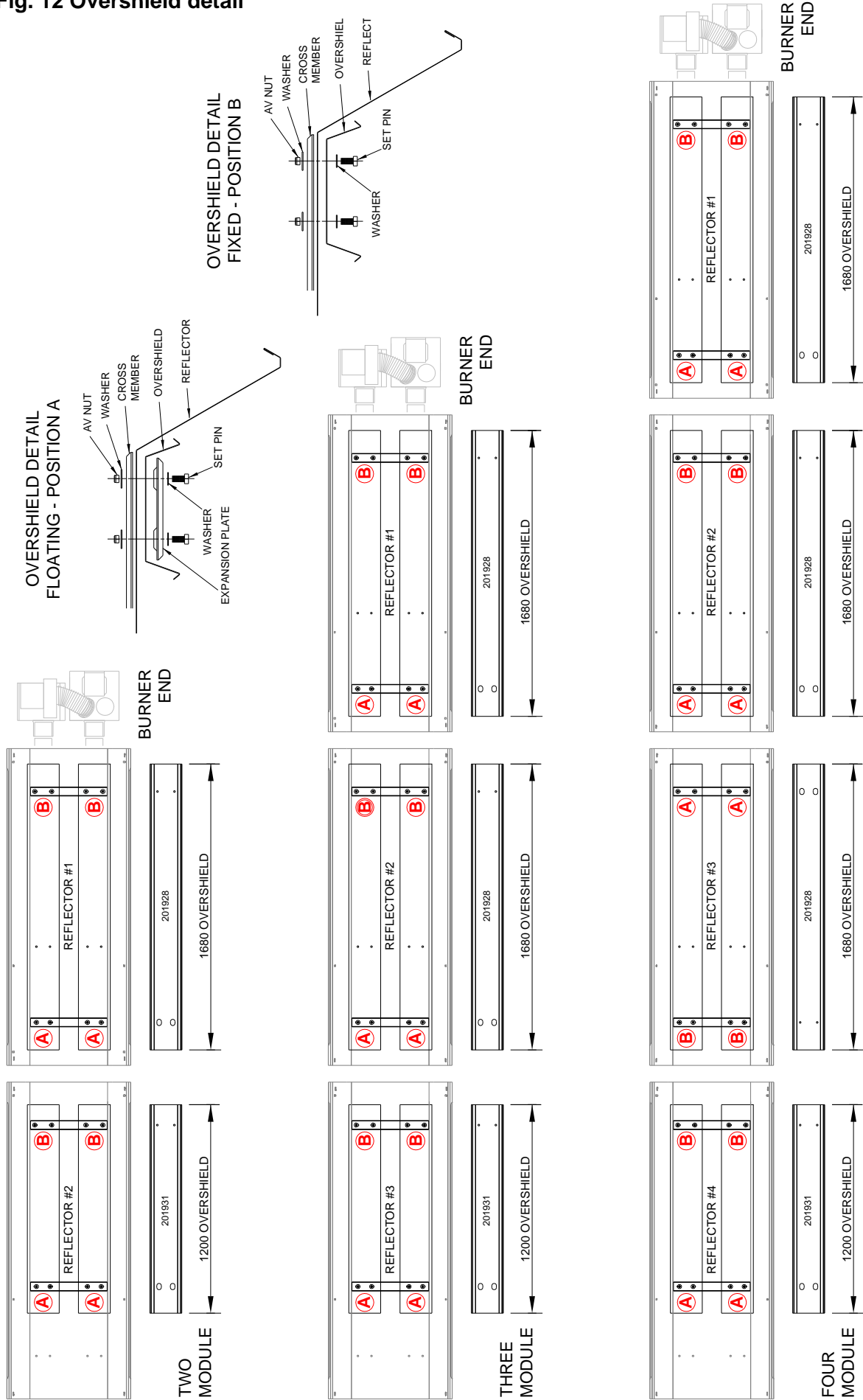

2.2.7.2 Inner Reflectors

 All reflectors must be positioned/ attached to the brackets exactly as detailed in the assembly drawings.

Remove the protective plastic coating.

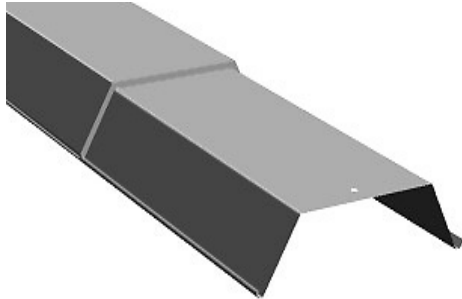

2.2.7.2.1 Two Module units

1. Place inner reflectors (H) on the heater by sliding the reflectors between the tubes and the brackets.
2. Locate the FIRST slot on reflector over the M8 bolt on the first bracket. Secure using large washers and anti vibration nuts.
3. The slot in other end of the first reflector should align with M8 bolt on the second bracket.
4. Locate the second reflector onto the same bolt using the SECOND slot in from the end and OVERLAP the first reflector. This should create a 114mm overlap. Secure using large washers and anti vibration nuts.

 **Ensure the 2nd reflector sits on top of the 1st.**

4. Locate the M8 bolts on last bracket to slot in second reflector approx one third distance from reflector end. Secure using large washers and anti vibration nuts.
5. Slight re-adjustment of brackets may be necessary for reflector alignment. Ensure U bolts are tightened correctly as described in section 2.2.3.

2.2.7.2.2 Three Module Units

1. Place inner reflectors (H) on the heater by sliding the reflectors between the tubes and the brackets.
2. Locate the FIRST slot on reflector over the

M8 bolt on the first bracket. Secure using large washers and anti vibration nuts.

3. The slot in other end of the first reflector should align with M8 bolt on the second bracket.
4. Locate the second reflector onto the same bolt using the FIRST slot in from the end and OVERLAP the first reflector. This should create a 77mm overlap. Secure using large washers and anti vibration nuts.
5. The slot in other end of the second reflector should align with M8 bolt on the third bracket.
6. Locate the third reflector onto the same bolt using the FIRST slot in from the end and OVERLAP the second reflector. This should create a 67mm overlap. Secure using large washers and anti vibration nuts.

 **Ensure the 3rd reflector sits on top of the 2nd reflector and the 2nd reflector on top of the 1st**

7. Locate the M8 bolts on last bracket to slot in third reflector approx one third distance from reflector end. Secure using large washers and anti vibration nuts.
8. Slight re-adjustment of brackets may be necessary for reflector alignment. Ensure 'U' bolts are tightened correctly as described in section 2.2.3.

2.2.7.2.3 Four Module Units.

Models 45 and 50 are assembled in two halves.

Working on the half closest to the Burner:

1. Place the first two inner reflectors (H) on the heater by sliding the reflectors between the tubes and the brackets.
2. Locate the FIRST slot on reflector over the M8 bolt on the first bracket on this half. Secure using large washers and anti vibration nuts.
3. The slot in other end of the first reflector should align with M8 bolts on the second bracket on this half.
4. Locate the second reflector onto the same bolt using the FIRST slot in from the end and OVERLAP the first reflector. This should create a 77mm overlap. Secure using large washers and anti vibration nuts.



Ensure the 2nd reflector sits on top of the 1st.

5. Locate the M8 bolts on third bracket on this half to slot in same reflector approx one third distance from reflector end. Secure using large washers and anti vibration nuts.

Now working on the second half:

6. Place the remaining inner reflectors (H) on the heater by sliding the reflectors between the tubes and the brackets.



Note: Third reflector ONLY is turned through 180° to all other reflectors.

7. Locate the fourth reflector onto the M8 bolts of the first bracket on this half using the slot approx one third distance in from the end of the reflector. Secure using large washers and anti vibration nuts.

8. The last slot in other end of this reflector should align with M8 bolts on the second bracket on this half.

9. Locate the fourth reflector onto the same bolts using the FIRST slot in from the end and OVERLAP the third reflector. This should create a 84mm overlap. Secure using large washers and anti vibration nuts



Ensure the 4th reflector sits on top of the 3rd.

10. Locate the M8 bolts on last bracket to slot in fourth reflector approx one third distance from reflector end. Secure using large washers and anti vibration nuts.

11. Slight re-adjustment of brackets may be necessary for reflector alignment. Ensure 'U' bolts are tightened correctly as described in section 2.2.3.

Final fixings for four module units.

12. At this stage, with the bellow couplers already affixed to one half, align and offer other side of bellow couplers to adjoining tubes, carefully overlapping the second reflector to the third to create a 50mm overlap. Secure using bolts, large washers and anti vibration nuts.

13. Tighten bellow couplers as stated in section 2.2.5

14. With the assembly correctly fitted, a gap of 1120mm between brackets 3 and 4 should be apparent.

2.2.8 Insulation mats.

Using the recommended safety equipment i.e. gloves, goggles and a face mask, cover the back of reflectors with the insulation mats. Tuck in the edge of the mat behind the lip of the reflector.

The insulation mats come in two sections for the four module variants.

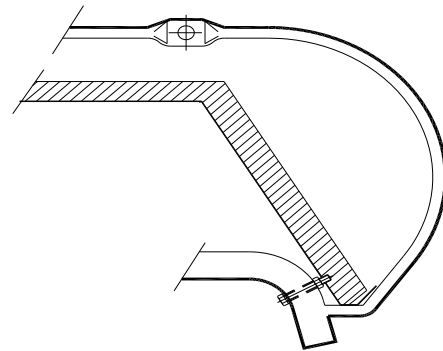
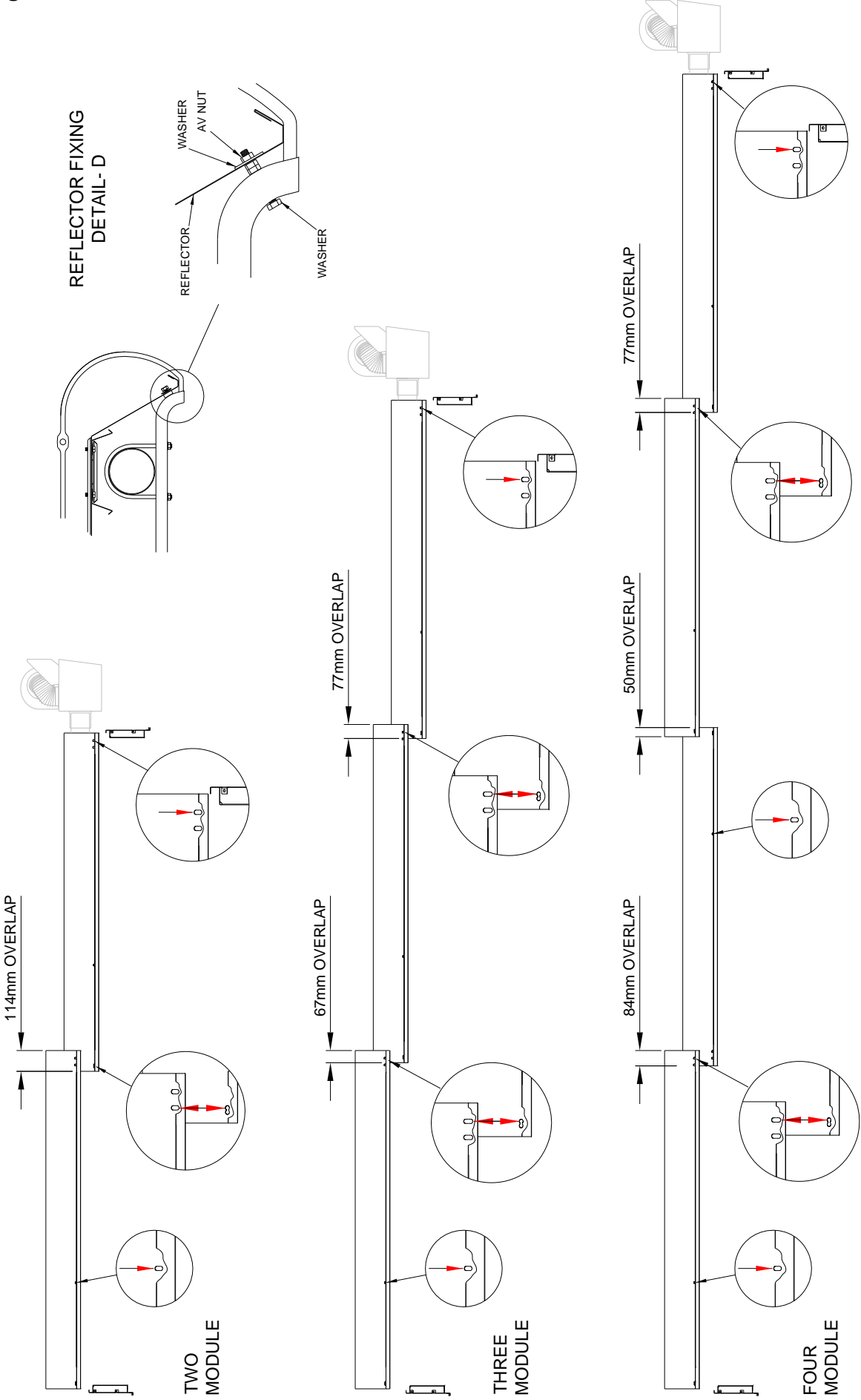
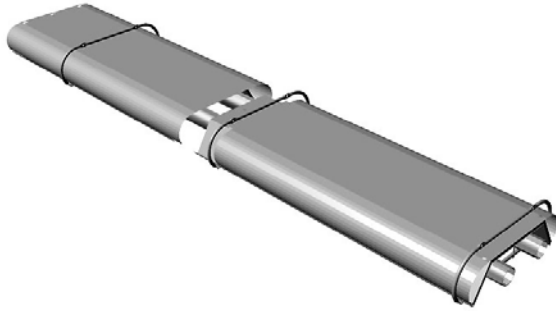

Fig. 13 Reflector detail



2.2.9 Outer Canopy's



Remove the protective plastic coating.

The outer canopies are made up of identical half covers (L) which engage into the side of the inner reflectors and join at the centre by way of a closing plate which holds the two halves together. Install the outer canopies using the following method;

2.2.8.1 Two Module Units

1. Slide on the two halves to cover the 1st section of the heaters and fit closing plates to each end to the second set of canopies.
2. Slide on two more outer canopies.
3. Stop short of the canopies already fitted and fit closing plates (N).
4. Insert the ends of the second set of canopies inside the first set at the central joint.
5. A slot is located 15mm from the end of each canopy. Align each slot i.e. one on top of each other and insert M8 self tapping screws provided.

2.2.8.2 Three Module Units

1. Slide on the two halves to cover the centre section of the heaters and fit closing plates to each end (P).
2. Slide on two more outer canopies.
3. Stop short of the canopies already fitted and fit closing plates (P).
4. Insert the ends of the second set of canopies inside the first set at the central joint.
5. A slot is located 15mm from the end of each canopy. Align each slot i.e. one on top of each

other and insert M8 self tapping screws provided.

6. Repeat the procedure for 3rd set of outer canopies.

2.2.9.3 Four Module Units

1. Slide on the two halves to cover the centre section of the heaters and fit closing plates to each end (P).
2. Slide on two more outer canopies.
3. Stop short of the canopies already fitted and fit closing plates (P).
4. Insert the ends of the second set of canopies inside the first set at the central joint.
5. A slot is located 15mm from the end of each canopy. Align each slot i.e. one on top of each other and insert M8 self tapping screws provided.
6. Repeat the procedure for 3rd and 4th set of outer canopies.

Fig. 14 Canopy detail

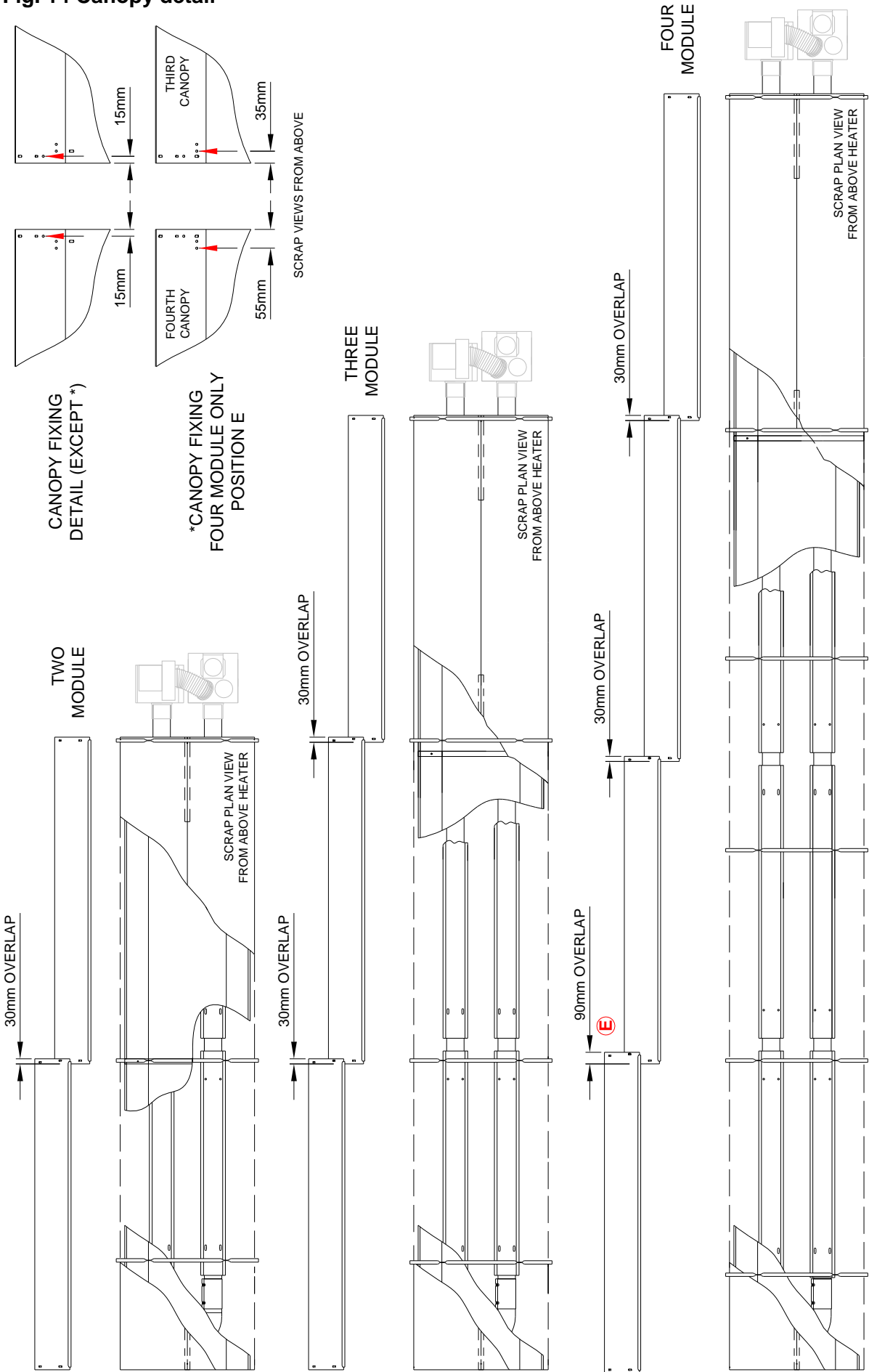

2.2.10 End Caps

 **Remove the protective plastic coating.**

Position the end cap with no tube holes (M) beneath the reflector profile at the U bend end making sure that the end cap engages inside the inner reflector . Fasten to canopy using M5 pozi set pin and washers.

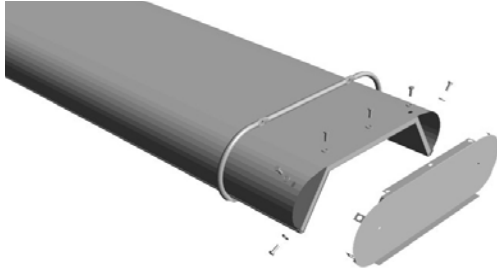

Position the end cap with tube holes beneath the reflector profile at the burner end making sure that the end cap engages inside the inner reflector . Fasten to canopy using M5 pozi set pin and washers.

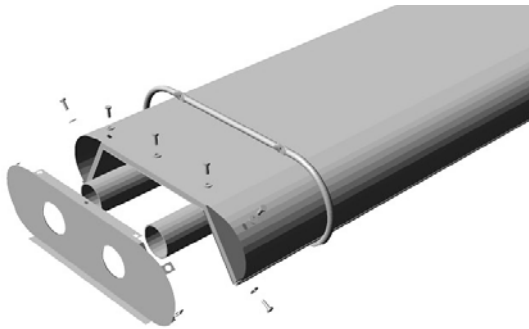

2.2.11 Burner Assembly.

Slide the burner assembly (F) onto the **RIGHT HAND TUBE** when viewed from behind, ensuring it is fully engaged. Secure with grub screws.

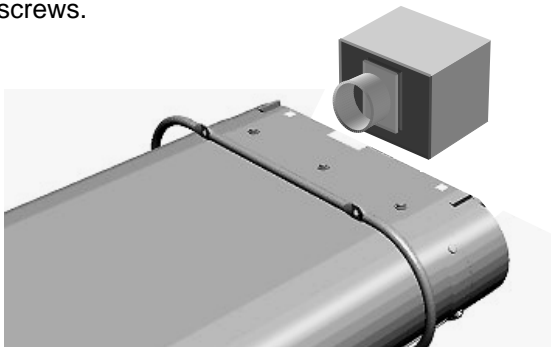

2.2.12 Heat Exchanger Assembly

On VSXO only, slide the heat exchanger assembly (E1) onto the **LEFT HAND TUBE** when viewed from behind ensuring it is fully engaged. Secure with pinch screws.

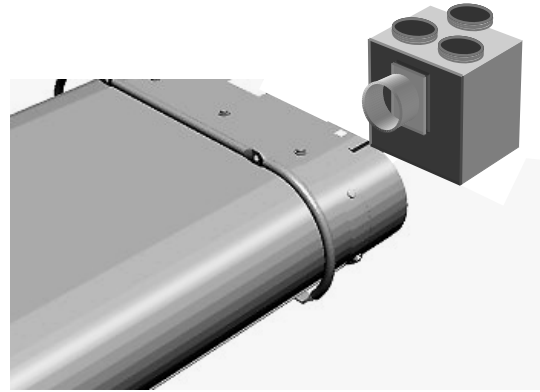

2.2.13 Fan Assembly

On unitary heaters only, slide the fan assembly (E2) onto the **LEFT HAND TUBE with the test point closest to the tube** when viewed from behind ensuring it is fully engaged. Secure with pinch screws.

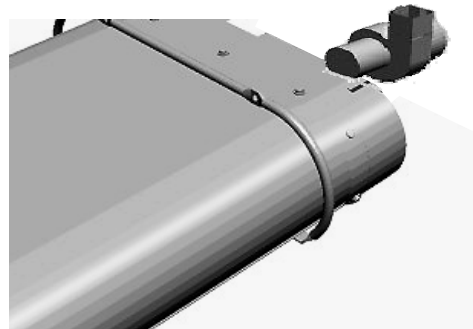

2.2.14 Herringbone Damper Assembly

On Herringbone heaters only, slide the damper assembly (E3) onto the **LEFT HAND TUBE with the test point closest to the tube** when viewed from behind ensuring it is fully engaged. Secure with pinch screws.

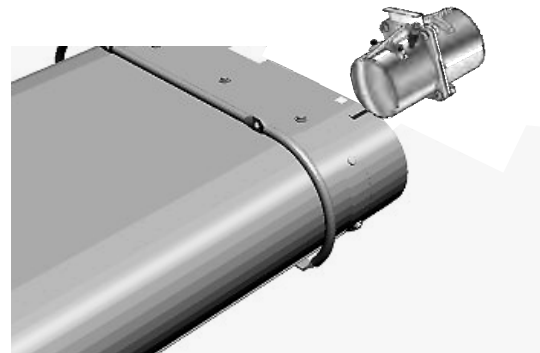

Note: The damper assembly must be located with its damper blade vertical and left in the closed position. The manifold tube is to be sealed and secured (as described below) to the damper assembly.

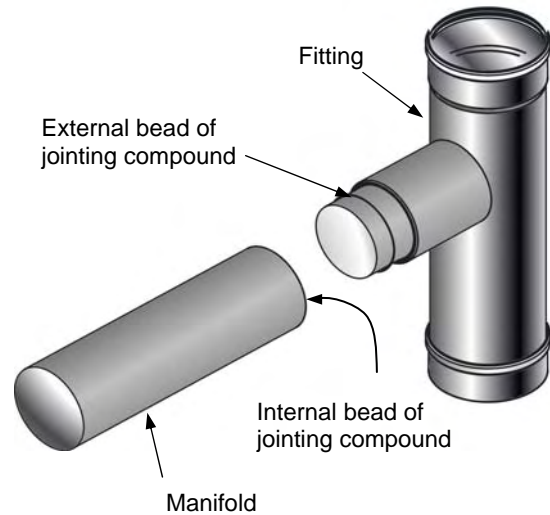
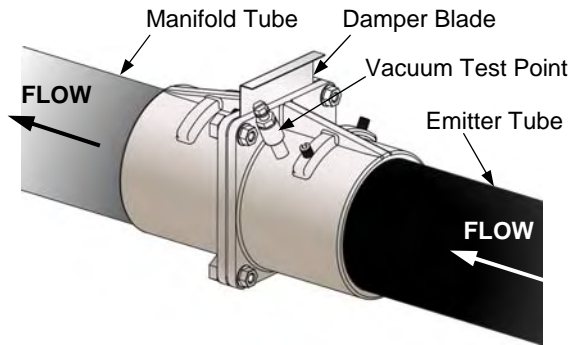

2.2.15 Fixing of optional End Mouldings.

If end mouldings (P) have been ordered (optional item) fit the end mouldings with the screws provided / quick release clips to the holes in top of the canopy.

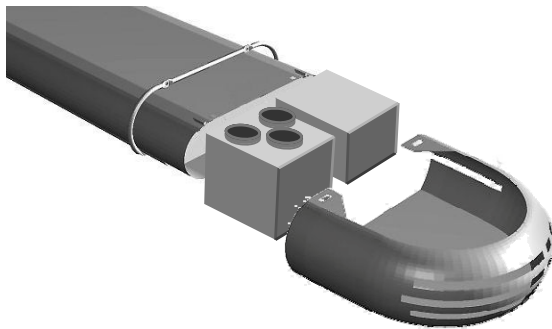

Note The silicon jointing compound remains workable after application for only 5 minutes.

Secure the joint by drilling through the tube and fitting and fix with three pop rivets at 12 o'clock, 4 o'clock and 8 o'clock positions. 4.8mm (3/16in) diameter pop rivets are recommended.

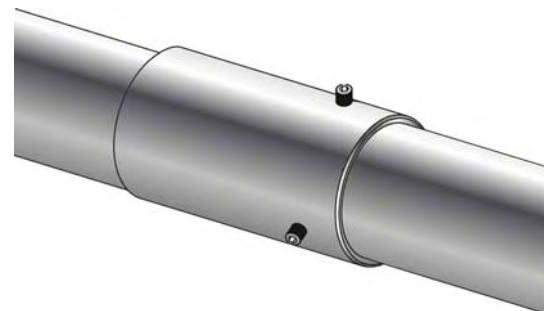

2.2.16 HB Manifold Assembly.

VSO Models ONLY. After fixing the heaters in the desired position, the manifold system requires fitting.

After allowing for a minimum of 75mm (3in) of penetration of the fitting into the tube, cut the tubes to the lengths required and remove all burrs and wipe off any grease or oil with a clean rag.

Method of jointing aluminium tube

Using the applicator gun exude 4mm diameter bead of high temperature silicon jointing compound externally round the end of the fitting and internally round the end of the tube.

Enter the fitting into the tube using a slight rotating movement to spread the jointing compound uniformly until a penetration of 75mm (3in) is achieved.

2.2.17 Detailed Assembly Drawings

The following pages show the exploded diagrams of the VSO and VSXO range of heaters.

Please note the heater type, length and reference number from the delivery/advice note before identifying the correct model drawing

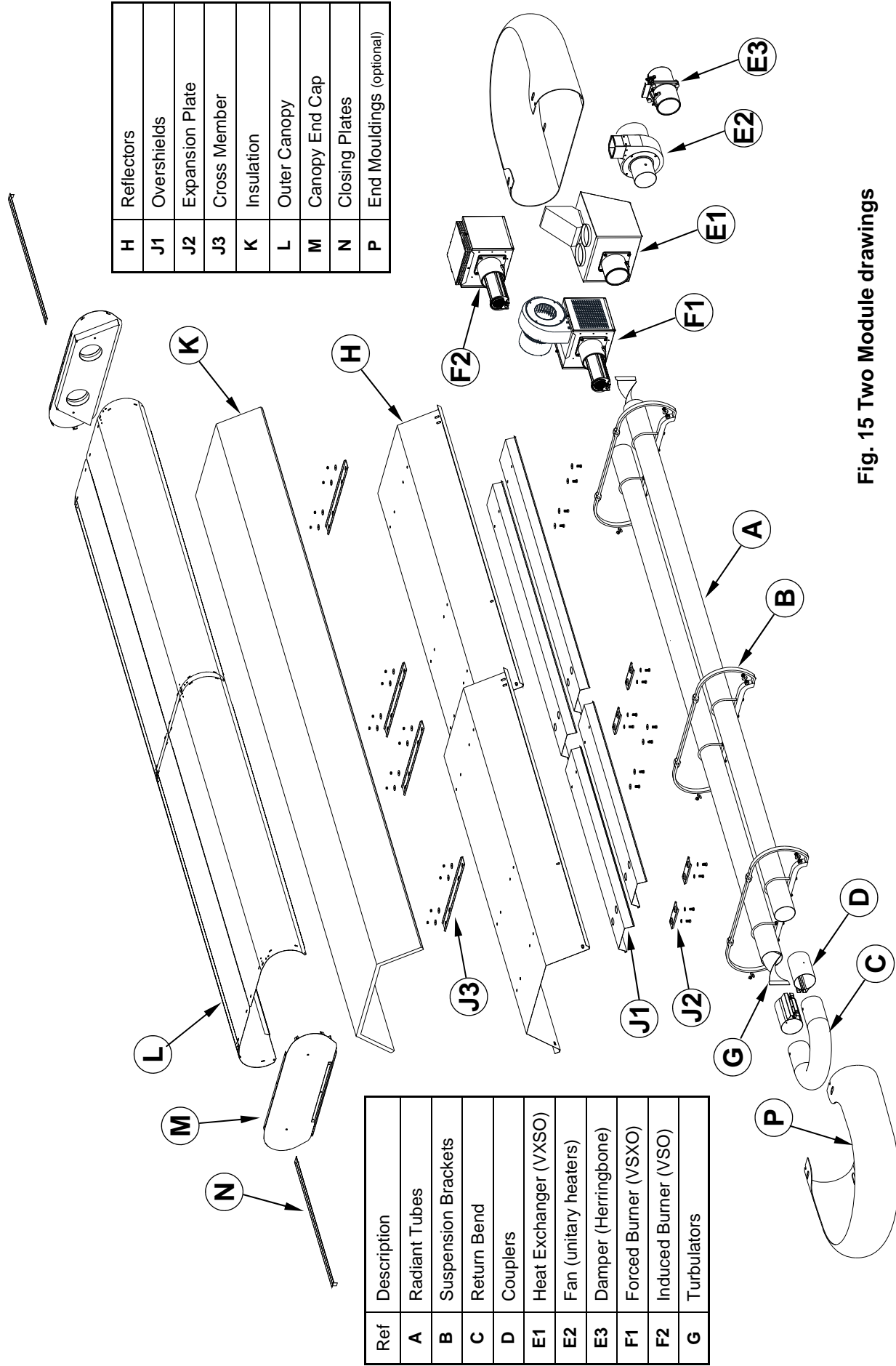

Ref	Description
A	Radiant Tubes
B	Suspension Brackets
C	Return Bend
D	Couplers
E1	Heat Exchanger (VXSO)
E2	Fan (unitary heaters)
E3	Damper (Herringbone)
F1	Forced Burner (VSXO)
F2	Induced Burner (VSO)
G	Turbulators

H	Reflectors
J1	Overshields
J2	Expansion Plate
J3	Cross Member
K	Insulation
L	Outer Canopy
M	Canopy End Cap
N	Closing Plates
P	End Mouldings (optional)

Fig. 15 Two Module drawings

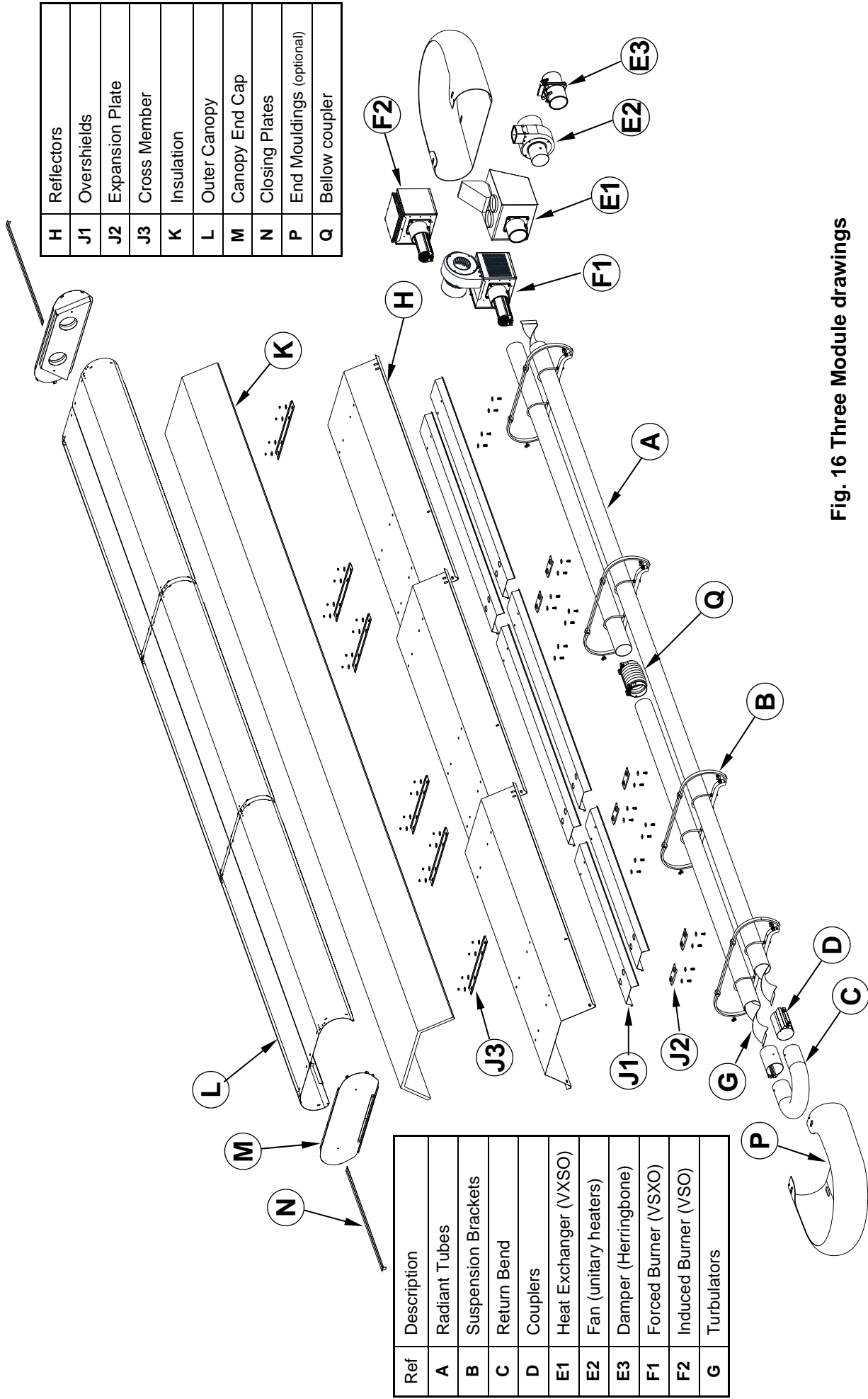

H	Reflectors
J1	Overshields
J2	Expansion Plate
J3	Cross Member
K	Insulation
L	Outer Canopy
M	Canopy End Cap
N	Closing Plates
P	End Mouldings (optional)
Q	Below coupler

Ref	Description
A	Radiant Tubes
B	Suspension Brackets
C	Return Bend
D	Couplers
E1	Heat Exchanger (VXSO)
E2	Fan (unitary heaters)
E3	Damper (Herringbone)
F1	Forced Burner (VXSO)
F2	Induced Burner (VSO)
G	Turbulators

Fig. 16 Three Module drawings

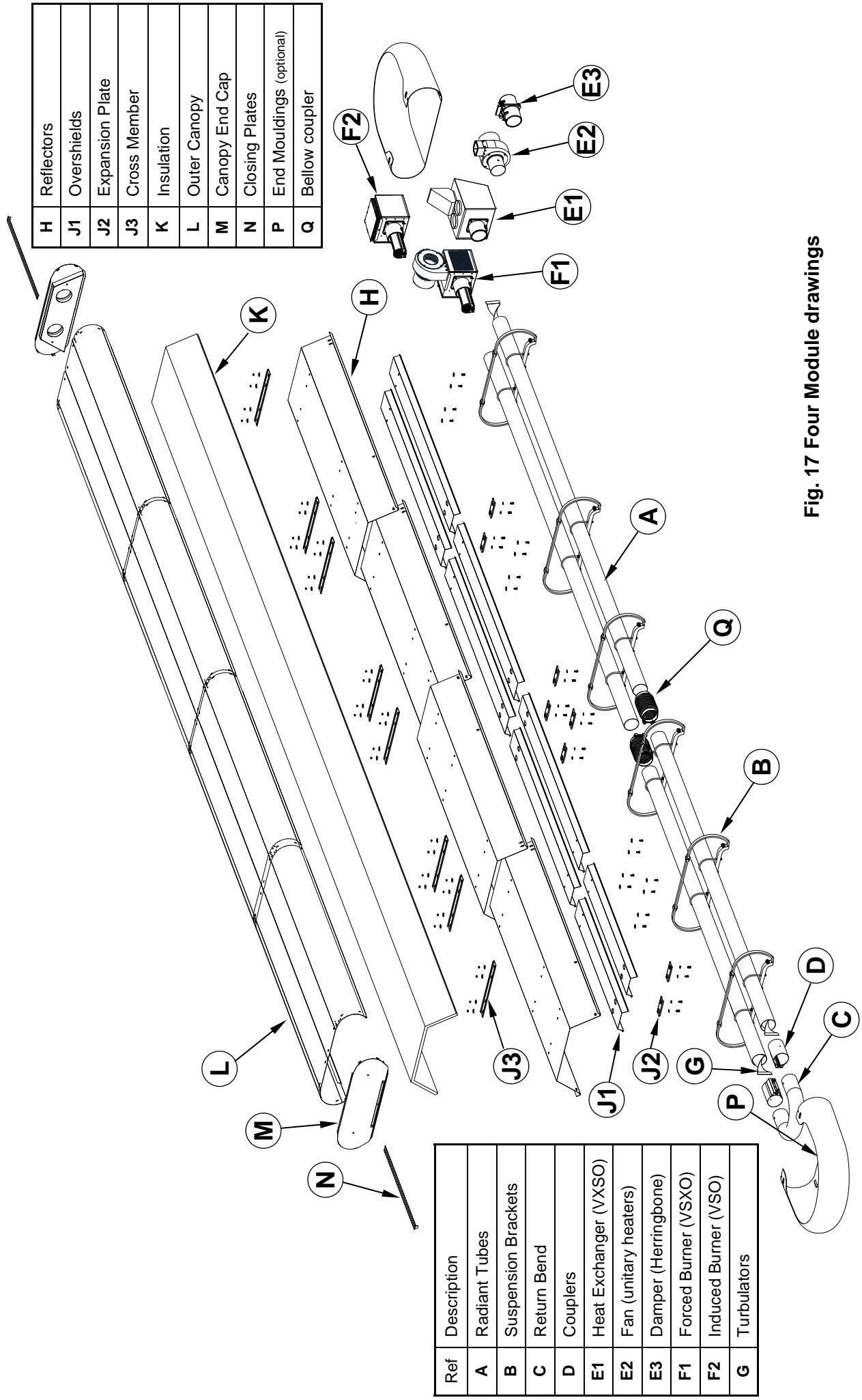

Fig. 17 Four Module drawings

3. Commissioning Instructions.

! These appliances should be commissioned by a qualified engineer.

3.1 Tools Required.

The following tools and equipment are advisable to complete the tasks laid out in this manual.

i Suitable alternative tools may be used.

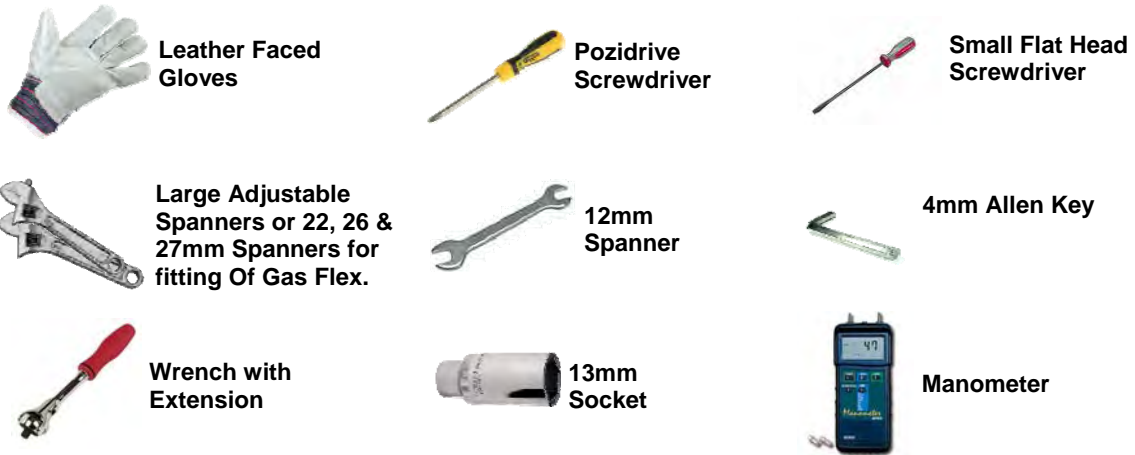

3.2 Balancing The Herringbone System

! *Important. When all the heaters have been installed the vacuum settings must be finally balanced in the hot condition.*

Before attempting to start up the heating system it is essential to perform the preliminary balancing of the vacuum level at each burner unit. Isolate each heater unit by unplugging the electrical connector and closing the gas isolating valve.

Start all burners up and allow them to run for at least 20 minutes.

Adjust the damper at exit of each heater using a 4mm Allen key in the damper blade securing screw. Observing the vacuum reading using a 'U' tube manometer connected to the vacuum test point (see over) each damper should be readjusted and set at a hot condition reading as shown in table 6 for the appropriate size of heater and model.

Figure 18. HB Damper Assembly

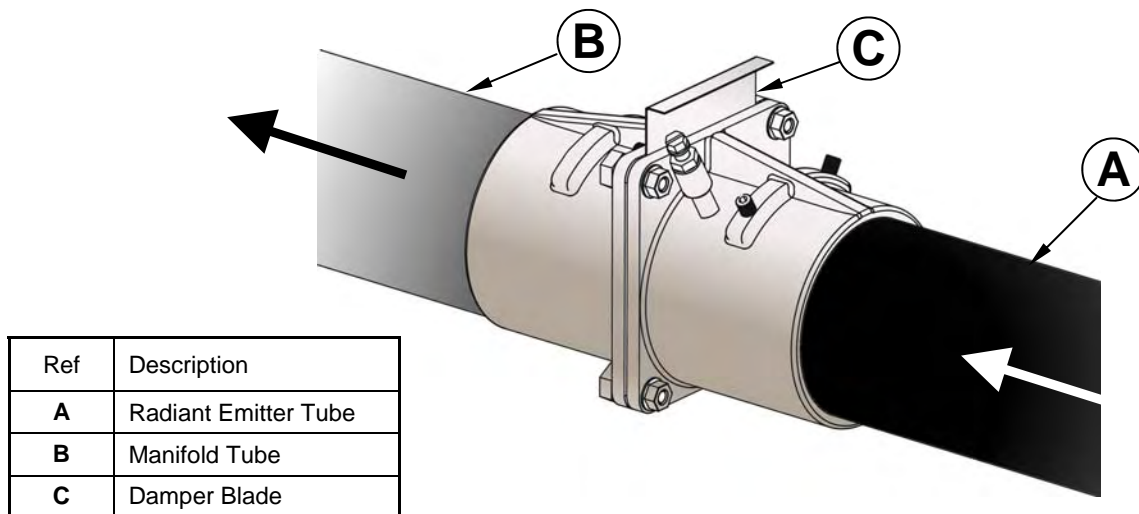

Slacken screw in burner lid and open the right hand burner access door.

The two vacuum impulse hoses are in view. Both hoses are fitted with 'T' pieces, one end of which has a blanking cap.



Connect extra sections of hose to each 'T' piece.



Connect either a digital manometer or U tube gauge to the open ends of the hoses.

Remove each blanking cap.



Check reading against technical data.

3.3 Commissioning chart

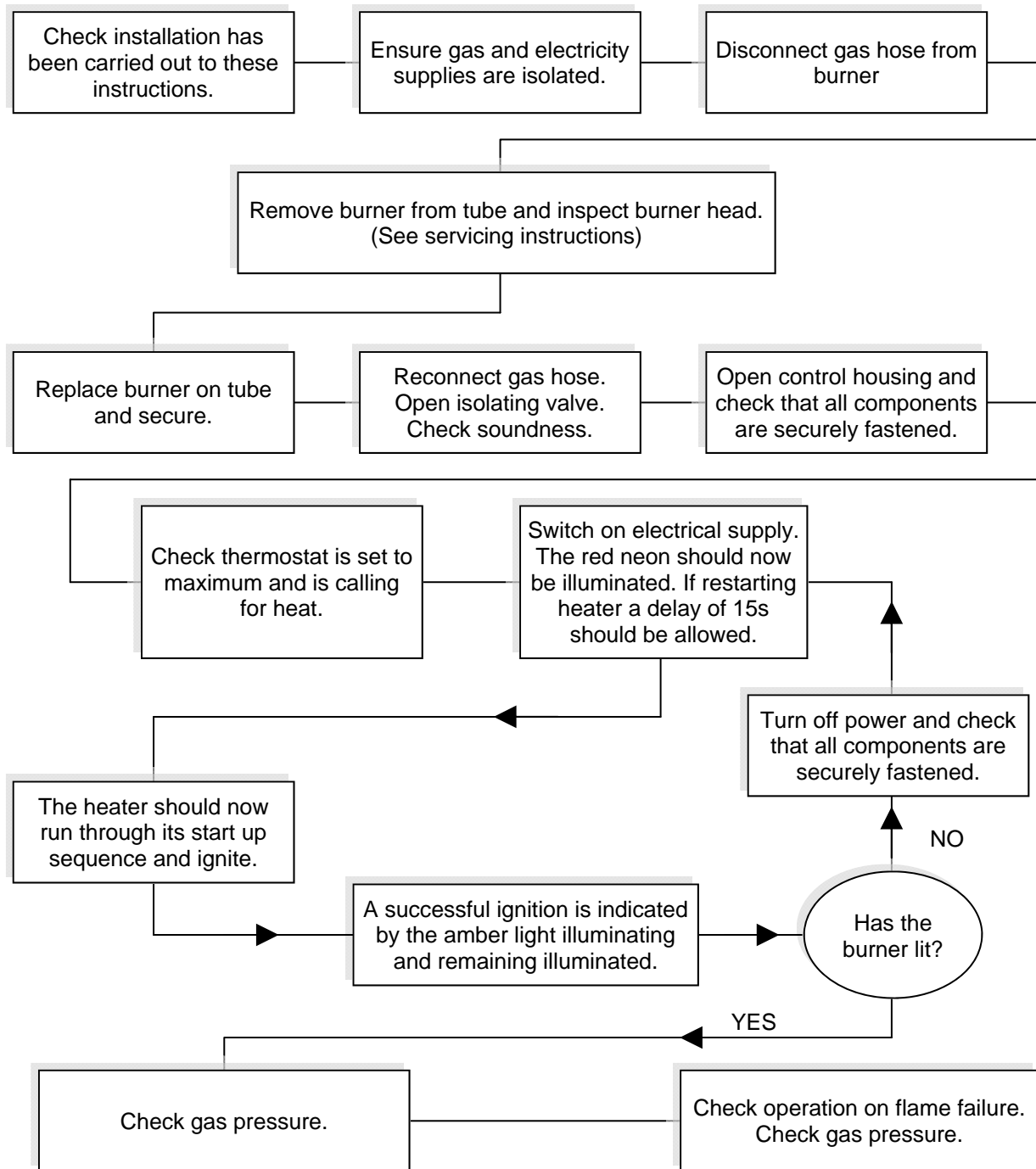
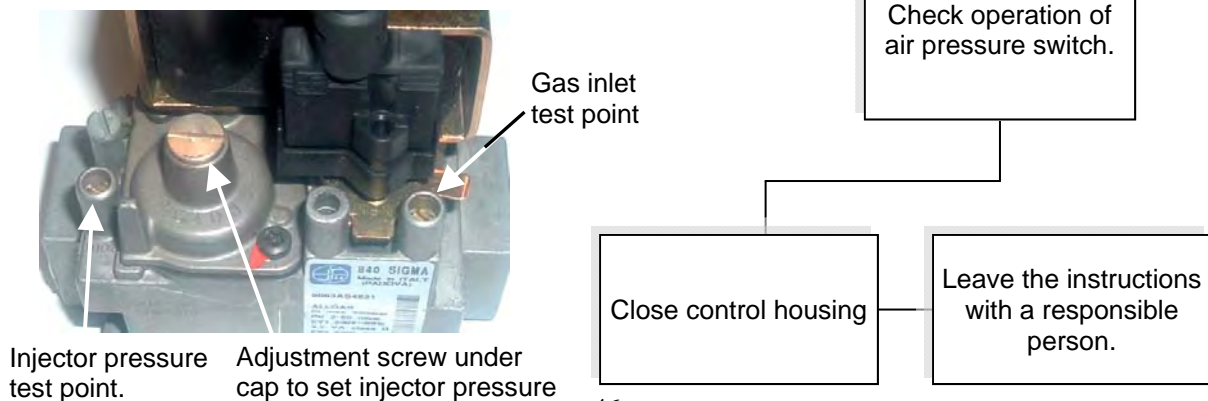

Figure 19. Gas Valve adjustment



4. Servicing Instructions.



These appliances should be serviced annually by a competent person to ensure safe and efficient operation. In exceptional dusty or polluted conditions more frequent servicing may be required. The manufacturer offers a maintenance service. Details available on request

4.1 Tools Required.



Suitable alternative tools may be used.

The following tools and equipment are advisable to complete the tasks laid out in this manual.



4.2 Burner Description.

Figure 20. Induced Herringbone Burner: Model VSO UT/UH (refer to spares section 5)

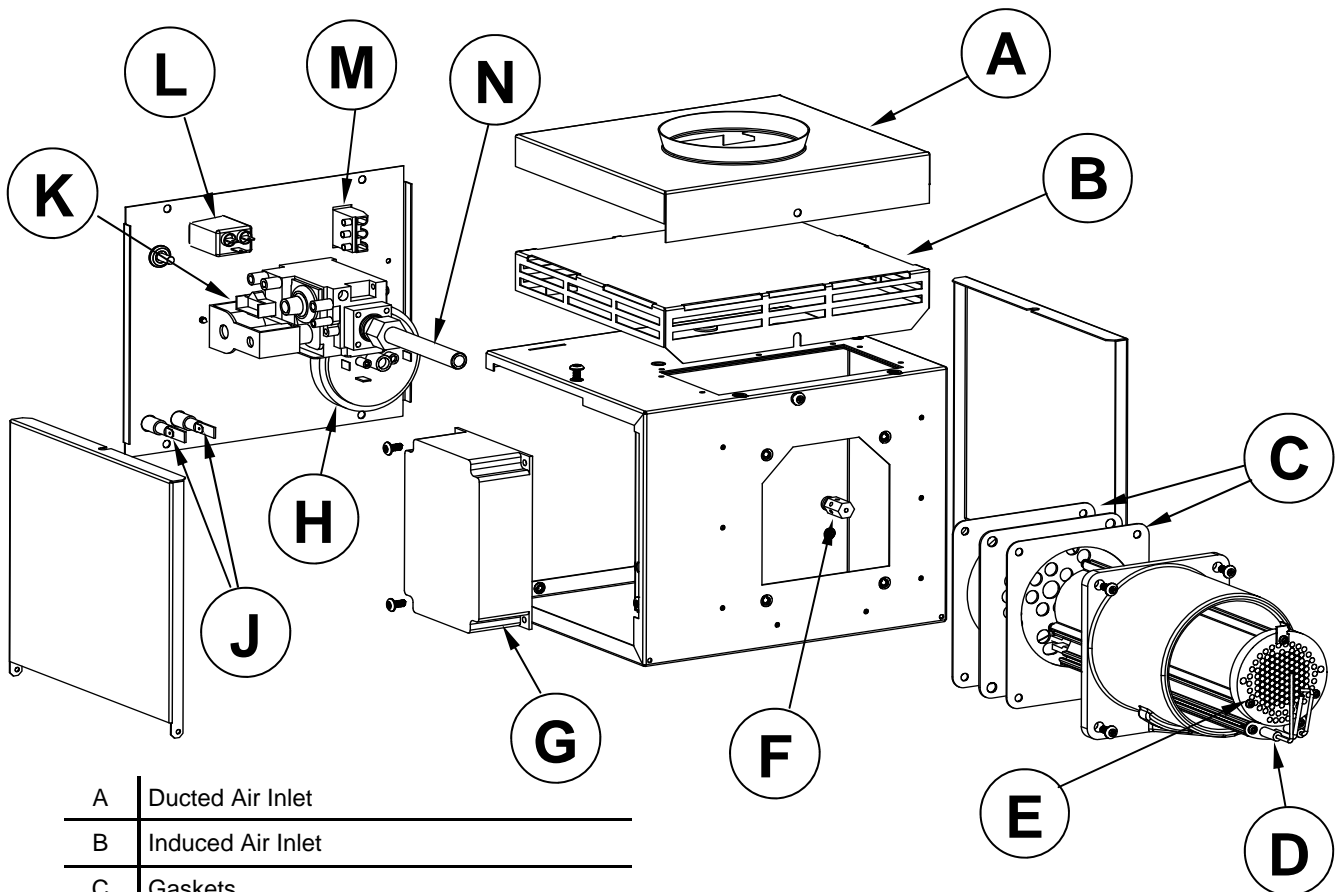

A	Ducted Air Inlet
B	Induced Air Inlet
C	Gaskets
D	Ignitor Assembly
E	Pepperpot Head
F	Multi Hole Injector
G	Ignition Controller
H	Pressure Switch

J	Neon's (Red/Amber)
K	Gas Valve
L	Mains Input Socket
M	Fan Socket
N	Injector Carrier

**Figure 21. Forced Gas Burner:
Model VSXO (refer to spares section 5)**

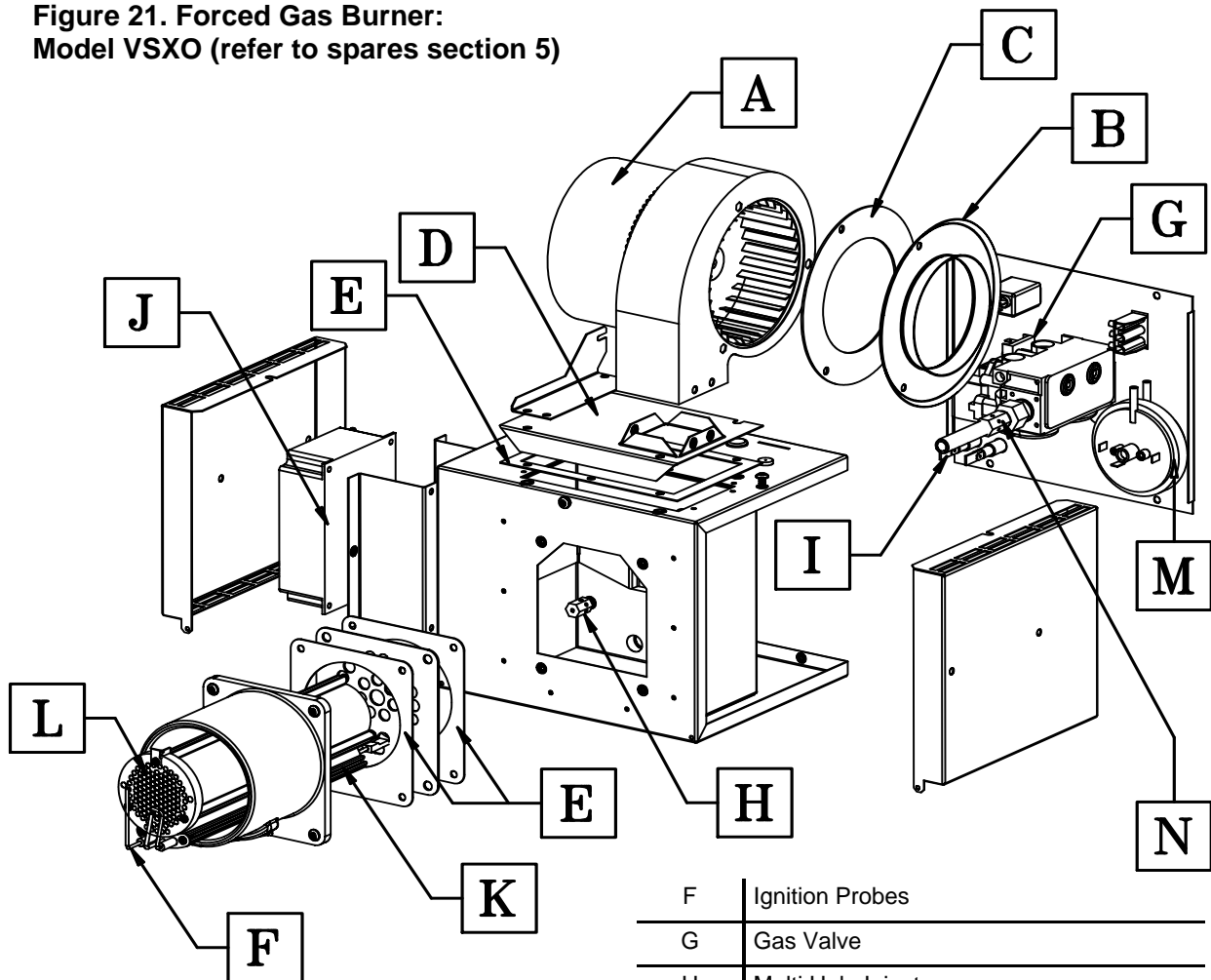

A	2501/2507 or 2560 Fan
B	Fan Inlet Spigot
C	Fan Orifice
D	Fan Mount Plate
E	Fan Mount Plate Gasket
Please refer to spares for burner components	

F	Ignition Probes
G	Gas Valve
H	Multi Hole Injector
I	Neon's (Red/Amber)
J	Ignition Controller
K	Extrusion Burner Head
L	Pepperpot Head
M	Pressure Switch
N	Jet Carrier

4.3 Burner Removal (All Options)

Step 1 Isolate mains electric and gas supplies.

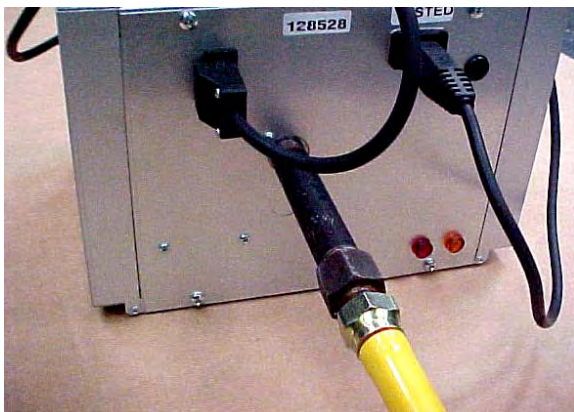

Step 2 Detach the gas supply as shown below, taking care to support the burner connection.

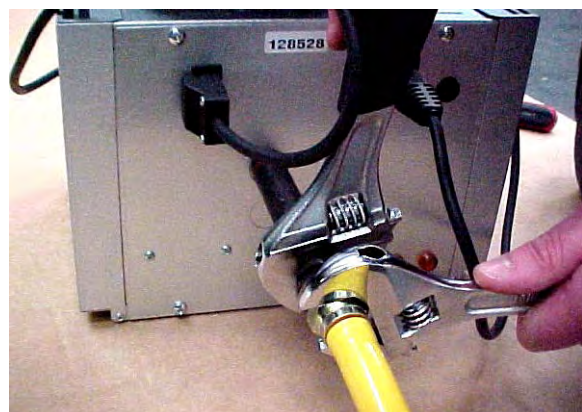

Step 3 On forced burners with ducted air attachment, slacken jubilee clip and remove flexible hose from the fan.

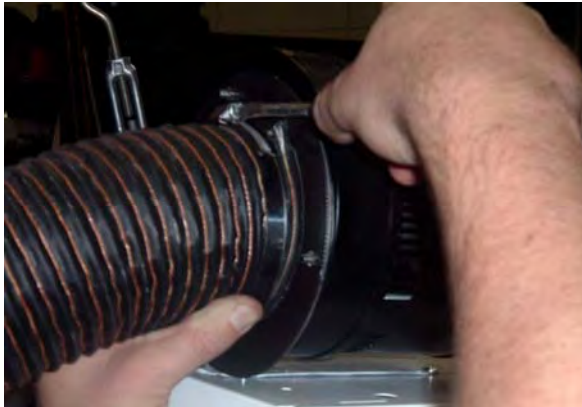

disconnected by separating the connectors of the ignition lead assembly and removing the pressure switch silicon tube.

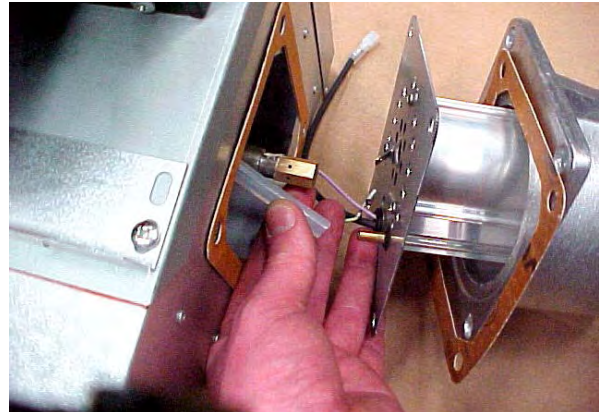

Step 4 Slacken both grub screws on the burner support casting using a 4mm Allen key to enable the burner to be removed from the radiant tube.



Step 3 The gas injector can be inspected and replaced if contaminated or blocked.



i When replacing the gas injector use a 12mm spanner and ensure approved thread sealant is used.

Step 5 Carefully remove the burner to prevent it or any components from falling to the ground and position the assembly in a safe area.

Step 4 Refit the burner support casting and replace the gaskets to ensure effective sealing.

4.4 Burner Gas Injector Servicing

4.5 Burner Head and Electrode Servicing

Step 1 Remove the burner support casting and gasket.

Step 1 Check the pepper pot burner head for contamination. If necessary the head can be removed for cleaning of the inside of the burner head, see below.

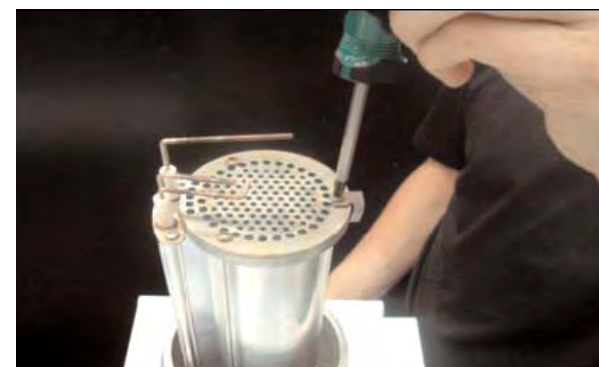
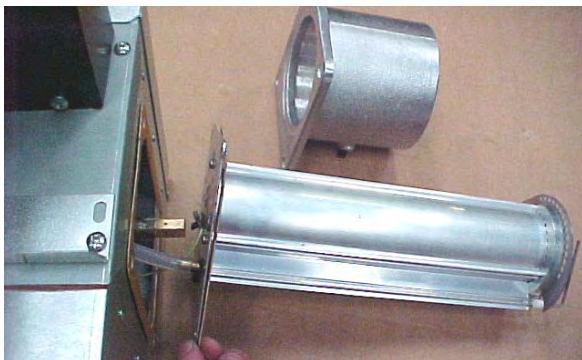

Step 2 The burner head assembly can be

Step 2 The pepper pot burner head can be replaced ensuring the 5 holes on the outer ring are aligned alongside the probes.



Step 3 The condition of the ignitor assembly can be checked for deterioration. However, we advise replacement at each service to ensure continued reliability.

Step 4 Detach the electrode assembly from the burner head by removing the two screws and separating the ignitor lead connectors.

Step 5 Check the positions and spark gap as shown below.

Step 6 The burner assembly is ready to refit after servicing the combustion fan and the radiant tube assembly.

4.6 Combustion Fan Assembly Unitary heaters

Step 1 Loosen the clamp fitting on the flue



Step 2 Loosen the 4mm grub screw and de-tatch the combustion fan.



Step 3 Remove the fan orifice plate spinning.

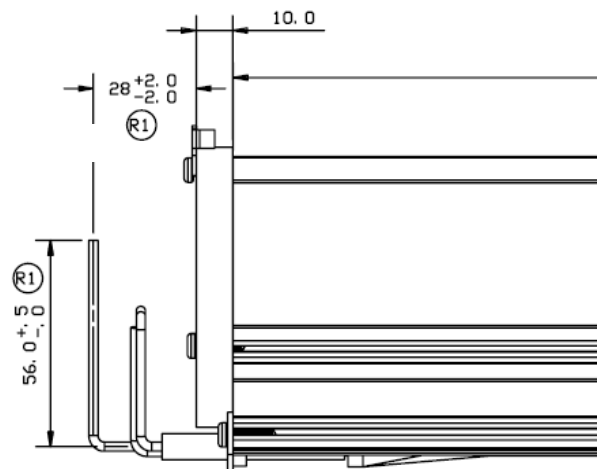
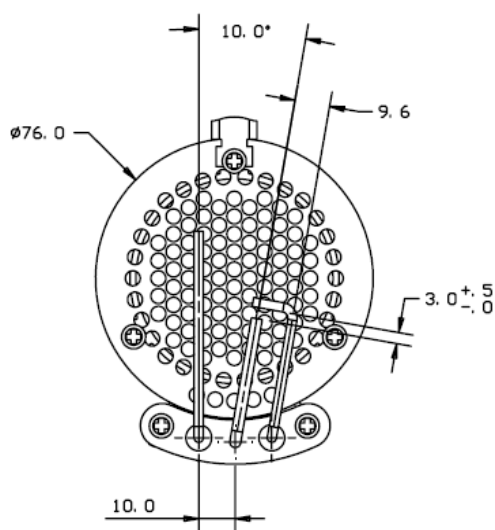

Figure 22. Burner head detail

Step 4 Inspect the impeller and remove any dust with a soft brush.



Step 5 Remove any dust from fan scroll and from around the motor.

Step 6 Ensure the impeller rotates freely.

Step 7 Refit components.

4.7 Combustion Fan Assembly Powered Burner

Step 1 Slacken jubilee clip and remove the flexible hose from the fan.



Step 2 Remove fan fixings.



Step 3 The combustion fan can now be detached.

Step 4 Remove the fan orifice plate spinning.

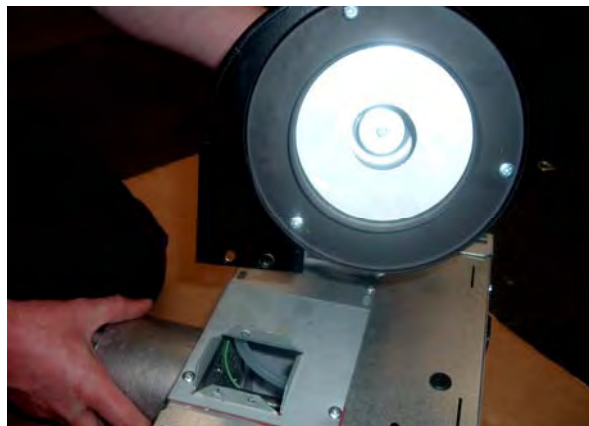

Step 5 Inspect the impeller and remove any dust with a soft brush.

Step 6 Remove any dust from fan scroll and from around the motor.



Step 7 Ensure the impeller rotates freely.

Step 8 Refit components.

4.8 Radiant Tube Servicing

Step 1 Brush any dust from the exterior of the tubes.

Step 2 Inspect the fan and burner tubes visually. If the tubes appear clean, skip to servicing the reflector.

Step 3 Remove the U bend



Step 4 Withdraw the turbulators from the appliance. Carefully noting their condition and position. Replace turbulators if necessary.



Step 5 The turbulators should be cleaned with a soft brush.



Step 6 If required the interior of the tubes can then be cleaned using an industrial vacuum cleaner or by using long poles and a scraper.

Step 7 Refit components.

4.9 Heat Exchanger Servicing

Step 1 Remove the flue connections.



Step 2 Slacken casing support screws and remove heat exchanger from the radiant tube.

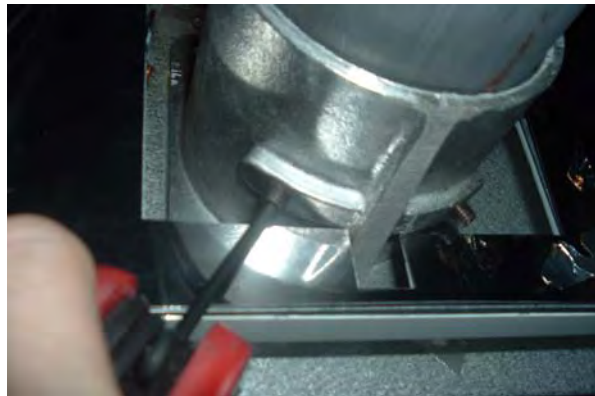

Step 3 Remove any dust and dirt from the heat exchanger & refit.

4.10 Reflector Servicing

The condition of the reflectors should be noted. If necessary the reflectors can be cleaned with a mild detergent.

This can significantly improve the efficiency of the appliance.

4.11 Inspection of Flue

The flue needs to be inspected and cleaned if necessary or in accordance to the regulations of the country that the appliance is installed.

4.12 Re-commissioning After Service

After servicing of the heater has been undertaken, it will be necessary to re-commission the heater as detailed in Section 3 of these instructions.

5. Spare Parts.

Required Spares (refer to section 4.2)

In order to aid troubleshooting and servicing we recommend that the components shown in this section should be stocked.

Note Any spare part components that are not approved by AmbiRad could invalidate the approval of the appliance and validity of the warranty.

Item	Description	Part No.	Item	Description	Part No.
	Ignition Controller	2015S		Pressure Switch: VSXO (Red) VSO (Green)	201676 201508
	Twin Gas Valve: Nat Gas Propane	201587 201914		Amber Neon (Burner On)	2175
	Pepperpot Head	200988		Red Neon (Mains On)	2180
	Ignitor Assembly	201284		Combustion Fan	See Section 1.11
	Extruded Burner Head	200358		Jet Carrier	200420
	Injector	See section 1.11		Jet Carrier (VSO / VSXO50 NG)	201630
	Gasket Set	201488		Flame Plates: (VSO15/20/25 NG & VSXO20/25 NG) (VSO15/20/25/30 Propane) (VSO35/40/45/50 Propane)	201854 201571 201905
	Ducted Air Hose	201321		Cables: Spark Electrode (black) Rectification lead (purple) Earth lead (green/yellow) GV Mini Harness	900225-2 900225-3 900225-1 900375
	Hose Clamp	7541			

6. Fault Finding Guide.

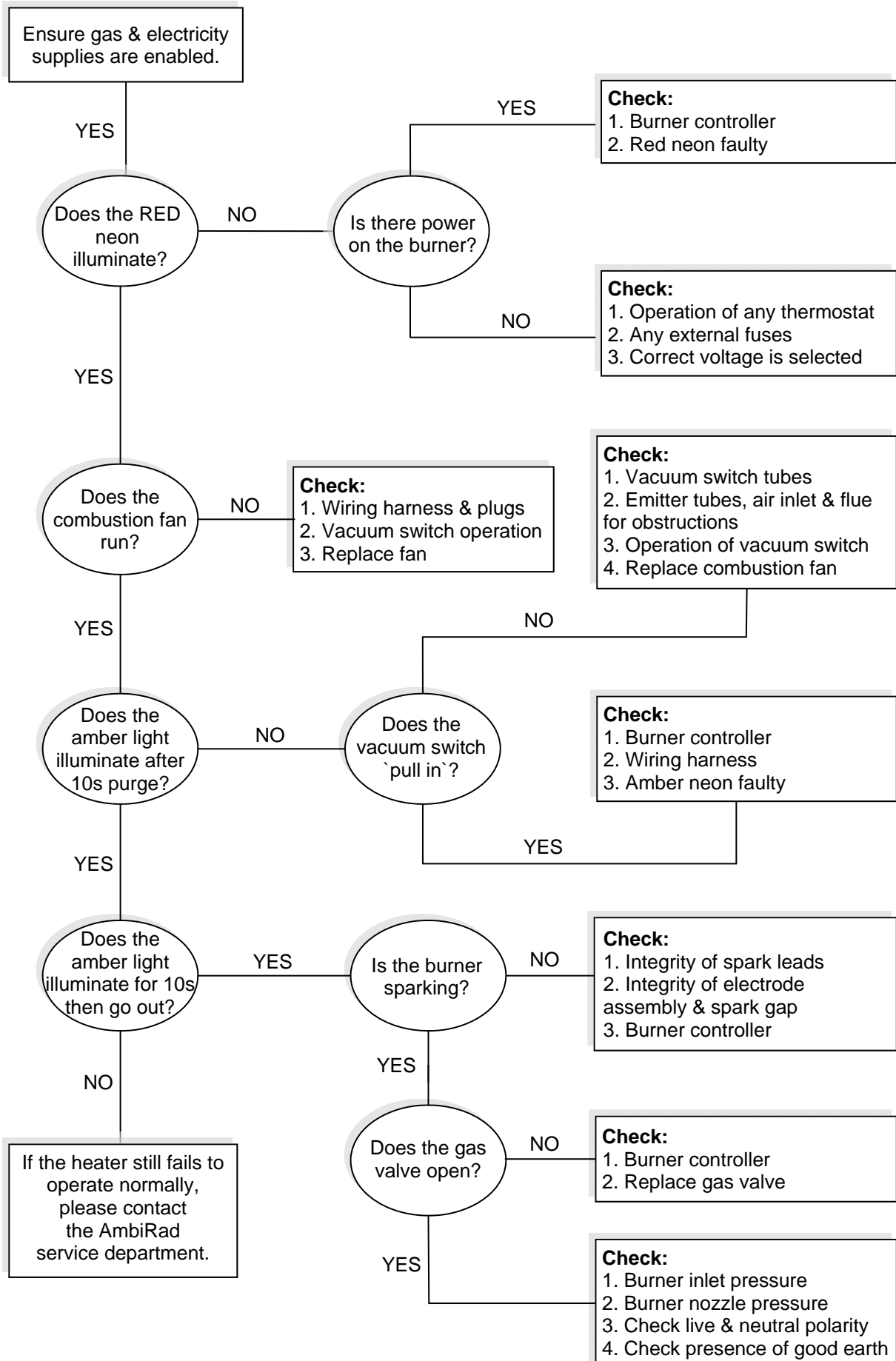

7. Replacing Parts.

7.1.1 Burner Controller Replacement (VSXO)

Step 1 Slacken screw in burner lid and open the right hand burner access door.

Step 2 Undo 2 screws from controller bracket and remove. Disconnect burner controller from the wiring harness.



Step 3 Disconnect the HT Lead from burner controller.



Step 4 Remove the four screws attaching the controller to the bracket and remove.

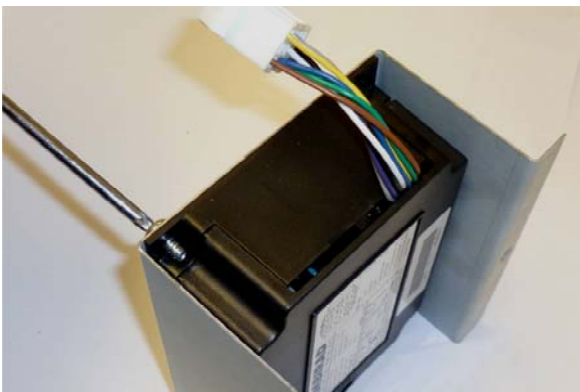

Step 5 Fit new burner controller

Step 6 Refit HT leads and refit burner controller to wiring harness.

Step 7 Test product and close access doors.

7.1.2 Burner Controller Replacement (VSO)

Step 1 Slacken screw in burner lid and open the right hand burner access door.

Step 2 Disconnect burner controller from the wiring harness.



Step 3 Disconnect the HT Lead from burner controller.



Step 4 Remove the two screws attaching the controller to the burner and remove.



Step 5 Fit new burner controller

Step 6 Refit HT leads and refit burner controller to wiring harness.

Step 7 Test product and close access door.

7.2 Air Pressure Switch Replacement

Step 1 Disconnect the two silicone impulse tubes and three wiring connections making note of replacement positions.



Step 2 Remove the two screws as shown below.



Step 3 The air pressure switch can now be removed.

Step 4 Fit the new air pressure switch ensuring the impulse tubes are connected as shown below.

Step 5 Test product and close access doors.



7.3 Gas Valve Replacement

Step 1 Remove the burner assembly as described in the section 4.3 Servicing.

Step 3 Open the left hand access door and detach the impulse hoses from the air pressure switch.



Step 4 Remove the 4 screws holding the burner head onto the burner assembly.

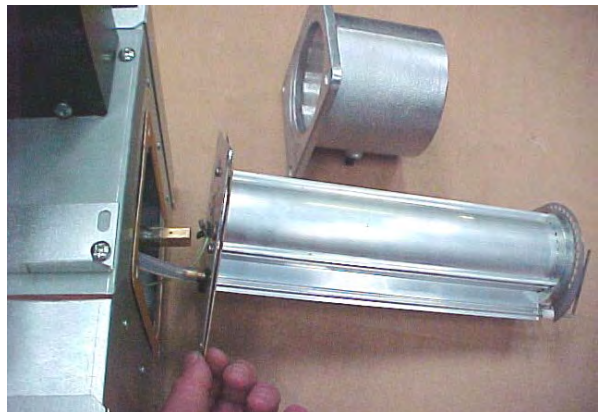

Step 5 The burner head can now be detached by disconnecting the impulse tube and the burner head wiring.

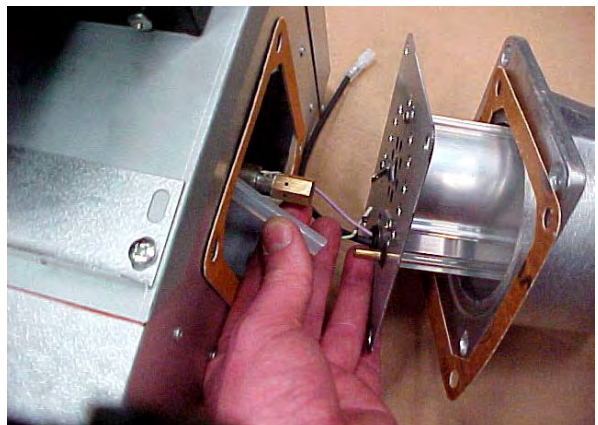

Step 6 Detach the two screws holding the front of the gas valve.

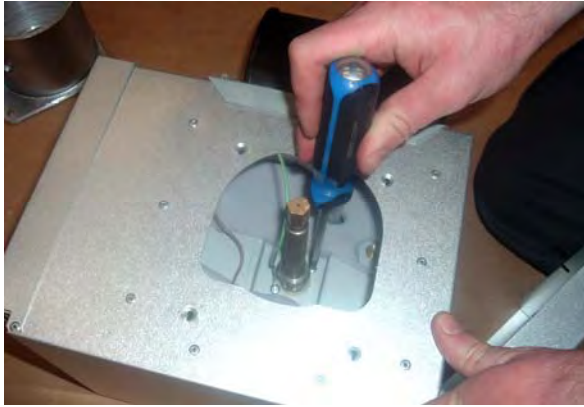

Step 7 Remove the four screws holding the rear burner plate in position plus the two screws from the gas valve flange.



Step 11 The gas valve can now be replaced.

Step 12 Refit all components in reverse order.

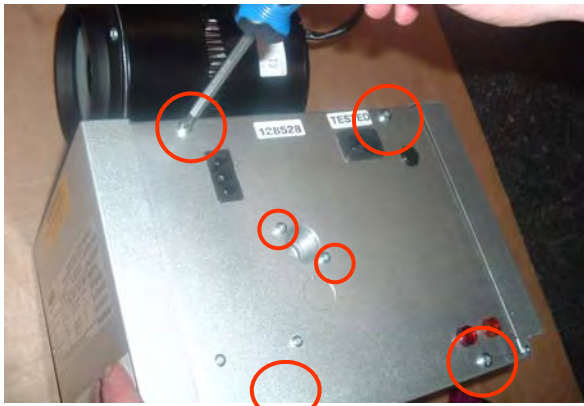

Step 8 Remove the rear plate.

Step 13 (For Natural Gas burners ONLY). Ensure step screw is in the correct position as indicated in the diagram below.

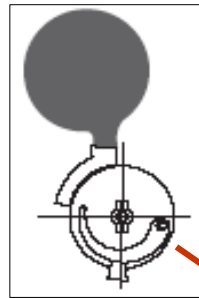

Step 14 Set gas pressures to data badge or as per section 1.11 and ensure reliable burner performance.



Step 9 The jet carrier, gas inlet, and wiring harness can now be detached from the gas valve.

Step 15 Test product and close access doors.

Step 10 The two screws retaining the gas valve can then be removed.

8. User & Operating Instructions.

8.1 To Start the Heater

1. Ensure gas supply is turned on.
2. Electrical supply to the controls is on.
3. Ensure that the controls are correctly set i.e.;

 - Clock is correctly set.
 - Heater program is correctly set.
 - Required room temp is correctly set

4. Once the heating controller 'calls for heat' power will be supplied to the heater(s). The red neon will then illuminate.
5. After a pre-purge period of 10 seconds the burner will ignite and the amber neon will then illuminate.
6. If lockout occurs press the lockout reset button (if available), or switch off electrical supply and restart after 15 seconds.
7. If lockout occurs three times consecutively switch off and isolate the gas and electricity supplies.

Contact the AmbiRad Service department.

8.2 To Switch Off Heater

1. Switch off electrical supply to the heater. The burner will stop and the fan will shut off.
2. If the heater is to be switched off for periods in excess of one week it is highly recommended that both the gas and the electrical supplies are turned off.

8.3 Routine Maintenance between Service Intervals

After ensuring that the heater is cold and mains electric isolated, cleaning of the reflectors with a soft cloth and a mild detergent (non solvent based cleaners only) in water can be undertaken.

Additional removal of dust from the radiant tubes, burner and heat exchanger can be undertaken.

8.4 Frequency of Servicing

The manufacturer recommends that to ensure continued efficient and safe operation of the appliance, the heater is serviced annually by a competent person e.g. every year in normal working conditions but in exceptional dusty or polluted conditions more frequent servicing may be required.

The manufacturer offers a maintenance service.

Details are available on request.

For Service requirements, please contact AmbiRad.

For further technical and service support visit our Support Information Database at www.s-i-d.co.uk



AmbiRad Limited Fens Pool Avenue
Brierley Hill West Midlands DY5 1QA
United Kingdom.

Telephone 01384 489700

Facsimile 01384 489707

Email info@ambirad.co.uk

Website www.ambirad.co.uk

Technical Support www.s-i-d.co.uk

AMBI RAD
ENERGY EFFICIENT HEATING SYSTEMS

AmbiRad is a registered trademark of AmbiRad Limited. Because of continuous product innovation, AmbiRad reserve the right to change product specification without due notice