



















SMARTCOM³ v2a CONTROL PANEL INSTALLATION AND USER MANUAL.

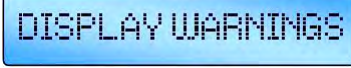

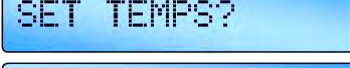
QUICK GUIDE

	Page		Page
 PLUS	Increase a value9	 FAN ONLY	Initiate a period of fan only18
 MINUS	Decrease a value9	 OVERTIME	Initiate a period of heating18
 OK	Accept a value9	 HOLIDAY	Initiate a holiday period18
 UNDO	Cancel a value or a mode9	 CHECK TEMP	Toggle the temperature display 18
 SETTINGS	Initialise programming10	 LOCKOUT	Clear a flame failure lockout19
11	17
12	19
14	21
15	22
16		

INDEX

Section

Technical Specifications

1.1 Operating Environment	3
1.2 Performance Specifications	3
1.3 SC3FM Facia Mount Electrical Specifications	3
1.4 SC3SZ Single Zone Electrical Specifications	3
1.5 SC3MZ Multi Zone Electrical Specifications	3

Installation Instructions

2.1 Mounting the Control Assembly	4
2.2 General Wiring Specifications	5
2.3 SC3FM Version Wiring Connections	6
2.4 SC3SZ Version Wiring Connections	7
2.5 SC3MZ Version Wiring Connections	8

Operating Instructions

3.1 Factory default settings	9
3.2 The Buttons	9
3.3 The Settings button	10
3.4 Setting the clock	11
3.5 Setting the Program (on/off times)	12
3.5.1 Copying the Programs	13
3.6 Setting the Modes	14
3.7 Setting day and night temperatures	15
3.8 Setting the system OFF	16
3.9 Optional Passwords	17
3.10 Checking the temperature	18
3.11 Setting a temporary Holiday period	18
3.12 Setting a temporary Overtime extension period	18
3.13 Setting a temporary Vent period	18
3.14 Display messages	19
3.14.1 Error message:- Lockout	19
3.14.2 Exam period	19
3.14.3 Optimum Start and Optimum Stop	19
3.14.4 Service hours	19
3.14.5 External Sensor fault indication	19
3.14.6 External Inputs	20
3.14.6.1 External Input priority	20
3.15 Network Controllers	21
3.15.1 Operating the Master	21

Engineer Functions

4.1 Introduction	22
4.2 Settings	22
4.3 The Engineer Variables	23

Battery Cell information

5.1 Battery replacement	26
5.2 Battery specification	26

Introduction

In order to satisfy the increasing need for higher efficiencies and to complement the development of efficient heating systems AmbiRad Group have upgraded their 'SmartCom' range of controllers.

With a new larger, back lit screen and simpler to operate with intuitive programming, SmartCom³ provides cost effective energy for small single heater installations through to large

multi-zone applications requiring centralised control. This operating manual gives simple step by step instructions for both the end user and commissioning engineer alike.

 This control must be installed according to the current IEE Wiring Regulations and should include full disconnection means and fusing appropriate to the connected loads.

1 Technical Specifications.

1.1 Operating Environment

- Operating temperature range: 0° C to 40° C
- Operating humidity range: 0 to 90% RH.
- Control IP rating: IP30
- Pollution degree: II environment
- Control safety construction: class II
- Mains supply: 230Vac nominal, 200Vac to 253Vac actual, 50Hz.
- On board supply fuse: 1AT
- Rated impulse voltage: 2500V

1.2 Performance Specifications

- Operation is by Class A software and Type 2 action. Version 2a
- The mains supply to the electronic circuit is protected by a time delay fuse.
- Flame failure input: 230Vac nominal, 200Vac to 253Vac actual, 50Hz. Presence of voltage indicates flame failure.
- The burner reset output is either volt free or Live/Neutral (selected by a plug-in jumper) note: Live only - SC3 FM version.
- Remote volt-free switch outputs will be 24Vdc/5mA
- The built-in room temperature sensor has a measuring range of 0° C to 30° C with a resolution of 0.2° C.
- Temperature sensor readings can be offset to allow for errors due to sensor tolerances and location. NB Frost protection readings are also affected by offsets.

Built-in and remote room temperature sensor.

Measuring range:	0 – 30° C.
Resolution:	0.2° C.
Untrimmed accuracy over range:	+/- 1.4° C.
Accuracy over range with offset:	+/- 0.6° C.

Unless well ventilated, heat generated in the controller may cause the built-in sensor to over-read temperatures.

Remote duct temperature sensor.

Measuring range:	10 – 60° C.
Resolution:	0.2° C.
Accuracy over range:	+/- 3.0° C.

1.3 SC3 FM Electrical Specifications.

Burner reset, Heat and Vent 1 relay rating:	7A/240Vac resistive 2A/240Vac inductive
Power consumption:	2.5W

1.4 SC3 SZ Electrical Specifications

Burner reset, Heat and Time relay rating:	7A/240Vac resistive 2A/240Vac inductive
550W Vent 1 relay rating:	10A/240Vac resistive 3A/240Vac inductive, (550W single phase motor, max)
Power consumption:	2.5W

1.5 SC3 MZ Electrical Specifications

All relays except Vent 1 rating:	10A/240Vac resistive 2A/240Vac inductive
Vent 1 relay rating	10A/240Vac resistive 3A/240Vac inductive, (550W single phase motor, max)
Power consumption:	5W
Communications wiring:	5W Screened twisted pair Daisy-chain configuration. Belden 9841 (or equiv) recommended. Max length = 500m
0 – 10V signals	Output impedance = 500 Ohm. Max current drive capacity = 5mA

The power supply is SELV isolated, therefore low voltage wiring to the control does not need to be mains level rated.

2 Installation instructions.

2.1 Mounting the Control Assembly

The housing consists of a two part plastic moulding held together by four screws.

- Remove the screws.
- Carefully lift the lid and unplug the ribbon cable from the power PCB assembly situated in the bottom of the case.
- A drilling template is provided to enable the controller assembly to be securely fixed to a solid surface.
- It is recommended that the controller is installed no less than 1.5m above the floor level.
- The lid with display and connecting ribbon cable can be rotated through 180° therefore allowing the controller to be positioned with the cable entry to the bottom or the top depending on the cable routing.
- Do not mount the controller on an excessively warm or cold surface or where it could be affected by direct sunlight or other heat/cool sources.
- The mounting surface should be non-conducting or earth bonded and should prevent access to the rear of the control.

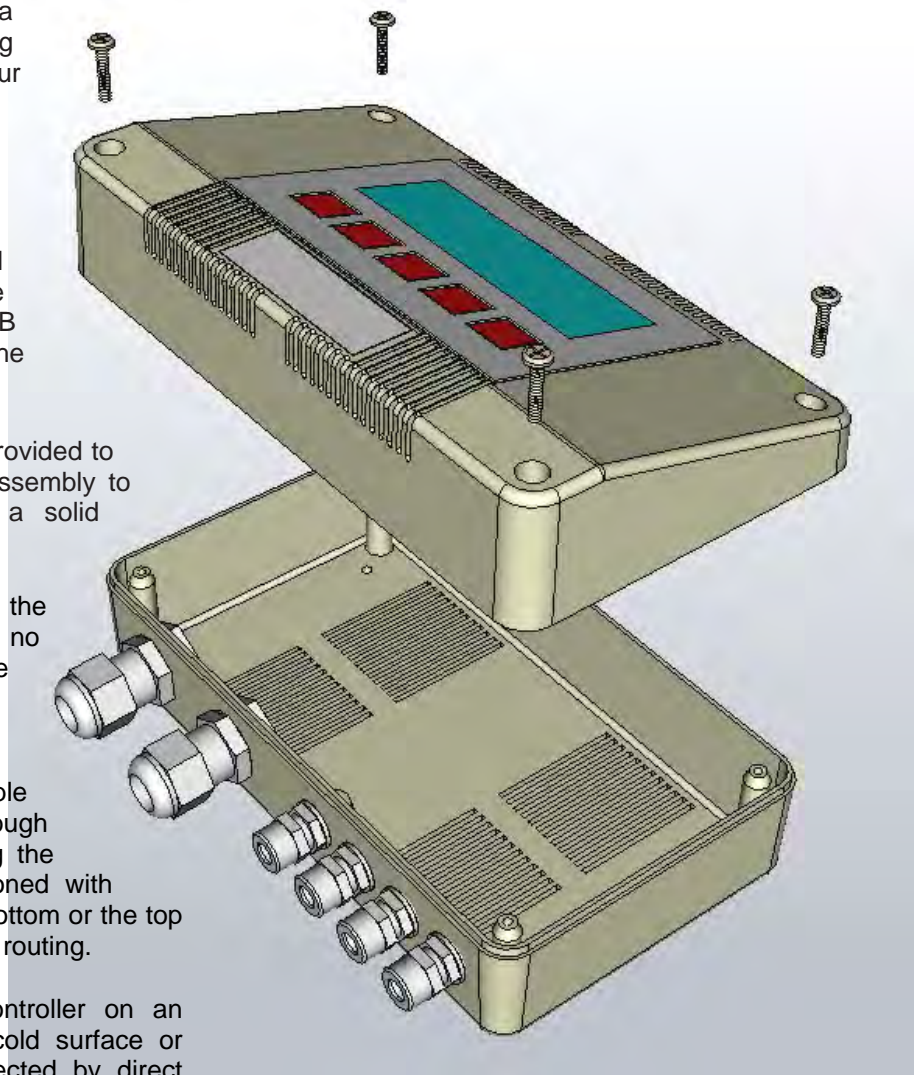

Note: The recommended minimum mounting height only applies when the internal sensor is used.

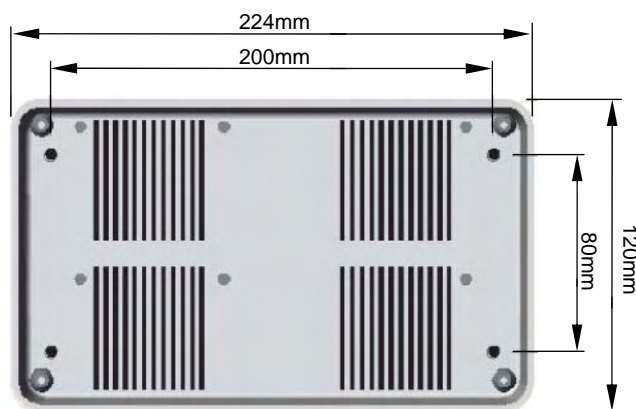
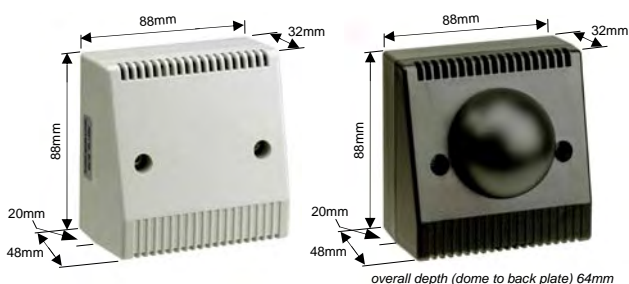

Dimensional details

Note: when used in dusty/contaminated environments it may be necessary to locate the SmartCom panel within an enclosure (or locate panel remotely) and use an external temperature sensor.

Please refer to the following wiring connection drawings and observe the note at the bottom of each page referring to cable type and length.

2.2 General Wiring Specifications

! All wiring connections must be made by a suitably qualified person.

When making connections to screw terminals please ensure that no more than 6mm of insulation is stripped back and that no stray wire strands escape.

Complete installation wiring instruction booklets are supplied to suit individual heating applications which can also be downloaded from our support databases by going to our websites www.s-i-d.co.uk or <http://support.bensonheating.co.uk>

It is important to read both the product instructions and these control instructions to ensure satisfactory operation.

Failure to follow these guidelines may result in electrical interference or unsatisfactory operation.



2.3 SC3FM WIRING CONNECTIONS

Warning
 All external wiring **MUST** comply with the current IEE wiring regulations.

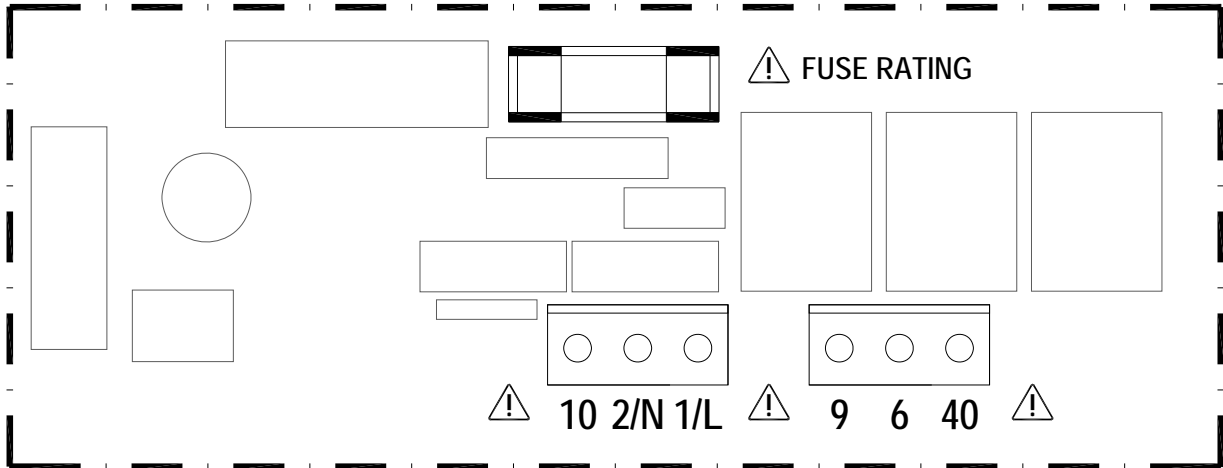

Terminal No.	Connection	Capacity mm ²
10	Flame failure input (230V)	2.5
2/N	Neutral supply input	2.5
1/L	Live supply input	2.5
9	Burner reset output	2.5
6	Heat 1 relay output (1 stage)	2.5
40	Vent 1 relay output (550W/low fan)	2.5

2.4 SC3SZ WIRING CONNECTIONS

Warning
All external wiring **MUST** comply with the current IEE wiring regulations.

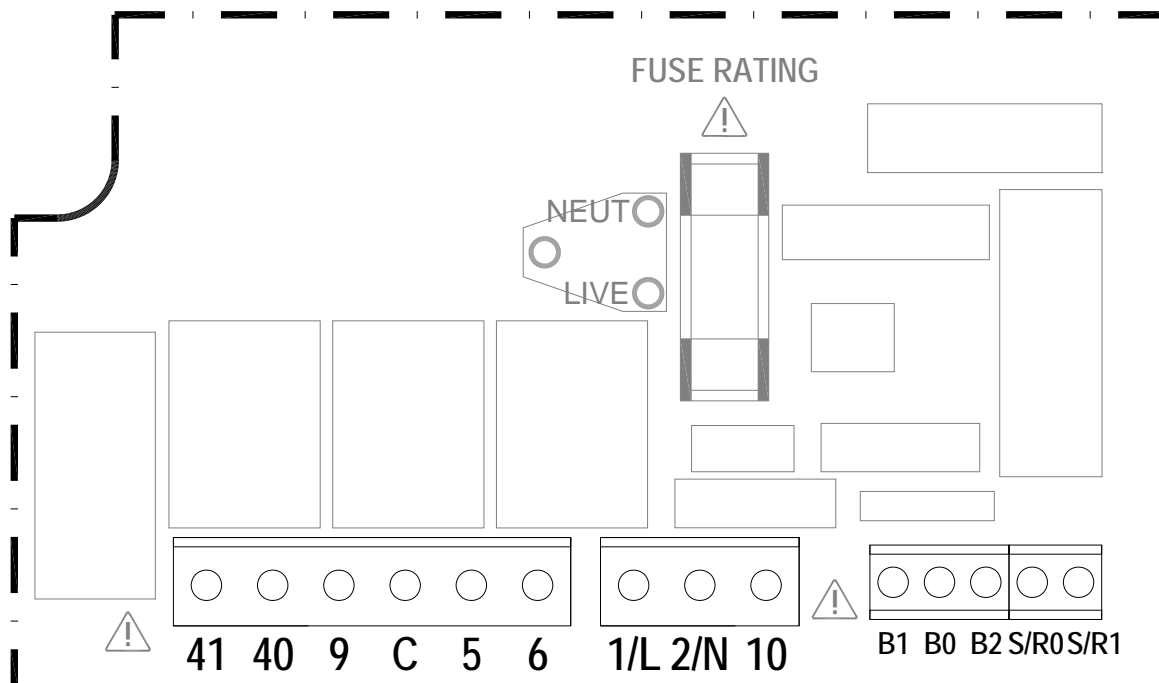

Terminal No.	Connection	Capacity mm ²
41	Vent 1 relay input (550W/low fan)	2.5
40	Vent 1 relay output (550W/low fan)	2.5
9	Burner reset output	2.5
C	Flame failure input (volt free)	2.5
5	Time relay output	2.5
6	Heat 1 relay output (1 stage)	2.5
1/L	Live supply input	2.5
2/N	Neutral supply input	2.5
10	Flame failure input (230V)	2.5
B1	Remote ON input (e.g. BMS time signal)	1.5
B0	Remote common (e.g. output to BMS/interlock)	1.5
B2	Remote OFF input (e.g. door interlock)	1.5
S/R0	Remote room temperature sensor	1.5
S/R1	Remote room temperature sensor	1.5

A terminal block is supplied to enable multiple connections to B0/B2 as detailed in product wiring connections.

Remote switch inputs should be connected by 6A mains* cable of maximum length 100m. The optional remote temperature sensor may be placed at a distance of up to 100m (maximum)

from the control unit, using screened 6A mains* cable. Connect the screen to terminal B0.

All sensor and signal wiring should be kept separate from mains wiring to minimise noise pick-up.

*The power supply is non-isolated, therefore all wiring to the control must be mains rated.

2.5 SC3MZ WIRING CONNECTIONS

Warning
All external wiring MUST comply with the current IEE wiring regulations.

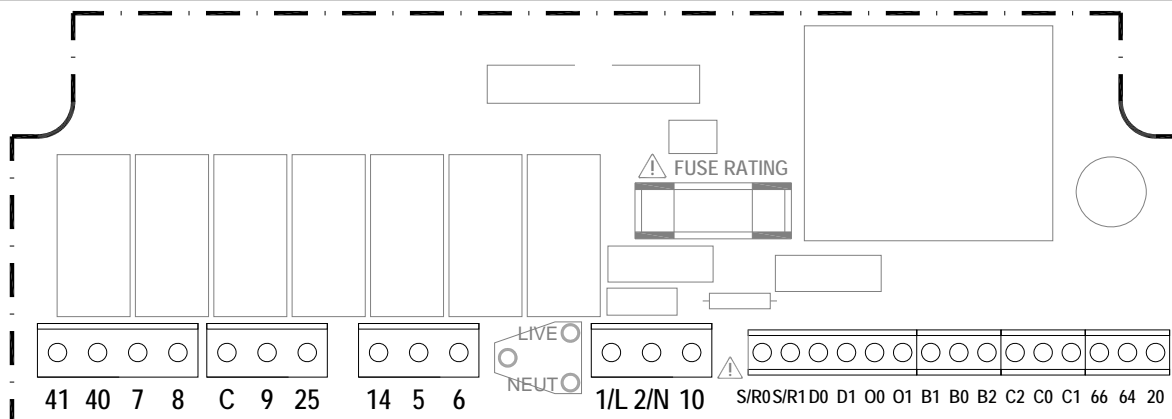

Terminal No.	Connection	Capacity mm ²
41	Vent 1 relay input (550W/low fan)	2.5
40	Vent 1 relay output (550W/low fan)	2.5
7	Heat 2 relay input (2 stage)	2.5
8	Heat 2 relay output (2 stage)	2.5
C	Flame failure input (volt free)	2.5
9	Burner reset output	2.5
25	Vent 3 relay output (damper)	2.5
14	Vent 2 relay output (high fan)	2.5
5	Time relay output	2.5
6	Heat 1 relay output (1 stage)	2.5
1/L	Live supply input	2.5
2/N	Neutral supply input	2.5
10	Flame failure input (230V)	2.5
S/R0	Remote room temperature sensor	1.5
S/R1	Remote room temperature sensor	1.5
D0	Remote duct temperature sensor	1.5
D1	Remote duct temperature sensor	1.5
O0	Outside air temperature sensor	1.5
O1	Outside air temperature sensor	1.5
B1	Remote ON input (e.g. BMS time signal)	1.5
B0	Remote common (e.g. output to BMS/interlock)	1.5
B2	Remote OFF input (e.g. door interlock)	1.5
C2	Communication output (Networking)	1.5
C0	Communication ground (Networking)	1.5
C1	Communication input (Networking)	1.5
66	Channel 1, 0~10V burner output (GM44)	1.5
64	Channel 1 and 2 common (-V) output	1.5
20	Channel 2, 0~10V damper output	1.5

A terminal block is supplied to enable multiple connections to B0/B2 as detailed in product wiring connections. 0-10V outputs and remote switch inputs should be connected by 0.75mm² cable of maximum length 100m. The remote temperature sensor may be placed at a distance of up to 100m (maximum) from the control unit, using screened 0.75mm² cable to

improve noise rejection. Connect the screen to terminal B0. Master-slave communication is by screened twisted pair cable, RS 485 compatible, such as Belden 9841 (or Equiv). Maximum overall system length is 500m. Connect screens to B0 and C0. All sensor and signal wiring should be kept separate from mains wiring to minimise noise pick-up.

3 Operating instructions.

3.1 Factory default settings

For speedy installation and ease of first operation, the SmartCom³ is supplied from the factory with pre-programmed default settings.

These are:

On / Day temperature 18°C
 Off / Night temperature 5°C
 ON time 08:00 Mon thru Fri

OFF time 16:30 Mon thro Fri
(no further ON/OFF times set or weekends)
 Program mode Auto
 Control type Warm Air*
 Sensor type Internal*
 Night setback On*
 Frost protection On*
 Networking Off*
 Pin protection Off*

** can be altered within Engineers settings if required.*

3.2 The Buttons





The ten buttons have the following functions:

-  Press the + button to increase a value.
-  Press the - button to decrease a value.
-  Press the OK button to accept the value and advance to the next display.
-  Press to cancel overtime, vent, exam*, OFF and holiday modes or to cancel a setting but save any previous changes.
-  Initialise and step through programming modes.
-  Pressing the FAN ONLY button will force the controller to operate Vent 1 relay regardless of the room temperature while Heat relays are disabled. Pressing the UNDO button, at any time will cancel this operation.
-  Pressing the OVERTIME button in an OFF period will initiate or extend the day-time operation of the controller.

Pressing the UNDO button, at any time will cancel this operation.

-  The controller can operate in holiday mode, with frost protection for a number of days. When the holiday period expires the controller returns to normal operation. Pressing the UNDO button, at any time will cancel this operation.

-  Pressing the CHECK TEMP button will display the sensor (room) temperature on the first press and the set (program) temperature on the second press. The third press will return the display to normal.

-  Pressing the LOCKOUT button will clear a flame failure lockout. In order to reset the lockout, press and release the LOCKOUT button. After 10 seconds the controller will return to normal operation. The lockout warning and LED will continue to display if the flame failure signal is cleared at source.

Note:

If no keypad action takes place for 60 seconds, the current selection is cancelled and the display returns to day and time and previously set operating mode.

** Exam Heating mode (EH) will appear only if selected in the engineer functions.*

3.3 The SETTINGS button





Pressing the SETTING button will scroll through the user options in the following sequence. Repeated pressing of this button will loop these options round to the start.

 Allows the user to set the hour, minute, day, month and year.

 Allows the user to set up to 3 time period per day. Automatic copy function available.

 Allows the user to set the operating relevant mode to the application.

 Allows the user to set day and night temperatures.

 Allows the user to switch all functions to an OFF status.

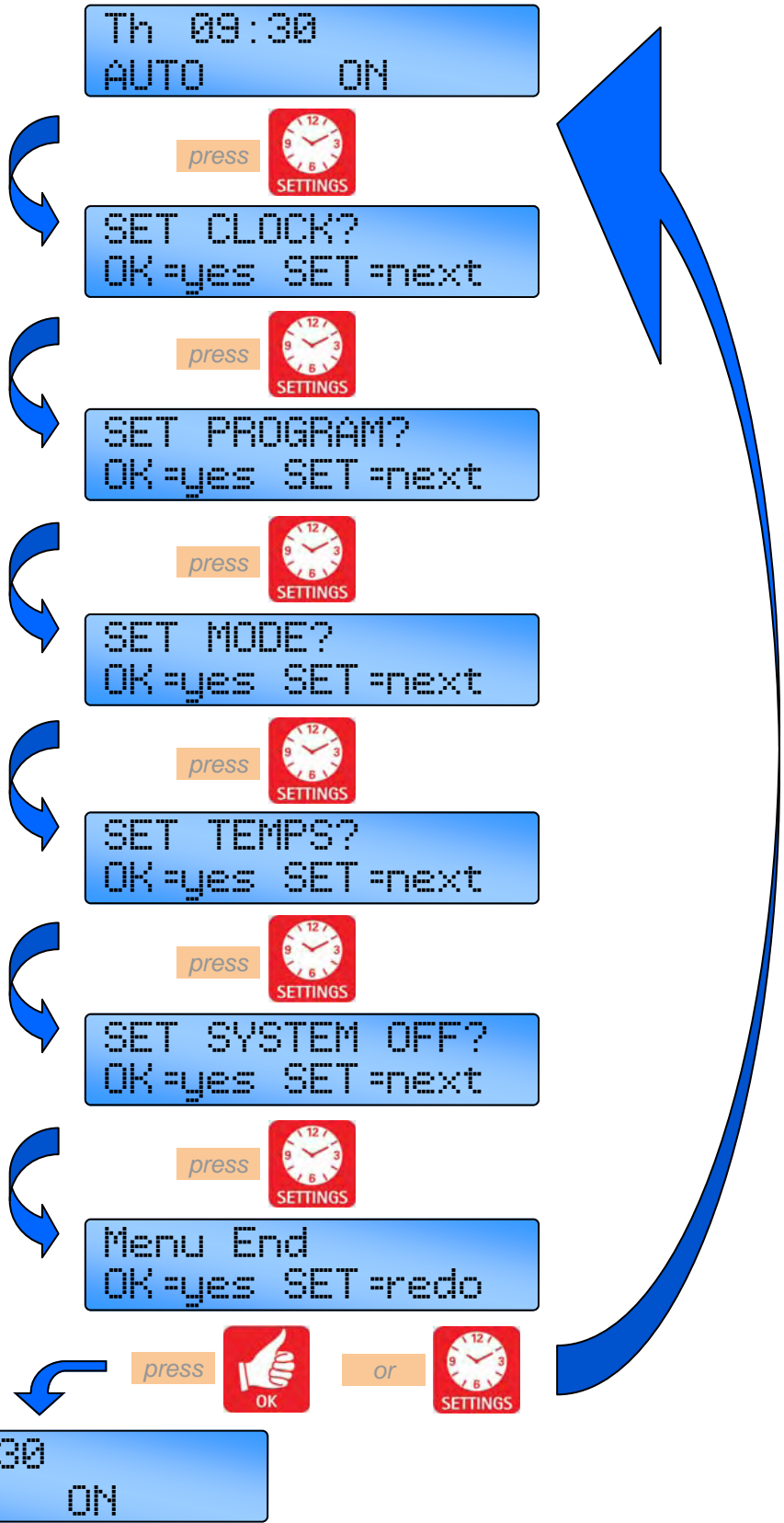

Th 09:30
AUTO ON

3.4 Setting the Clock



Press the **SETTING** button till SET CLOCK? appears in the display.



Press the **OK** button to change this user mode.

Value to alter/confirm will start flashing.

SET CLOCK?
OK=yes SET=next



SET Day Mo 09:29
+ or - then OK

SET PROGRAM?
OK=yes SET=next

follow 'Setting the PROGRAM' menu

SET Hrs Mo 09:29
+ or - then OK

Rapid advance of a time is achieved by pressing and holding of the button.

SET Mns Mo 09:29
+ or - then OK

SET Dat 18-06-09
+ or - then OK

Clock will automatically compensate between British Summer Time (BST) and Greenwich Mean Time (GMT)

SET Mon 18-06-09
+ or - then OK

SET Yr 18-06-09
+ or - then OK

Menu End
OK=yes SET=redo



Th 09:29
AUTO ON

SET Day Mo 09:29
+ or - then OK

repeat above procedure



Use the + button to increase the value.



Press the **OK** button to accept the value and advance to the next display.



Use the - button to decrease the value.



Press the **UNDO** button to cancel setting but save any previous changes.

3.5 Setting the Programs



Press the **SETTINGS** button till **SET PROGRAM?** appears in the display.



Press the **OK** button to change this user mode.

Value to alter/confirm will start flashing.

press  or 

```

SET PROGRAM?
OK=yes SET=next
    
```

 3 timeslots per day (each timeslot includes an on and off time) are allowed.

```

SET Day Mo
+ or - then OK
    
```

```

SET MODE?
OK=yes SET=next
    
```

follow 'Setting the MODE' menu

```

Mo ON 1 08:00
+ or - then OK
    
```

```

Mo OFF 1 16:30
+ or - then OK
    
```

```

Mo ON 2 --:--
+ or - then OK
    
```

 Rapid advance of a time is achieved by pressing and holding of the button.

 If the **-** button is pressed at an unused time slot "--:--", the screen advances to a further ON time. The new ON time will start flashing.

press 

or 

```

Mo ON 2 17:30
+ or - then OK
    
```

```

Copy to Tu
OK=yes SET=next
    
```

follow copy function menu

```

Mo OFF 2 20:00
+ or - then OK
    
```

```

Mo ON 3 --:--
+ or - then OK
    
```

 Pressing the **OK** button at an unused time slot "--:--", will display the automatic copy function. (see next page). Press **OK** to copy day settings. Press **SETTINGS** to alter times for specific days.

press 

or 

```

Mo ON 3 20:30
+ or - then OK
    
```

```

Copy to Tu
OK=yes SET=next
    
```

follow copy function menu

```

Mo OFF 3 22:00
+ or - then OK
    
```

```

Copy to Tu
OK=yes SET=next
    
```

follow copy function menu



Use the **+** button to increase the value in 1 minute steps.



Press the **OK** button to accept the value and advance to the next display.



Use the **-** button to decrease the value. the value in 1minute steps.



Press the **UNDO** button to cancel setting but save any previous changes.

Setting the Programcont.

3.5.1 Copy Function



Press the SETTING button till SET PROGRAM? appears in the display.



Press the OK button to change this user mode.

Value to alter/confirm will start flashing.

Copy to Tu
OK=yes SET=next



Press OK to copy day settings. Press SETTINGS to alter times for that day. (follow previous page)

Copy to We
OK=yes SET=next

SET Day Tu
+ or - then OK

follow 'Setting the PROGRAM' menu

Copy to Th
OK=yes SET=next

Copy to Fr
OK=yes SET=next

Copy to Sa
OK=yes SET=next

Copy to Su
OK=yes SET=next

MENU END
OK=yes SET=redo



Th 09:40
AUTO ON

SET Day Mo
+ or - then OK

follow PROGRAM menu



Use the + button to increase the value.



Press the OK button to accept the value and advance to the next display.



Use the - button to decrease the value.



Press the UNDO button to cancel setting but save any previous changes.

3.6 Setting the Mode



Press the **SETTINGS** button till SET MODE? appears in the display.



Press the **OK** button to change this user mode.

SET MODE?
OK=yes SET=next

press



or



SET AUTO MODE?
OK=yes SET=next

SET TEMPS?
OK=yes SET=next

follow 'Setting the MODE' menu



Press **SETTINGS** to advance to the next mode to choose. Press **OK** to accept new mode.

Auto mode: Heating and ventilation operate automatically depending on the room temperature, time/set temperature program and the control method selected. Ventilation is disabled during off periods of the time program.

Frost Only mode: Heating operates automatically depending on the room temperature and control method selected. The set temperature is fixed at 5°C. Ventilation is disabled.

Fan Only mode: Ventilation operates automatically depending on the room temperature, time/set temperature program and the control method selected. Heating is disabled. Ventilation is disabled during off periods of the time program.

press



SET EXAM MODE?
OK=yes SET=next

SET FROST ONLY?
OK=yes SET=next

SET HEAT ONLY?
OK=yes SET=next

SET FAN ONLY?
OK=yes SET=next

Menu End
OK=yes SET=redo

press



or



Th 09:30
HEAT ON

SET AUTO MODE?
OK=yes SET=next

repeat procedure above



Exam Heating mode:

If the control is used on a system installed in a sports hall, a temporary increase in temperature can be set to improve comfort for people sitting in the building. Heating will be controlled to "temperature 2". Exam Heating mode can only be set during an ON period and will last only until the next OFF period unless cancelled by the **UNDO** button.

Heat Only mode: Heating operates automatically depending on the room temperature, time/set temperature program and the control method selected. Ventilation is disabled.



Pressing **SETTINGS** at 'Menu End' will scroll round back to the first mode setting.



Use the **SET** button to advance to the next display.



Press the **UNDO** button to cancel setting but save any previous changes.



Press the **OK** button to accept the value and advance to the next display.

3.7 Setting the Day and Night Temps



Press the **SETTINGS** button till SET TEMP? appears in the display.



Press the **OK** button to change this user mode.

Value to alter/confirm will start flashing.

SET TEMPS?
OK=yes SET=next

press



or



DAY TEMP 16.0 °C
+ or - then OK

SET SYSTEM OFF?
OK=yes SET=next

follow 'SYSTEM OFF' menu

* EXAM TEMP 18.0 °C
+ or - then OK

NITE TEMP 5.0 °C
+ or - then OK

Menu End
OK=yes SET=REDO

press



or



Th 09:30
AUTO ON

DAY TEMP 18.0 °C
+ or - then OK

repeat above procedure

 If the control is used on a system installed in a sports hall, a temporary increase in temperature can be set to improve comfort for people sitting in the building. Heating will be controlled to "temperature 2".

Exam Heating mode can only be set during an ON period and will last only until the next OFF period unless cancelled by the UNDO button.



* *Note: Exam heating mode will only appear if selected in the engineers functions.*



Use the + button to increase the value.



Press the **OK** button to accept the value and advance to the next display.





Use the - button to decrease the value.



Press the **UNDO** button to cancel setting but save any previous changes.

3.8 Setting the System OFF

 Press the SETTING button till SET SYSTEM OFF? appears in the display.

 Press the OK button to change this user mode.

Value to alter/confirm will start flashing.

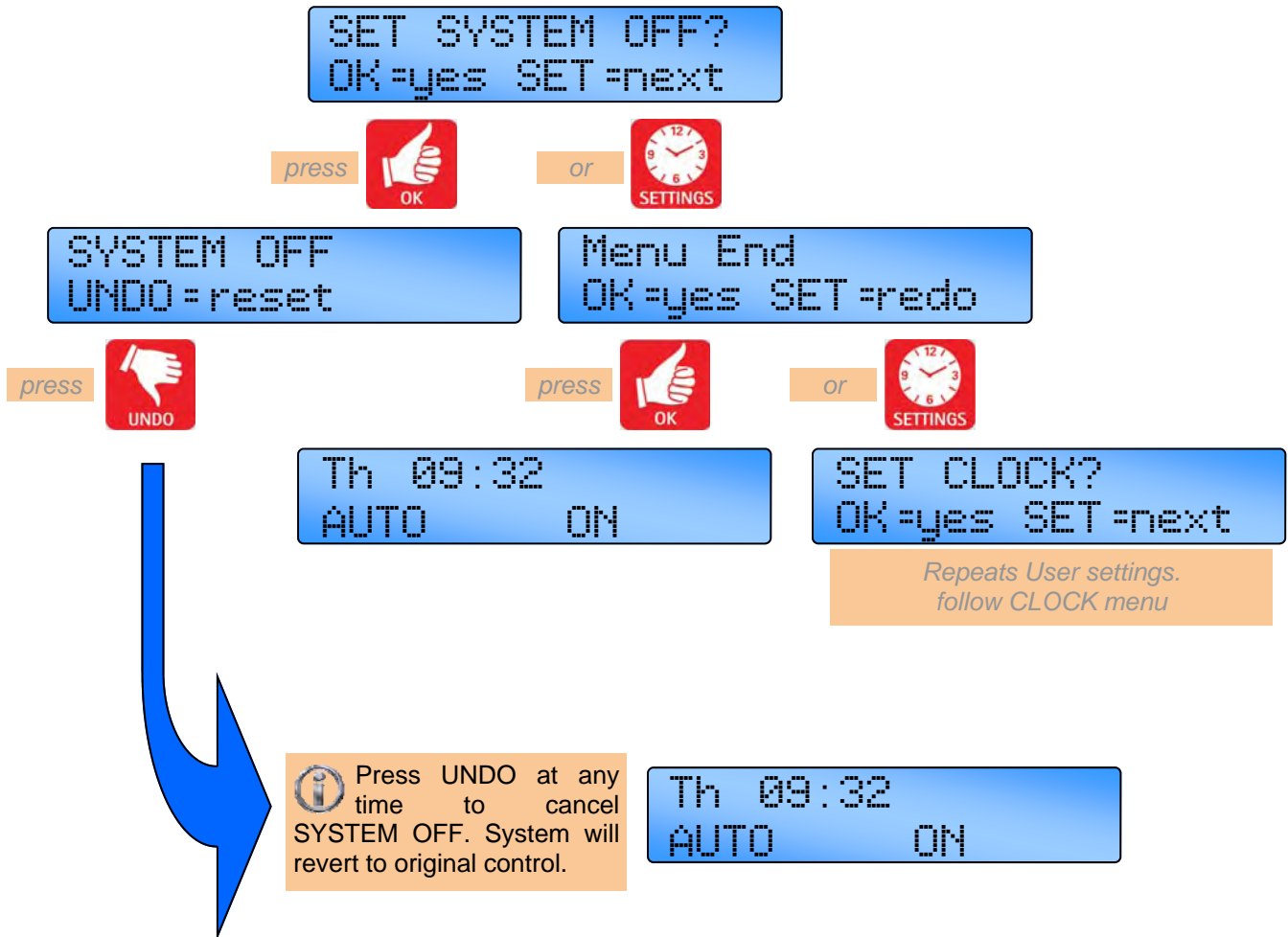

 Use the SET button to advance to the next display.

 Press the UNDO button to cancel setting and revert to original control.

 Press the OK button to accept the value and advance to the next display.

3.9 Optional Password (PIN protection)

To protect the entered settings, you can use a password PIN code. This unique 4 digit PIN code will be required to change the settings that you have stored and will prevent unauthorised amendment of the settings.



 PIN protection will only take effect 30 seconds after the last button was pressed

Refer to the Engineers Settings of this manual to activate this option.

Note: PIN protection is not initiated as a default setting.

 Press + or - button to set the first number then press the OK button. The next digit will start flashing to be set. Continue till last number is entered. The final press of the OK button will allow settings to be modified.

PIN 3254 shown opposite is an example only.



 * If you forget the PIN code there is a Master PIN code that is factory set by the manufacturer. This Master PIN code over-rides the unique PIN code and will enable you to change the PIN code again. Please call the manufacturer for this Master PIN code.



Use the + button to increase the value.



Press the OK button to accept the value and advance to the next display.



Use the - button to decrease the value. the value.



Press the UNDO button to cancel setting but save any previous changes.

3.10 Checking the temperature



Pressing the CHECK TEMP button will display the sensor (room) temperature on the first press and the set (program) temperature on the second press. The third press will display the *outside temperature if set within engineer settings or return the display to normal.

NB. The display will return to normal 10 seconds after the second press if CHECK TEMP is not again.

ROOM TEMP 16.6 °C

SET TEMP 18.0 °C

* O/S TEMP 30.0 °C

Pressing the CHECK TEMP and the + button together will display the duct temperature (if fitted) . The display will return to normal after 10 seconds if not cancelled by UNDO.

3.11 Setting a temporary Holiday period



The controller can operate in holiday mode, with frost protection, for a number of days. The holiday mode is set as follows:

Press the HOLIDAY button. 'HOLIDAY' will be displayed and the number of days will flash.

HOLIDAY 0 days
+/- /OK

Press the + or – button to increase or decrease the number of holiday days. (Values from 00 to 31 are acceptable). Zeros '00' indicates no holiday period set.

HOLIDAY 7 days
+/- /OK

Press the OK button to accept the holiday setting. 'HOLIDAY SET' will be shown along with the normal display until the start of the holiday period.

Fr 16:58
HOLIDAY SET

The holiday period will start at midnight on the day that it is initiated. From then on the 'HOLIDAY' along with the remaining number of days will be displayed. When the holiday period expires the controller returns to normal operation.

Pressing the UNDO button, at any time will cancel the holiday period.

3.12 Setting an overtime extension period



Pressing the OVERTIME button in an OFF period will initiate or extend the day-time operation of the controller. Overtime is activated as follows:

Press the OVERTIME button. 'OVERTIME' will be displayed and the hours and minutes digits will flash.

OVERTIME 00:00
+/- /OK

Press the + or – buttons to increase or decrease the required amount of time in 10 minute increments. (Values between 0 and 60 minutes are acceptable by default. The range can be extended up to 10 hours in the Engineer Functions).

OVERTIME 02:00
+/- /OK

Press OK to accept the setting. The display will show the overtime minutes remaining. When the overtime period expires the controller returns to normal operation.

OVERTIME 01:59
UNDO = reset

Pressing the UNDO button, at any time will cancel this operation.

3.13 Setting a temporary Fan period



Pressing the FAN ONLY button will force the controller to operate Vent 1 relay regardless of the room temperature while Heat 1 and Heat 2 relays are disabled and Vent 2 and Vent 3 relays operate according to the room temperature. The FAN ONLY period is activated as follows:

Press the FAN ONLY button. 'FAN ONLY' will be displayed and the hours and minutes digits will flash.



Press the + or – buttons to increase or decrease the required amount of time in 10 minute increments. (Values between 0 and 60 minutes are acceptable by default. The range can be extended up to 10 hours in the Engineer Functions).



Press OK to accept the setting. The display will show the overtime minutes remaining. When the overtime period expires the controller returns to normal operation.

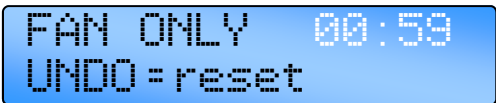

Pressing the UNDO button, at any time will cancel this operation.

3.14 Display Messages.

3.14.1 Lockout Error

When the controller detects a flame failure signal, the screen will show a LOCKOUT display and the red LED will illuminate.



The lockout warning and LED will continue to display if the flame failure signal is cleared at source.

In order to reset the lockout, press and release the LOCKOUT button. After 10 seconds the controller will return to normal operation.

NB. The lockout will not be displayed for the first 45 seconds after initial burner start. Fan and heating outputs will continue to function normally despite the lockout condition.

3.14.2 Exam period

If the control is used on a system installed in a sports hall, a temporary increase in temperature can be set to improve comfort for people sitting in the building. The screen will show an EXAM MODE display.



This warning will continue to display until the next time switch or until the undo button is pressed.

3.14.3 Optimum Start and Optimum Stop.

This feature is factory set. If not required, refer to the Engineer Functions. Optimum start is an energy saving feature which turns the heating system on at the latest possible time, whilst ensuring that the desired temperature is achieved at the ON time.

When the controller is optimising, the following is displayed. Ventilation remains disabled during the optimum start period.



Towards the end of a heating period the controller may turn off the heating early.

The optimum stop period is calculated and relates to the speed of response of the building. The optimum stop period is a factor of the optimum start historical information and will be limited to the maximum time period set in the engineer functions. The controller will only allow the temperature to fall by up to 2°C below the set point during this period. Ventilation is disabled during the optimum stop period.

When the controller is optimising, the following is displayed.



3.14.4 Service Hours

The controller has a programmed burner hour limit. This is default at 1200 hours but can be adjusted within the Engineers codes.

Once the heater has reached this set limit, the screen will show A SERVICE HOURS display to register that a service is due.



3.14.5 External sensor fault indication

If an external sensor is used/set within Engineers settings but the sensor is open circuit, the display

will the following error:



3.14.6 External Inputs

There are two external inputs for direct control of the operating mode of the system.

The ON input forces the controller to operate in the on mode for as long as the input is active (switch closed). This could be used for an override on switch or for BMS control.

Note: If the controller is to be used in a BMS system then all of the ON times should be set as unused, then the controller will by default control at off/night temperature. The BMS system can then activate on/day or frost temperature control using the external inputs.



The FROST input forces the controller to operate in the frost mode for as long as the input is active (switch closed). This could be used as a holiday switch or an off switch or as a door interlock to turn the heating off when a door is open or for BMS control.



In addition the remote Frost input can be assigned under engineers menu to act as a multipurpose alarm input, blocked filter alarm input or an air flow failure alarm input with contacts closed for fault condition, open for good condition.

In blocked filter mode the control will display the following warning with the time and operation continuing as normal.



NB. The controller will ignore the input for the first 30 seconds

In air flow failure mode the control will display the following warning with heating operation suspended until a lockout reset operation is performed.



NB. The controller will ignore the input for the first 30 seconds.

As a multipurpose alarm the control will display "REMOTE OFF - CHECK" and the heating operation will be suspended until the fault is corrected.



NB. The controller will ignore the input for the first 30 seconds

Further in a multi-zone system air flow failure on a slave will be displayed on the Master as a lockout with the zone number and lockout reset can be achieved either locally on the affected slave or centrally using the Master controller.

As a multipurpose alarm the input will be effective at all times, whereas in air flow failure and blocked filter modes the controller will ignore the input until 30s from the start of either the heat or time relays as set under the engineers menu.

In a multi-zone system the external inputs to the Master controller will be applied to all zones automatically, however individual zones can be set to ignore the FROST signal from the Master under the engineers menu. The external inputs to a slave controller will apply to that zone only.

3.14.6.1 Priority order of controlling items.

If ON and FROST inputs are both active then the FROST input will take priority.

Where more than one input or setting is trying to operate the control it will respond to inputs in the following priority order:

1. Remote Frost input
2. Overtime (operating with NORMAL/HEAT ONLY/VENT ONLY)
3. Vent mode
4. Holiday
5. Off mode
6. Frost Only
7. Remote On (BMS) input (operating with NORMAL/HEAT ONLY/VENT ONLY)
8. Time program (operating with AUTO/HEAT ONLY/VENT ONLY)

3.15 Network Controllers

With the SmartCom³ MultiZone version up to 16 controllers can be linked together to form a multi-zone heating system. This allows one SmartCom³ (the Master) to communicate with the other controllers (the slaves). The display will state the appropriate zone number.

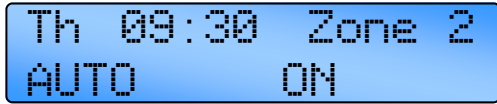

The Master control has the following capabilities:

- Updating the clock on the Master controller will globally update the slave controllers.
- The set program and set temperature functions on the slave controllers can be accessed from the Master controller.
- The room and set temperatures of the slave controllers can be viewed from the Master controller.

- VENT ONLY, HOLIDAY, or OVERTIME buttons on the Master controller are applied to the entire network.
- External inputs to the Master will apply to the entire network.
- Lockouts' on slave controllers will be displayed on the Master controller and can then be cleared on each individual controller or from the Master controller.

The following functions cannot be programmed over the network and must be carried out locally on each slave controller:

- Modes, i.e. HEAT ONLY, AUTO, etc.
- Engineer functions.

Refer to the Engineers Settings of this manual to activate this option.



3.15.1 Operating the Master

When operating the Master controller on a multi-zone system to modify a program or the set program/check temperature, the display will show 'SET Zone' along with the flashing zone number.

Press the + or - button to display the appropriate zone you want to use.



Press OK to accept. The program and temperatures can now be set for that zone.

If a fault occurs in the network or the set up is incorrect, an error message will appear and flash in the Master controller showing the (first) appropriate zone fault.

Once the comms error has been rectified, the display will change to show either a further comms error or back the main screen.



If a lockout occurs within a zone, the Master will display 'Lockout' and the appropriate zone that has the fault.



To reset the lockout, press the LOCKOUT button either on the Master or the Slave controller to that particular zone.



4 Engineers Settings.

4.1 Introduction

The engineer functions allow you to program various advanced parameters.



- All control functions may be optionally password protected by a PIN code.
- Pressing the UNDO button during programming will cause the setting being programmed to be changed back to its original value.
- Pressing the UNDO button twice, consecutively, at any time while in the engineer function, will cause the controller to exit the engineer function and return to normal operation. Only items which have been OK'd will be changed.
- If no keypad action takes place for 60 seconds while in the engineer function, the controller will exit the engineer function and return to normal operation. Only items which have been OK'd will be changed.
- The engineer settings cannot be programmed over the communications link, only on the specific controller.

In order to access the engineer functions:

Press and hold in the  button and at the same time, press the  button.

4.2 Settings

CONTROL TYPE
WARM AIR SET/OK

press  or 

DF & IDF
OFF SET/OK

follow BLUE section - 'WARM AIR' SETTINGS

CONTROL TYPE
WARM AIR +/-/OK

press 

CONTROL TYPE
RADIANT +/-/OK

press 

CONTROL TYPE
RADIANT SET/OK

press 

RAD/NRV/HB SPLIT
ON SET/OK

follow ORANGE section - 'RADIANT' SETTINGS

To aid the on-site engineer, the settings have been arranged by heater type. The default setting is Warm Air. For Radiant, simply alter the control type by using this procedure.

Once the control type has been set, follow the variables as described in their relevant sections in the next procedures.

***SC3-MZ ONLY ***

 Press the SETTINGS button to advance to the next display.

 Press the OK button to alter a setting or accept the a new value.

 Use the + button to toggle between / increase the value.

 Use the - button to toggle between / decrease the value.

 Press the UNDO button to cancel settings but save any previous changes.

ENGINEERS SETTINGS FOR WARM AIR PRODUCTS

ENGINEERS SETTINGS FOR RADIANT PRODUCTS

INTERNAL SENSOR
ON SET/OK

Turn 'ON' for in-built internal sensor.



Can both be set to On to give averaging temperature.

EXTERNAL SENSOR
OFF SET/OK

Turn 'ON' for optional External Black Bulb or Air sensor.

NETWORKING
OFF SET/OK



Up to 16 zones can be networked.

***SC3-MZ ONLY ***

Turn 'ON' for Master and slave configuration.

MASTER UNIT
OFF SET/OK

IF NETWORKING ON

Turn 'ON' for Master control panel.

SLAVE NUMBER
0 SET/OK

FOR SLAVE UNITS ONLY:

Set figure for unique zone number. Max 16.

ZONE TOTAL
0 SET/OK

FOR MASTER UNIT ONLY:

Set figure for total number of ZONES.

SLAVE RESPOND
ON SET/OK

SLAVE UNITS ONLY: Slave responds to remote OFF command from Master control.

SET TIME STEP
1 MIN SET/OK

****IMPORTANT:** Change to '10 MIN' when replacing a V1(a) for a V2(a) Master or Slave.



** SmartCom version will appear during the initial power on.

VENT 3 FUNCTION
FAN SET/OK

Toggle between 'FAN' for warm air and 'DAMPER' for heat/cooling systems.

EXAM MODE
OFF SET/OK

Turn 'ON' for 2 stage temperature in sports halls (i.e. sports/exam modes.)

H-BONE LO/HI
OFF SET/OK

Turn 'ON' for Hi/Lo Herringbone configuration.

MOVE TO TOP OF NEXT PAGE

FROM BOTTOM OF LAST PAGE

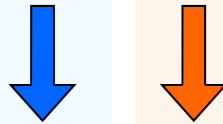

NIGHT SETBACK
ON SET/OK

Turn 'OFF' to deactivate Night Setback (outside of day temperature setting).

FROST PROTECT
ON SET/OK

Turn 'OFF' to deactivate Frost Protection (system off temperature setting 5°C).

LOCKOUT RESET
WARM AIR SET/OK

Toggle between 'WARM AIR' and 'RADIANT' for burner lockout sequence.

LOCKOUT LOG
0 SET/OK

Displays the number of lockouts since last service reset.

LOCKOUT LIMIT
0 SET/OK

Determines the number of lockouts allowed before 'LOCKOUT SERVICE' is displayed.

BURNER LOG
0 Hrs SET/OK

Displays the number of burner hours since last service reset.

BURNER LIMIT
1200 Hrs SET/OK

Determines the number of burner hours allowed before 'SERVICE HOURS' is displayed.

BURNER SAVE LOG
0 Hrs SET/OK

Displays hours saved during ON periods but heating is **not** called for.

BURNER OFF LOG
0 Hrs SET/OK

Displays hours saved during OFF periods but heating **is** required.

T SET BANDWIDTH
2 °C SET/OK

Set control temperature set point Bandwidth. Range 2 to 10°C

Resetting individual logs is achieved by pressing the OK button whilst the log is displayed, then press OK again to accept zero value.

Setting limit to 00 Disables the function.

MOVE TO TOP OF NEXT PAGE



FROM BOTTOM OF LAST PAGE

T SET DEAD BAND
2 °C SET/OK

Set control temperature set point Dead band.
Range 2 to 4°C

SC3-MZ ONLY

DUCT TEMP LOW
2 °C SET/OK

Set duct temperature set point low limit above room temp set point. Range 0 to 20°C

DUCT TEMP HIGH
50 °C SET/OK

SC3-MZ ONLY

Set duct temperature set point high limit.
Range 20 to 60°C

OUTSIDE SENSOR
OFF SET/OK

SC3-MZ ONLY

Turn 'ON' for optional External Air sensor.

HEAT OFF OS TEMP
30 °C SET/OK

SC3-MZ ONLY

Set outside air temperature set point (if turned on above). Range 0 to 30°C

SENSOR OFFSET
0 °C SET/OK

Set space temperature reading offset.
Range -9 to 9°C

OVERTIME MAXIMUM
1 Hrs SET/OK

Set overtime maximum allowed.
Range 0 to 10hrs.

FAN DELAY
30 Secs SET/OK

Set Radiant / NRV / Herringbone fan delay time. Range 0 to 240secs

POST PURGE
120 Secs SET/OK

Set Radiant / NRV / Herringbone post purge fan time. Range 0 to 240secs

VENT MAXIMUM
1 Hrs SET/OK

Set vent mode maximum allowed.

OPTIMUM START
60 Mins SET/OK

Set optimum start time.
Range 0 to 240mins

FROM BOTTOM OF LAST PAGE

OPTIMUM STOP
30 Mins SET/OK

Set optimum stop time.
Range 0 to 120mins

B2=FROST/DOOR
ON SET/OK

Set input B2 to Remote Frost/Door Interlock input.

B2=FILTER/HEAT
OFF SET/OK

Set input B2 to Blocked Filter warning, enabled by Heat relay.

B2=FILTER/TIME
OFF SET/OK

Set input B2 to Blocked Filter warning, enabled by Time relay.

B2=AIRFLOW/HEAT
OFF SET/OK

Set input B2 to Air Flow Failure lockout, enabled by Heat relay.

B2=AIRFLOW/TIME
OFF SET/OK

Set input B2 to Air Flow Failure lockout, enabled by Time relay.

B2=MULTI OFF
OFF SET/OK

Set input B2 to multiple function.

PIN PROTECT
OFF SET/OK

Turn 'ON' to activate unique PIN code protection for Settings menu.

PIN ENTER:
**** SET/OK

4 digit unique PIN code setting.

RESET TO DEFAULT
NO SET/OK

Resets all of program and engineering data to default settings.

 After last pin digit is entered '0000' will be displayed to acknowledge code is entered. PIN protection will only take effect 30 seconds after the last button was pressed.

 Window changes to MENU END. Pressing OK returns to main display, Pressing SETTINGS button returns to first ENGINEERS SETTING.

5 Battery Cell information.

5.1 Battery replacement.

The real-time clock and program information is battery backed by a lithium coin cell. When mains power is interrupted the controller will retain the settings for up to seven days after which it will reset to factory default.

The battery has a service life of approximately five years. The condition of the battery is monitored and when replacement becomes necessary will be indicated on the display.



If, however the battery is removed and allowed to power down, all user programming will be removed and replaced by a manufacturers default setting.

If the LCD screen display appears 'blank' or 'freezes' during programming, power to the SmartCom³ will have to be removed to allow for the default settings to be recovered.*

In such a scenario, the lithium coin cell must be removed from the controller for a period of at least 10 seconds and then replaced.

To replace the battery, isolate the control from the mains electric supply and remove the plugs/screws securing the front panel to the rear case. Carefully remove the panel and detach the ribbon cable from the power PCB assembly.

Remove the old battery and fit the new battery as shown in the photograph. Please dispose of the battery responsibly.

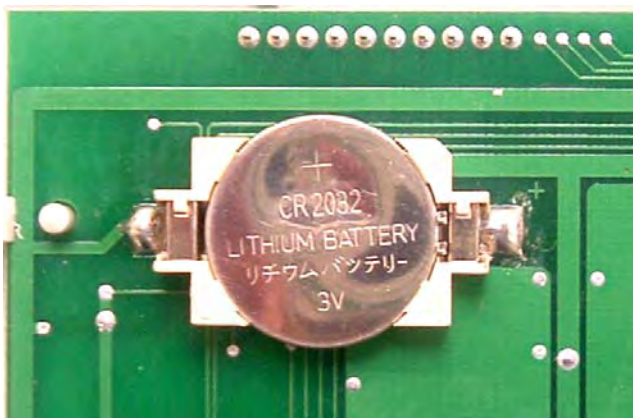

* Assuming ribbon cable connections have previously been checked for tightness, and connections are correctly made to both the pcb's .

5.1.1 Battery specifications

Reference: CR2032
Type: Lithium coin cell
Voltage: 3.0V
Service life: app. 5 years
Width: 20mm
Thickness: 3.2mm

Also known as: DL2032, BR2032, KL2032, EC-R2032, 5004LC, KCR2032, ECR2030, KECR2032, SB-T15, L14



AmbiRad Group

Heating and Ventilation Solutions

AMBIRAD **AIRBLOC** **NORDAIRNICHE** **BENSON**

A Thomas & Betts Company. Registered in England No. 1390934. Registered office: 27/28 East Castle Street, London.

AmbiRad UK is a registered trademark of AmbiRad Limited. Because of continuous product innovation, AmbiRad reserves the right to change product specification without due notice.

AMBIRAD LIMITED
Fens Pool Avenue
Brierley Hill
West Midlands DY5 1QA
United Kingdom

Tel: **01384 489 700**
Fax: **01384 489 707**

ambiradsales@tnb.com
www.ambiradgroup.co.uk

Document reference number **GB/SCOM/120/0114**
Replaces **GB/SCOM/120/0112**