

PRE-ENGINEERED VENTILATION AIR HANDLER

INDOOR system
BSHH range

OUTDOOR system
BRHH range



**Centrifugal Blown, Forced Convection Appliances with
Automatic Ignition and Fanned Flues for use as Multiple
Type B & C Appliances**

INSTALLATION – COMMISSIONING - SERVICING



These appliances meet the following EC Directives

DIR 2009/142/EC:GAD

DIR 2004/108/EC:EMC

DIR 2006/95/EC: LVD

DIR 2006/42/EC:MD

Please read this document carefully before commencing the installation and leave it with the user or attached to the appliance or gas service meter after installation!

WARNING

Improper installation, adjustment, alteration, service or maintenance can cause property damage, injury or death. All work must be carried out by appropriately qualified persons.

The manufacturer does not take any responsibility in the event of non-observance of the regulations concerning the connection of the apparatus causing an evil operation possibly resulting in damage to the apparatus and/or environment in which the unit is installed

Contents

1.	General	9.2	Ignition system
1.1	General	9.3	Operation
1.2	Warranty	9.4	Burner gas pressure adjustment
2.	Moving and Uncrating	10.	Two Stage Burners Setting and Adjustment
3.	Technical Data	11.	Gas Conversion
4.	Configurations and Dimensions	12.	Maintenance
5.	Location and Installation	12.1	Maintenance schedule
5.1	BSHH model	12.2	Heat exchanger maintenance
5.2	BRHH model	12.3	Burner maintenance
5.3	Duct connections	12.4	Burner orifice
6.	Combustion Air Supply and Flue System (only BSHH models)	12.5	Ignition system
6.1	General	12.6	Fan motor, fan
6.2	Type B appliances	12.7	Venter motor & wheel
6.3	Type C appliances	12.8	Operating gas valve
7.	Gas Connection	12.9	Combustion air pressure switch
8.	Electrical Connection	12.10	Limit controls
8.1	Electrical supply & connections	12.11	Fan delay relay
8.2	Thermostat controls	12.12	Flue and combustion air piping
8.3	Fan motors	12.13	Air filters
8.4	Wiring diagram	13.	Troubleshooting
9.	Commissioning, Lighting and Operation	14.	Spare Parts List
9.1	Commissioning	15.	User Instructions



If optional equipment was ordered and supplied with this heater, please refer to additional instructions for option(s).

1

GENERAL

1.1 General

Models BSHH/BRHH are design certified to the CE EN 1020 standard for use in industrial and commercial installations only. All models and sizes are available for use with either natural, propane or butane gas with operating temperature between -15°C and 40°C. The type of gas, input rate and the electrical supply requirements are shown on the heating rating plate.

Before installation, check if the appliance as described on the packaging label is in accordance with the correct type and model as specified on the data plate and complies with your customer order.

The installation manual is shipped with the heater. Verify that the literature is correct for the heater being installed. If the manual is incorrect for the heater, contact the supplier before beginning installation. The instructions in this manual apply only to the models listed.

Installation should be done by a suitable qualified installer in accordance with these instructions. The installer is responsible for the safe installation of the heater. BSHH/BRHH heaters have a titanium stabilised primary heat exchanger with a Macro Channel™ secondary heat exchanger.

After unpacking the appliance leave it fastened to the wooden blocks until just before siting to prevent damage to the base frame.

Please read this document before commencing installation.

These instructions are only valid for the country of use as indicated on the appliance i.e. GB - IE. If these symbols are not shown, it is necessary to obtain appropriate technical instructions, which will provide information concerning the necessary modification of the appliance for the conditions of use in the country concerned. Such instructions may be obtained upon request from your supplier.

Check if the local distributions conditions of electricity supply, type of gas and pressure of the appliance are compatible with the data plate. When installed in Great Britain the total installation must comply with the requirements and recommendations of British Standard BS 6230 1991 "Installation of Gas Fired Forced Convection Air Heaters for Commercial and Industrial Space Heating".

The installation must also be in accordance with the relevant requirements of "The Gas Safety (Installation and use Regulations) and "Amendment regulations 1990" and the "Building and "Electrical Regulations" (in GB the IEE Regulations).

The requirements of the "Local Building Standards office", the premises "Insurance" undertaking and the "Fire Office" must also be observed.

Unauthorised modification of this appliance or departure from use in the manner, for which it was intended by the manufacturer or installed in a manner contrary to these instructions, may constitute a hazard and jeopardize all warranties.

Deviations should only be carried out after formal consent has been obtained from the manufacturer.

Ensure the environment in which the air heater will be installed will not create a hazard i.e. where excessive (volatile) dust, flammable or corrosive substances and/or vapours and combustible materials may be present.

This appliance has been tested and set according to the data plate before leaving the factory.

IMPORTANT : BRHH model

Care must be taken when installing air heaters in outdoor locations to ensure that unauthorised access to the building cannot be gained via the appliance or its ductwork system. The BRHH unit can be installed using full fresh air or a combination of fresh air and recirculation air. In this case BRHH unit must be provided with an additional air intake completed with a water separator.

The BRHH unit is standard equipped with an anti-frost thermostat and electrical resistance to avoid freezing of the condensate in the condensate trap. The condensate drain downstream the trap needs to be protected by the installer.

Remark : condensate trap forms no part of standard delivery.

1.2 Warranty

Warranty is void if :

a. Heaters are used in atmospheres containing flammable vapours or atmospheres containing chlorinated or halogenated hydrocarbons or any contaminant (silicone, aluminium oxide, etc...) that adheres to the spark ignition flame sensing probe.

- b. Wiring is not in accordance with the diagram furnished with the heater.
- c. Unit is installed without proper clearance to combustible materials or without proper ventilation and air for combustion.
- d. Air throughput is not adjusted within the range specified on the rating plate.

2 MOVING and UNCRATING

This unit was test operated and inspected at the factory prior to packaging and was in proper operating condition. Before leaving the factory, the unit is completely assembled. If the heater has incurred damage in shipment, document the damage with the transport company and contact your supplier.

Read this booklet and become familiar with the installation requirements of your unit. If you do not have knowledge of local requirements, check with the gas supplier and any other local agencies that might have requirements concerning this installation.

Before beginning, make preparations for necessary supplies, tools and manpower.

Remark : the flue terminal for BRHH units is separately packed inside the unit. Install flue pipe terminal at the flue outlet before commissioning the unit.

Models 083 & 102 are equipped with a V-plate at left side of the terminal to avoid recirculation of flue gasses. Also install this plate before commissioning the unit.

IMPORTANT : BSHH model

If the installation includes optional vertical louvers or downturn nozzle etc., install these instructions before the heater is suspended. Follow the instructions included in the option package.

When transporting the appliance after it has been unpacked (i.e. fork lifting, etc) note the restrictions and recommendation indicated in figure 1.

The base frame contains internal support member, which acts as a lifting fulcrum point to prevent damage to the underside of the appliance by lifting forks.

Figure 1: Appliance Handling Criteria

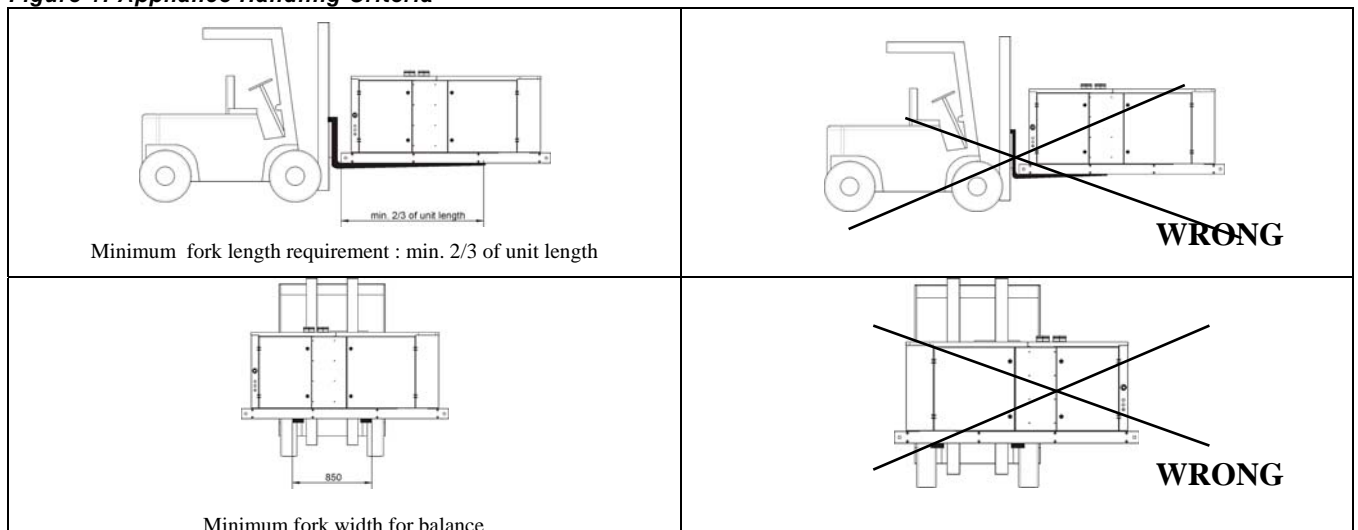

Tabel 1 :

BSHH (indoor) & BRHH (outdoor) unit type		055	083	102	
Gas categorie 'Cat.'		II2H3+			
Combustion air & flue type BSHH		B22p-B52-C12-C32-C42-C52-C62-C82			
Combustion air & flue type BRHH		Rooftop			
Heat input (Hs)	kW	58.60	87.68	107.66	
Heat input (Hi)	kW	52.80	79.00	97.00	
Heat output 100% (Hi)	kW	53.86	80.19	98.94	
Heat output 50% (Hi)	kW	26.93	40.10	49.47	
Thermal efficiency 100% (Hi)	%	102.6	101.4	102.2	
Burner pressure 100% (G20) ¹⁾	mbar	8.30	10.40	8.80	
Burner pressure 50% (G20) ¹⁾	mbar	2.08	2.60	2.20	
Burner pressure 100% (G31)	mbar	15.70	34.36	23.50	
Burner pressure 50% (G31)	mbar	3.92	8.59	5.87	
Burner pressure 100% (G30)	mbar	12.31	26.93	18.42	
Burner pressure 50% (G30)	mbar	3.07	6.73	4.60	
Burner injectors: Quantity 1	Nat. Gas (G20)	∅ mm	6.80	7.60	8.90
	Propane/Butane (G31/G30)	∅ mm	4.50	4.50	5.60
Gas supply pressure	Nat. Gas (G20)	mbar	20(GB) / 20(IE) ²⁾		
	Propane (G31)	mbar	37 ²⁾		
	Butane (G30)	mbar	28-30 ²⁾		
Gas consumption ³⁾	Nat. Gas (G20)	m ³ /h	5.59	8.36	10.26
	Propane (G31)	m ³ /h	2.16	3.23	3.97
	Butane (G30)	m ³ /h	1.64	2.45	3.01
	Propane (G31)	kg/h	4.12	6.16	7.57
	Butane (G30)	kg/h	4.17	6.23	7.65
NOX emission 100% G20		mg/kWh	127.32	128.48	129.79
NOX emission 50% G20		mg/kWh	78.48	97.81	112.22
Gas service connection		∅ ¾" BSP			
Flue & Combustion air connection collars (BSHH)		∅ mm	100	130	130
Minimum airflow ⁴⁾ at 15°C		m ³ /h	5500	8500	10000
Temperature rise at minimum airflow		K	28.6	27.6	28.9
Maximum airflow ⁴⁾ at 15°C		m ³ /h	8500	11800	14000
Temperature rise at maximum airflow		K	18.5	20.0	20.6
Electrical connections and Fan motor rating		0.75-5.5kW / 400V 3N~50Hz			
Total electric rating		kW	(Fan motor rating / 0,85) + 0,15		
Appliance weight net		kg	280	445	457
Protection grade		IP	20 (BSHH) / X4D (BRHH)		
Quantity primary heat exchanger elements			6	9	12

1) All burner pressures measured with all casing panels fitted and service door open. Pressure regulator sealed and not adjustable without high/low fire control.

2) G20: Pmin. 17mbar / Pmax. 25mbar---G30: Pmin. 20mbar / Pmax. 35mbar--G31: Pmin. 25mbar / P max. 45mbar.

3) Natural gas (G20): Hi 34,02 MJ/m³--Propane (G31): Hi 88,00 MJ/m³--Butane (G30): Hi 116,09 MJ/m³ @15 °C and 1013mbar.

4) Isothermic @15°C - maximum temperature rise 40K (Please check the separate leaflet 'ventilator curves for the desired airflow and/or static pressure with adjusted fan motor ratings).

Figure 2a : BSHH model

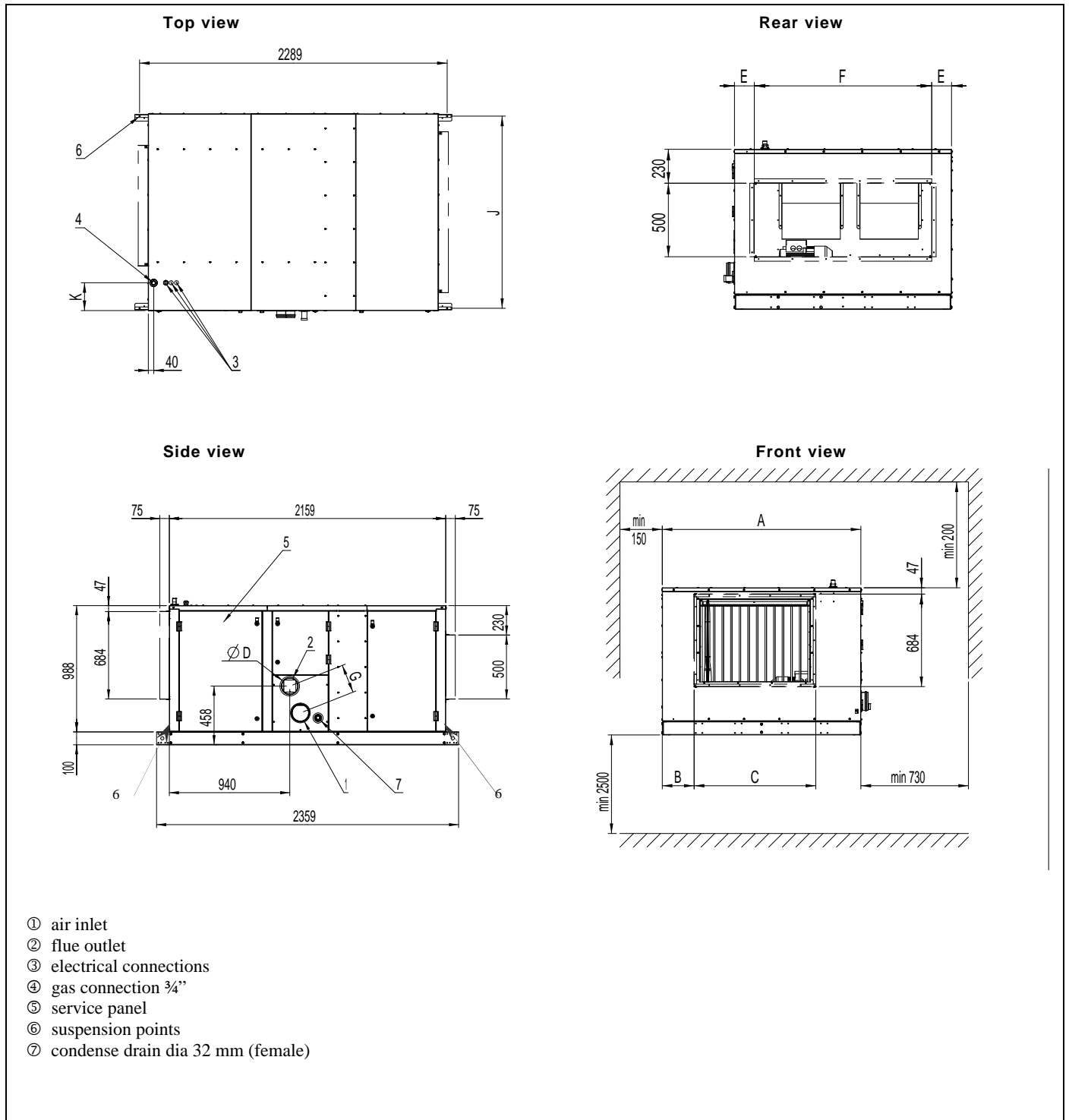

BSHH	A	B	C	$\varnothing D$	E	F	G	J	K
055	840	29	581	100	120	600	140	806	157
083	1468	236	899	130	134	1200	225	1434	301
102	1468	236	899	130	134	1200	225	1434	208

Figure 2b : BRHH model

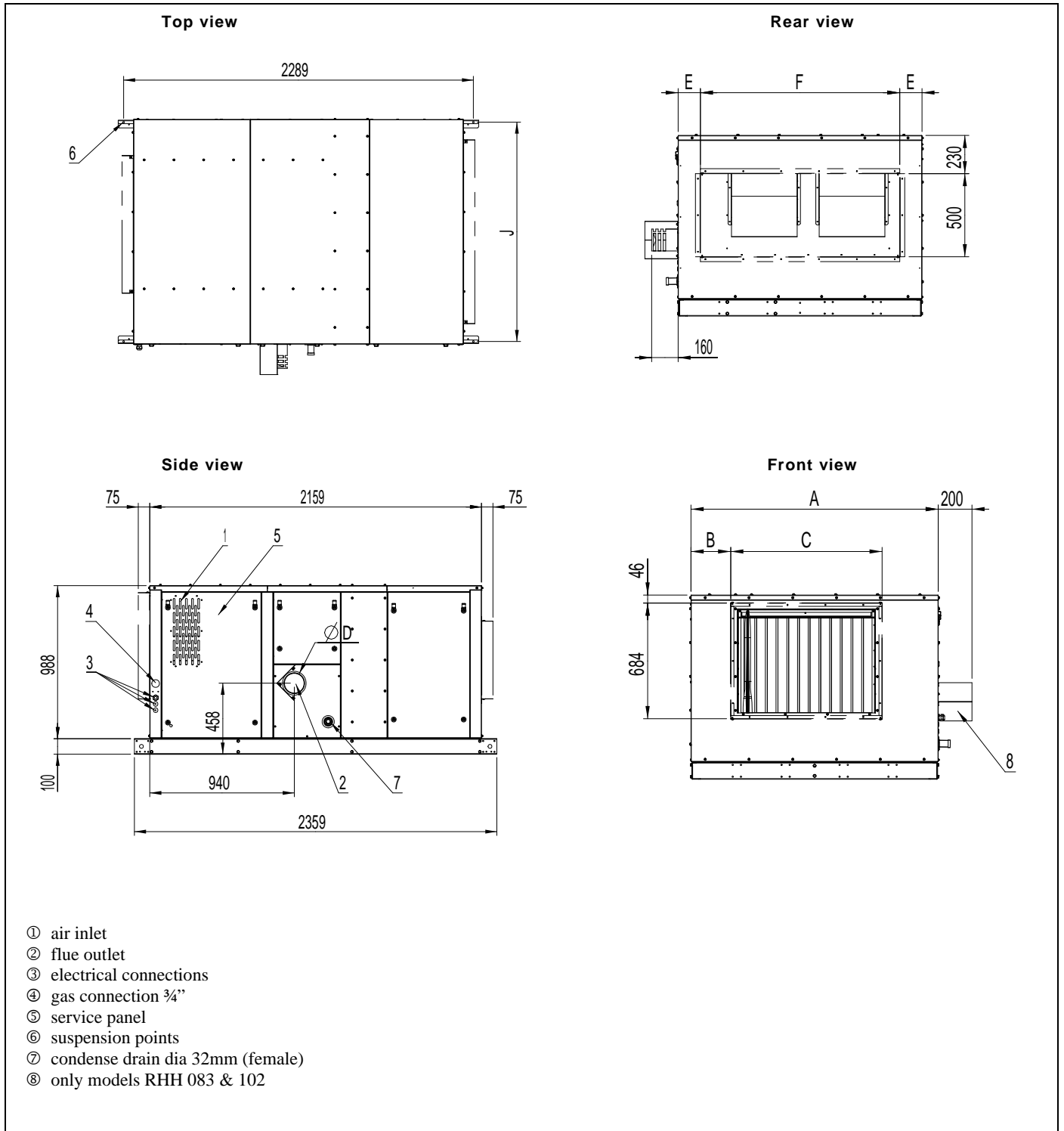

BRHH	A	B	C	∅D	E	F	J
055	840	29	581	100	120	600	806
083	1468	236	899	130	134	1200	1434
102	1468	236	899	130	134	1200	1434

5.1 BSHH Model

5.1.1 Location heater

For best results, the heater should be placed with certain rules in mind. Always ensure that minimum clearances are maintained (cfr. figure 2a). When possible, heaters should be arranged to blow toward or along exposed wall surfaces.

Suspended heaters are most effective when located as close to the working zone as possible, but care should be exercised to avoid directing the discharged air directly on to room occupants.

Partitions, columns, counters or other obstructions should be taken into consideration when locating the unit heater so that a minimum quantity of airflow will be deflected by such obstacles.

When units are located in the centre of the space to be heated, the air should be discharged toward the exposed walls. In large areas, units should be located to discharge air along exposed walls with extra units provided to discharge air in toward the centre of the area. For optimum results heaters are best used in conjunction with recirculating air fans suspended at high level.

At those points where infiltration of cold air is excessive, such as at entrance doors and shipping doors, it is desirable to locate the unit so that it will discharge directly toward the source of cold air, typically from a distance of 4.5 to 6.0 meters or install a down flow unit over the door opening.



Do not locate the heater where it may be exposed to water or where the ambient temperature exceeds 40°C.

The presence of chlorine vapours in the combustion air of gas-fired heating equipment presents a potential corrosion hazard.

Care should be taken to separate these vapours from the combustion process. This may be done by wise location of the unit flue and combustion air terminals with regard to exhausters or prevailing wind directions. Chlorine is heavier than air. Keep this fact in mind when determining installation location of the heater in relation to building exhaust systems.

Where chlorine vapours are prevalent heaters with special grade 316 AISI stainless steel heat exchangers are recommended.

5.1.2 Installation heater

Figures 2a/2b shows the clearances necessary to ensure that safety from combustibles and for servicing are maintained. In the event that the appliance is required to be installed on the floor then a non-combustible base must be provided.

Installation on a base is required when the air handler is composed of more than a heating and ventilation section – suspension becomes here forbidden.

In case the installation is done by means of supporting points, make sure that the distance between supporting points does not exceed 1.5m. In general it is recommended to support the base where it is screwed down with supporting points.

Ensure that the structural elements, which will be used to suspend or support the appliance, are adequate to carry the weight of the appliance and its ancillary components i.e. the flue system.

The location where the air heater is to be installed must provide sufficient space around the heater for servicing and clearances for safety. Beware to allow space for the passage of vehicles i.e. lift trucks, etc ...

Ensure that the air heater is installed in a level plain.

The heater must be fastened securely to any base mount framework.

Four-point suspension is possible from the Ø 11.0 mm holes provided in the base frame. Using drop rods etc. Ensure that suspension fixings are lock nut secured to secure against loosening.

When suspended, the air heater should be rigid so as to avoid placing a strain on the flue system and connected services.

Figure 3 : Detail fixation (only if unit & framework is a one-part construction)

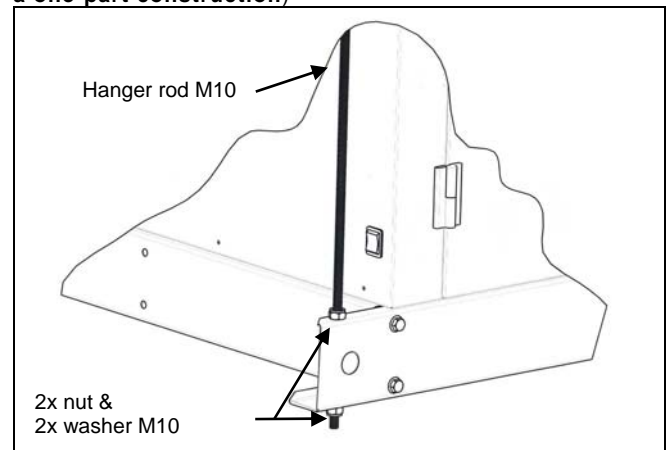

Table 2: Clearances (mm) (we also refer to figure 2a)

BSHH BRHH	Minimum distance wall not controls side	Minimum distance wall controls side	Minimum distance floor- bottom	Minimum. distance ceiling-top
055	150	730	2500	200
083	150	730	2500	200
102	150	730	2500	200

5.2 BRHH Model

5.2.1 Location heater

When installing ensure the total outdoor elements of the installation will not jeopardize the integrity of the premises security.

A distance of 500 mm must be maintained between the deck on which the appliance is installed and any air inlet to the appliance. We also refer to figure 2b.

The location where the air heater is to be installed, must provide sufficient space around the heater for servicing and to allow the flue products to escape freely. A minimum distance of 1500 mm must be maintained on the controls side of the appliance.

When installed at ground level the entire installation should be protected by a fence to guard against damage and to protect the public from possible injury.

5.2.2 Installation heater

Ensure that the structural elements which will be used to support the appliance are adequate to carry the weight

of the appliance and its ancillary components i.e. the ductwork system.

Ensure that the air heater is installed in a level plain and that the surface onto which it is installed is vibration free. The air heater must be fastened securely to any base mount frame work. Roofcurbs are manufactured from galvanised mild steel and should be fixed prior to siting the appliance.

It is necessary to provide weatherproof seals between the appliance and the structural elements of the building. Exposed ducting should be insulated and covered with a weatherproof membrane.

The duct connection to the appliance should be made using flexible connections to reduce noise transmission and allow for thermal expansion of the air heating module.

When siting the appliance and unloading, extreme care must be exercised to ensure that the slings etc employed do not damage the casing. The weatherproofing will become unsealed should any damage be sustained. Sling spreaders must be used to provide clearance between the appliance and the slings. Figure 4 shows the location of spreaders and slinging points provided for this purpose.

Figure 4 : Lifting sling points (Use all provided sling points !)

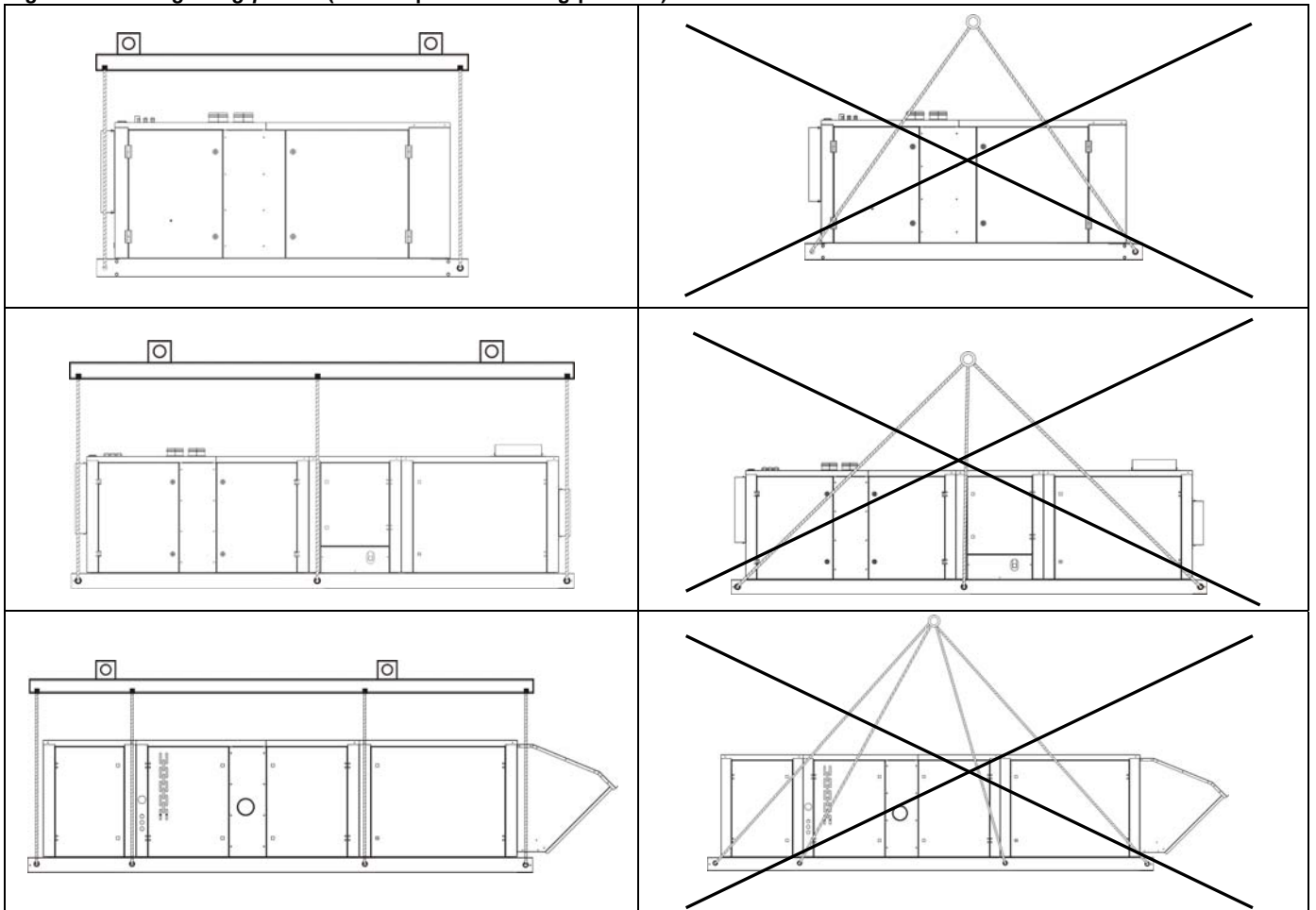

5.3 Duct connections

The air heaters are designed to be used in conjunction with intake and or discharge ducting. A positive seal should be made between any ducting and the air heater. A flexible connection is desirable to eliminate transmission of noise and to take account of thermal expansion. Figure 5 illustrates a method of connection between the appliance and the duct using a proprietary patented connection system.

Consideration should be given to the application of duct fittings directly connected to the appliance. Air inlet and outlet elbows, transitions etc. should be designed to ensure an unrestricted and turbulent free air flow. This requirement is to ensure that an even air temperature is maintained when leaving the appliance thus eliminating heat exchanger "hot-spots" and nuisance shut-down of the burner due to over heating.

Figure 5 : Recommended procedure and method for connection of ducting and transitions to the air heaters using a typical proprietary flange system.

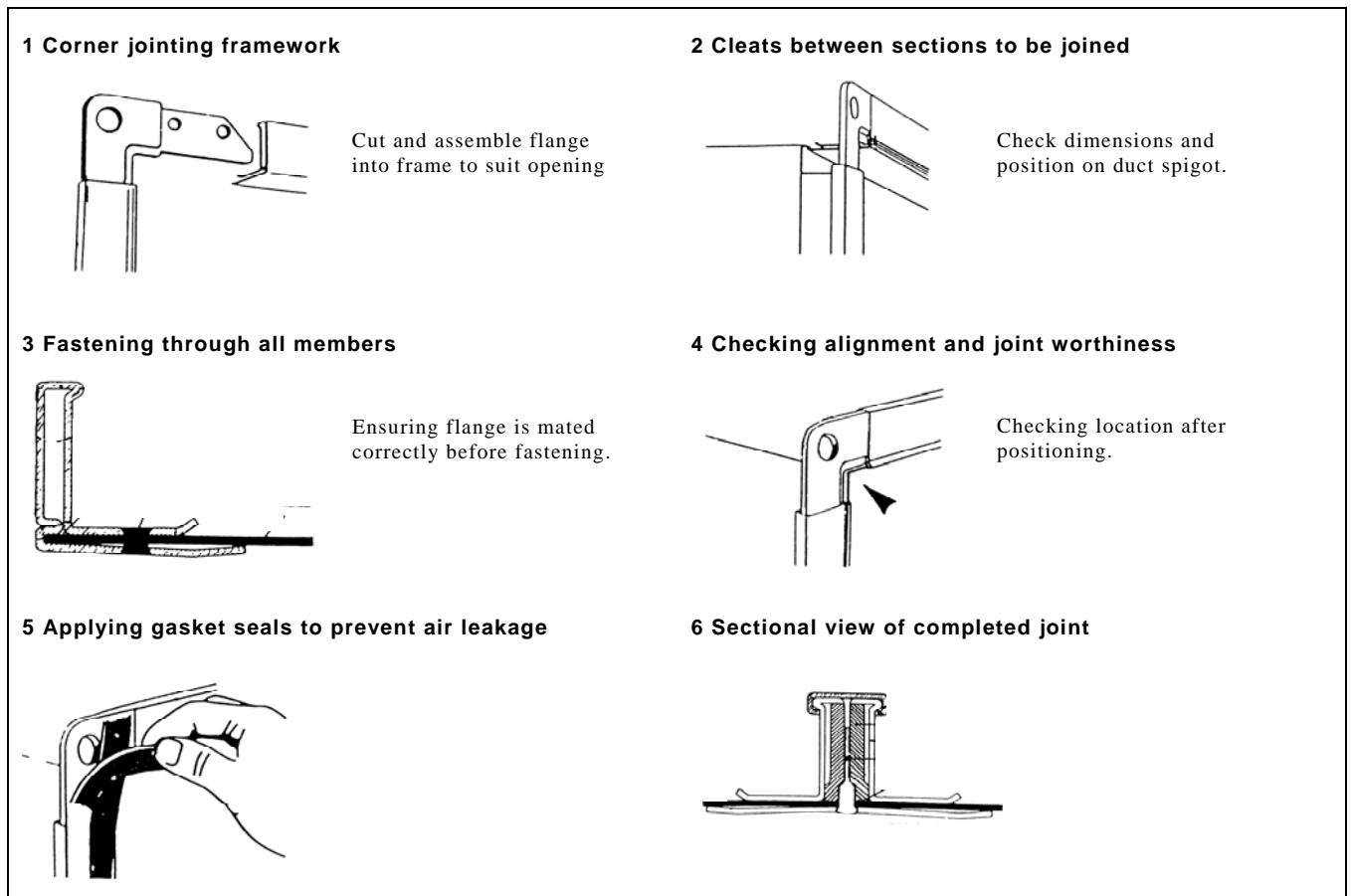

6 COMBUSTION AIR SUPPLY & FLUE SYSTEM

THIS SECTION ONLY APPLIES TO BSHH models

6.1 General

6.1.1 Flue requirements

IMPORTANT
The flue must be installed in accordance with national and local regulations. Failure to provide proper flueing could result in death, serious injury and/or property damage. The air heater must be installed with a flue to the outside of the building. Safe operation of any power vented gas apparatus requires a properly operating flue system, correct provision for combustion air and regular maintenance and inspection.

Model BSHH heaters may be installed as Type-B and Type-C installations.
Flue must be in accordance with BS6230 or BS5440. Local requirements may apply in addition to national requirements. These unit heaters are designed to operate safely and efficiently with either a horizontal or vertical flue system when installed with the specific requirements and instructions.
If this heater is replacing an existing heater, be sure that the flue is sized properly for the heater being installed and that the existing flue is in good condition.

A properly sized flue system is required for safe operation of the heater. An improperly sized flue system can cause unsafe conditions and/or create condensation.

The air heaters may be installed as a balanced flue (type C) heater requiring both a combustion air inlet duct and a flue pipe or as a power vented heater (type B) (the combustion air is taken from the space where heater is installed), which requires only a flue pipe exhausting to outdoors.

All products of combustion must be flued to outdoor atmosphere. Each heater installed as a type B appliance must be fitted with an individual flue pipe and the combustion air inlet opening must be provided with a protection grill.

Each heater installed as a type C appliance must be fitted with an individual combustion air/flue pipe system.

Type C2 appliance, with single duct system for supply of combustion air and evacuation of flue gasses, are not allowed.

6.1.2 Diameter & maximum flue pipe lengths

Flue pipe diameters and maximum pipe lengths in table 3 apply to both horizontal and vertical systems.

Add all straight sections and equivalent lengths for elbow. The total combined length must not exceed the maximum flue length.

6.1.3 Venter outlet attachment requirements

Depending on the size of flue pipe as determined in table 3, attach either the flue pipe directly to the collar or a taper-type connector.

Table 3 : Maximum flue system pipe lengths

BSHH			055	083	102
Heater socket & pipe dia	mm	flue pipe	100	130	130
		inlet pipe	100	130	130
Max straight length hor. flue outlet connection	m	flue pipe	9	9	9
		inlet pipe	9	9	9
Max straight length vert. flue outlet connection	m	flue pipe	9	9	9
		inlet pipe	9	9	9
Equivalent length of 45° elbow	m	flue pipe	0,75	0,75	0,75
		inlet pipe	0,75	0,75	0,75
Equivalent length of 90° elbow	m	flue pipe	1,5	1,5	1,5
		inlet pipe	1,5	1,5	1,5

- Use only one type of flue pipe dia
- recommended minimum flue length = 1m

IMPORTANT : CONDENSE DRAIN

A condensate drain with trap must be fitted to the unit to properly drain all condensation. The flue must be installed in accordance with national and local regulations. Failure to provide proper flueing could result in death, serious injury and/or property damage. The air heater must be installed with a flue to the outside of the building. Safe operation of any power vented gas apparatus requires a properly operating flue system, correct provision for combustion air and regular maintenance and inspection. The combustion products are loaded with moisture, some of which will condense out within the flue. No condensate leakage is permitted. BSHH indoor horizontal flue runs must rise by 1° (17mm per meter) from the appliance to ensure that the condensate returns to the flue drain.

Gasket sealed single wall seamless heavy gauge aluminium pipes are required for use with condensing gas appliances. All joints must be sealed to prevent leakage of flue gases or condensation into the building. For testing, the flue pipe should include a sealable test point. Ideally the test point should be at least 450mm away from the air heater flue connection socket. However if a concentric flue is attached directly to the connection sockets then the combustion should be tested through the flue outlet collar via a drilled test point which must be securely plugged on completion. Follow the flue pipe manufacturers installation instructions for making joints, including connections to the air heater, for passing through a building element and for support requirements.

REMARK :

BRHH outdoor units will be standard supplied with an anti-frost thermostat and electrical heating resistance to protect the condensate against freezing (see pictures 6a thru 6e) (not BSHH units)

Figure 6a

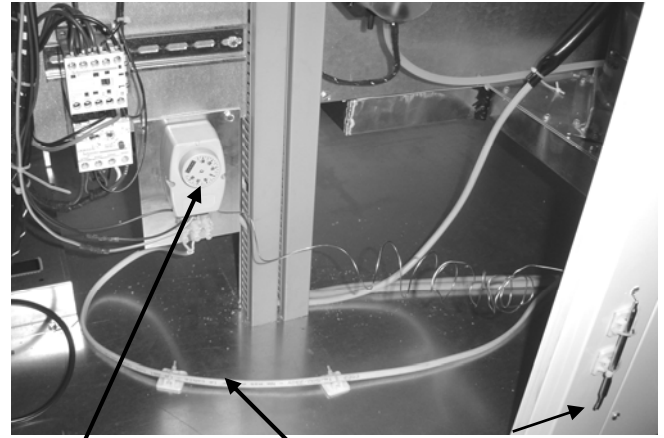

Antifrost thermostat inside unit to be set at 3 - 5°C
Electrical heating resistance
External sensor for antifrost thermostat

Figure 6b

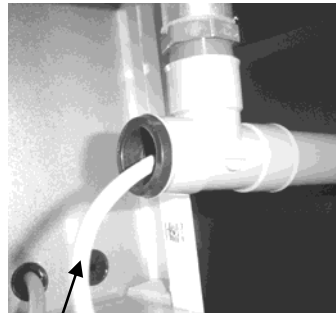

Electrical heating resistance

Figure 6c

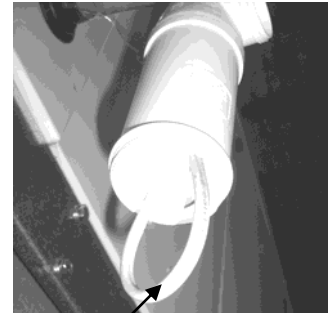

Electrical heating resistance positioned inside condensate trap

Figure 6d

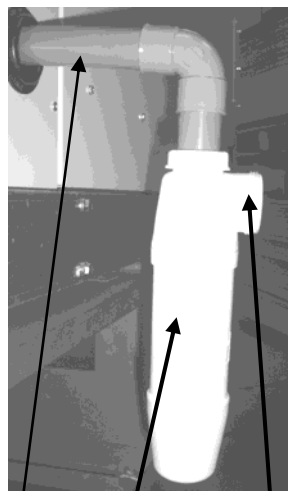

Condensate trap (option nr OP928)

Connection for PVC tube dia 40mm

Dia 32mm connection

Figure 6e

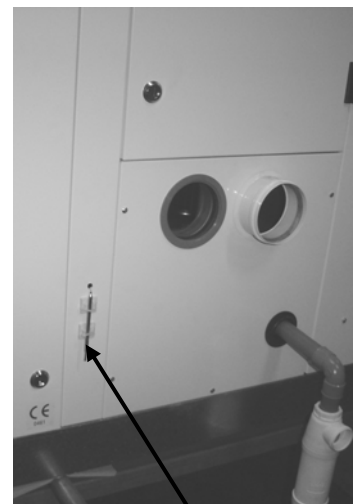

Sensor thermostat

For **BSHH & BRHH** units, a PVC tube with collar of dia 32 is provided to drain the condensate from the heat exchanger. The condensate trap is optional.

Ensure that dimensioning of condensate drain can handle condensate rates as indicated below.

Condensate drain rates of flow

BSHH/BRHH		055	083	102
Nat. gas	l/h	22	33	41
Propane	l/h	13	19	24

REMARK : Fill condensate trap with clean water before commissioning the unit.

Figure 6f

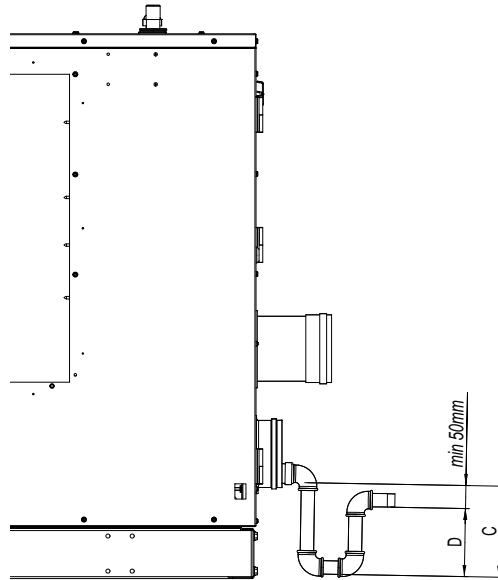

D = minimum 130mm
 C = D + minimum 50mm (= min. 180mm)



Condensate trap (option nr OP928)

6.2 Type B appliances

6.2.1 Flues for power vented installations

If the air heater is to be installed as a type B appliance, air for combustion will be taken from within the space where the heater is installed.

Single wall flue seamless aluminium or stainless steel pipes are required. All joints must be sealed to prevent products of combustion from leaking into the building. If the flue passes through a combustible element of the building it must be enclosed by a sleeve of non-combustible material and separated from the sleeve by a minimum of 25 mm air break. The temperature of any combustible material near to the flue must not exceed 65°C when the heater is in operation. The flue must be at least 150 mm away from any combustible material.

Single wall flue pipe exposed to cold air or run through unheated areas should be insulated. Where condensation is unavoidable, provision must be made for the condensation to flow freely to a point to which it can be released, i.e. a drain or gully. The condensation drain from the flue must be constructed from non-corrodible material not less than 20 mm diameter. Copper or copper based alloys must not be used for condensation drains.

For testing, the flue pipe should include a sealable test port. The port must be at least 450 mm away from the air heater flue connection socket.

Follow the flue pipe manufacturers installation instructions for making joints, including connections to the air heater, for passing through a building element and for support requirements.

6.2.2 Air supply

Ensure that an adequate air supply for combustion and ventilation is provided within the building in accordance with BS6230/BS5440 plus other relevant regulations & rules in force.

It is important to ensure that there is an adequate air supply at all times for both combustion and heating requirements.

Modern buildings involve greater use of insulation, improved vapour barriers, and weather proofing. These practices mean that buildings are sealed much tighter than in the past.

Proper combustion air supply for a power vented Type B installation requires ventilation of the heated space. Natural infiltration of air may not be adequate. Use of exhaust fans aggravates this situation. It is important to ensure that there is adequate combustion air supply at all times. Reliance on doors and windows is not allowed.

Ensure that the air combustion inlet opening at the side of the unit cannot be obstructed (cfr. fig 7b).



When these air heaters are installed in type B applications, designed to take air for combustion from the space in which it is installed. Do not restrict the combustion air intake.

Figure 7a : Approved appliances type B

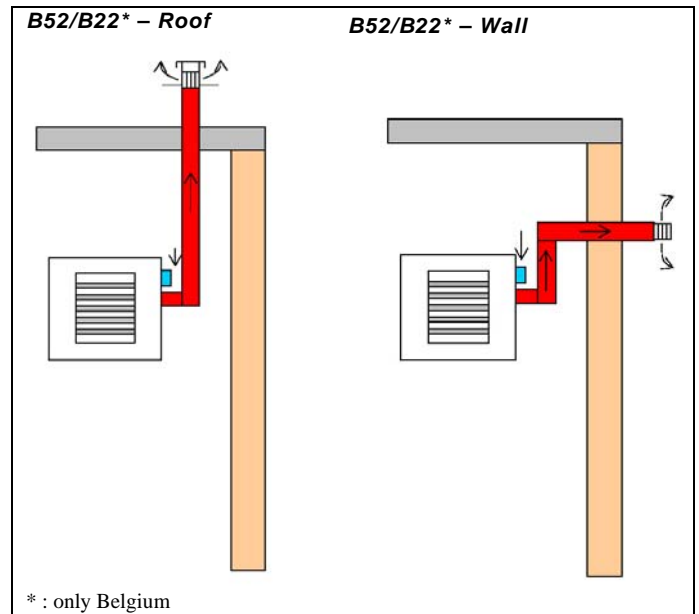
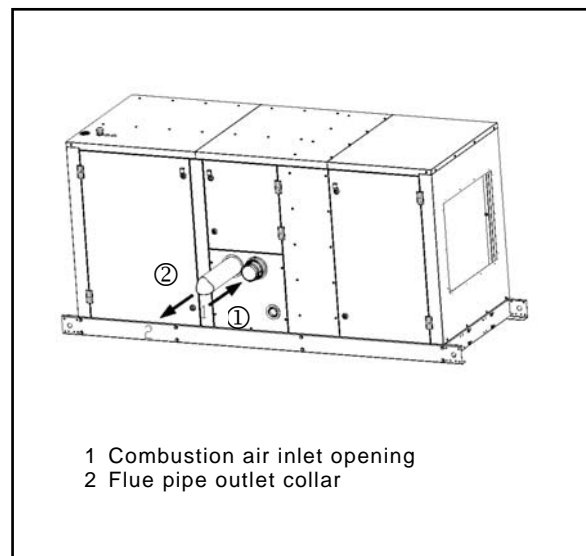

Figure 7b : Type B appliances – Combustion air and flue pipe sockets



6.3 Type C appliances

Balanced flue air heaters are designed to be fitted with a combustion air inlet duct that obtains outdoor air and a flue pipe that exhausts flue products to outdoors. Single wall flue seamless aluminium or stainless steel pipes are required. All joints must be sealed to prevent products of combustion from leaking into the building. If the flue passes through a combustible element of the building it must be enclosed by a sleeve of non-combustible material and separated from the sleeve by a minimum of 25 mm air break. The temperature of any combustible material near to the flue must not exceed 65°C when the heater is in operation. The flue must be at least 150 mm away from any combustible material.

Single wall flue pipe exposed to cold air or run through unheated areas should be insulated. Where condensation is unavoidable, provision must be made for the condensation to flow freely to a point to which it can be released, i.e. a drain or gully. The condensation drain from the flue must be constructed from non-corrodible material not less than 20 mm diameter. Copper or copper based alloys must not be used for condensation drains. For testing, the flue pipe should include a sealable test port. The port must be at least 450 mm away from the air heater flue connection socket.

Follow the flue pipe manufacturers installation instructions for making joints, including connections to the air heater, for passing through a building element and for support requirements.

Type C2 appliances must not be applied !

Figure 8a : Type C appliances - Combustion air and flue pipe sockets

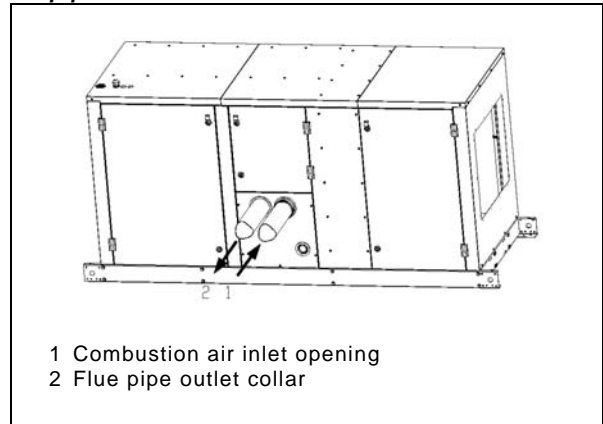
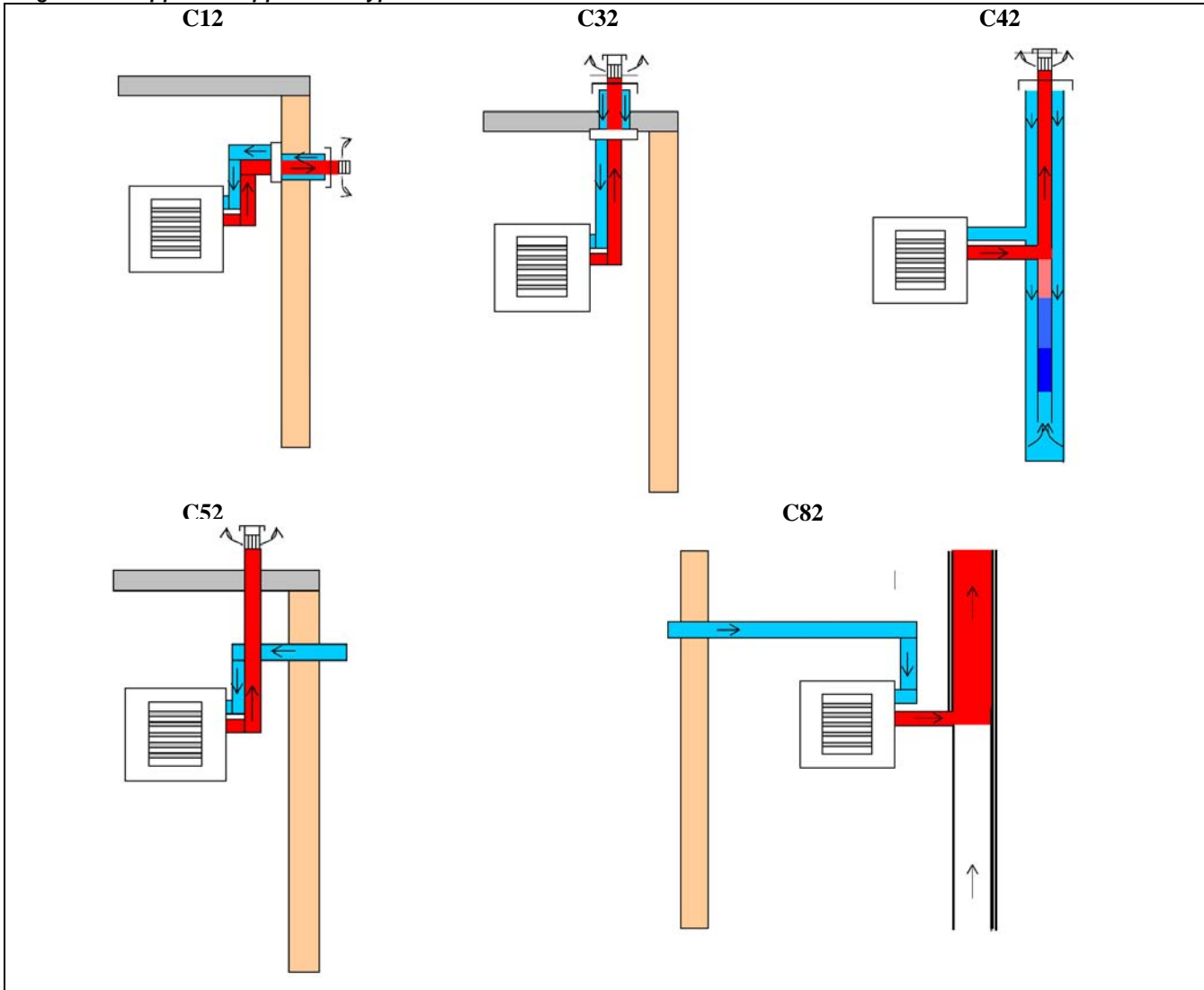



Figure 8b : Approved appliances type C



Concentric wall or roof terminal needs to be Mugro type 2000 (M&G) or Burfix (dia 100 or dia 130)

Connection to a gas service may only be carried out by suitably qualified persons.

All piping must be in accordance with requirements outlined in the National Gas Codes (different for each country). Gas supply piping installation should also conform to good practice and any local codes. Support gas piping with pipe hangers, metal strapping, or other suitable material.

 **Do not rely on the unit to support the gas pipe!**

All sealing products shall be resistant to the action of liquefied petroleum gas or any other chemical constituents of the gas being supplied.

Install a ground joint union and manual shutoff the gas cock upstream of the unit control system (see figure 9).

The unit is equipped with a nipple that extends outside the cabinet. The gas connection is 3/4".

Leak test all connections by brushing on a leak detecting solution.

Check that the gas category is in accordance with the data described on the air heater.

An adequate gas supply sized to provide the dynamic pressure for the volume required by the air heater(s) is essential to maintain the nominal heat input.

Ensure that a gas supply line includes a filter and has been tested and purged in accordance with prescribed practice prior to commissioning and taking the air heater into service.

This appliance is equipped for a maximum gas supply pressure of 50mbar.

Pressure testing supply piping: test pressures above 50mbar: disconnect the heater and manual valve from the gas supply line that is to be tested. Cap or plug the supply line..



NEVER use a FLAME to test for GAS SOUNDNESS !

Figure 9a : Gas connection detail of BSHH unit

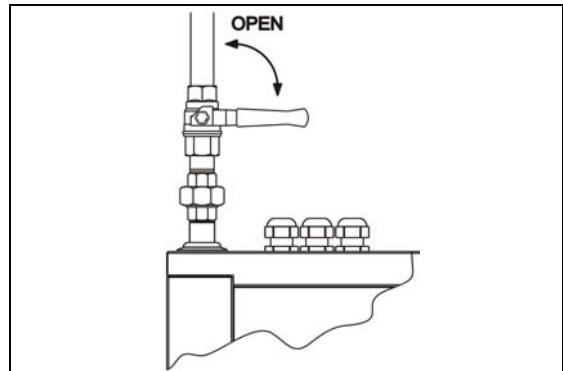
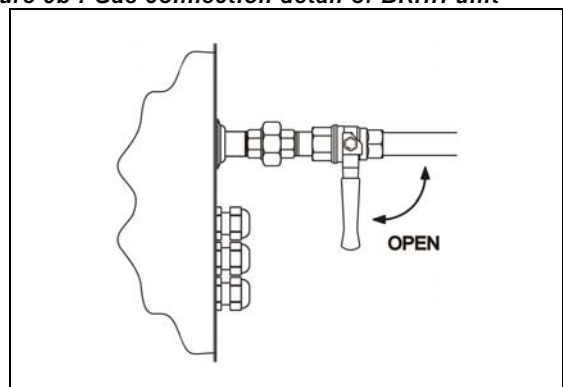

Figure 9b : Gas connection detail of BRHH unit



8.1 Electrical supply & connections

Attention: Serious damage can occur to burner relay when faulty connection of thermostat, reset switch or burner failure lamp. Switching of wires for reset switch and flame failure (e.g. in a remote control box) will destroy the burner relay.

The electrical installation may only be carried out by an appropriately qualified person current to IEE Regulations. The supply line to the heater should include a main switch adjacent to the appliance. The minimum clearance distance between the contacts must be more than 3 mm.

All electrical connections should be made in the heater control compartment (refer to figure 10). Connections should be in accordance with the terminal markings and the wiring diagram affixed to the air heater.

The minimum external control required for the air heater is a room thermostat. **It is essential that the main input line and neutral to terminals L and N remain live at all times even when the heater is switched off to ensure correct operation of the unit and to let the fan operate independent of the heating control. Never incorporate controls that isolate the appliance electrically.**

A burner reset switch with red indicator light is fitted on the heater. To add a remote reset button, make connections to the terminals in the electric box as indicated on the wiring diagram.

IMPORTANT

If the reset button requires activating for any reason, the cause must be determined. After determining and correcting the problem, restart the heater and monitor long enough to ensure proper operation (approx. 5 minutes).

Check that the electrical specification is in accordance with the specified data on the air heater. A unique appliance wiring diagram is supplied as a separate document attached to this one plus an additional copy attached to the air heater.

These appliances **must** be earthed.

8.2 Thermostat controls

Ancillary controls are required to provide timed heat cycles, room comfort temperature level, frost protection, override air circulation etc. These are not included with the appliance and should be ordered separately. **Do not attempt to control more than 1 air heater from a single thermostat or control panel unless a**

properly wired relay is fitted. Follow the instructions supplied with such panels.

The location of the room thermostat or sensor is very important. It should not be positioned on a cold wall or cold surface. Avoid location in draughty areas or where it may be influenced by heat sources e.g. the sun, process plant, etc. The thermostat should be mounted on a vibration free surface and mounted about 1,5 metres above floor level. Follow the thermostat manufacturers instructions. The thermostat must be suitable for potential free contacts.

8.3 Fan motors

The centrifugal blowers fitted to the BSHH/BRHH air heaters are of the forward curved type therefore, the speed setting for the static pressure imposed by the air distribution system will govern the motor loading.

All BSHH/BRHH air heaters leave the factory with the drives set to the specified conditions of the appliance. Table 4 provides the motor characteristics for the various sizes.

Refer to section 9 to learn how to carry out adjustments necessary to alter the fan speed and motor load factors.

Table 4 : Maximum motor load rating

Motor rating	kW	0,75(1)			1,1		1,5		2,2		3		4		5,5	
Phase	~	1	3	3	3	3	3	3	3	3	3	3	3	3	3	3
Voltage	V	230	230	400	230	400	230	400	230	400	230	400	230	400	230	400
Load rating	A	5,2	3,3	1,9	4,5	2,6	5,9	3,4	8,3	4,8	11,2	6,5	14,9	8,6	19,2	11,1

(1) only possible on 083 model

8.4 Wiring connections on the terminal board

Figure 10 :

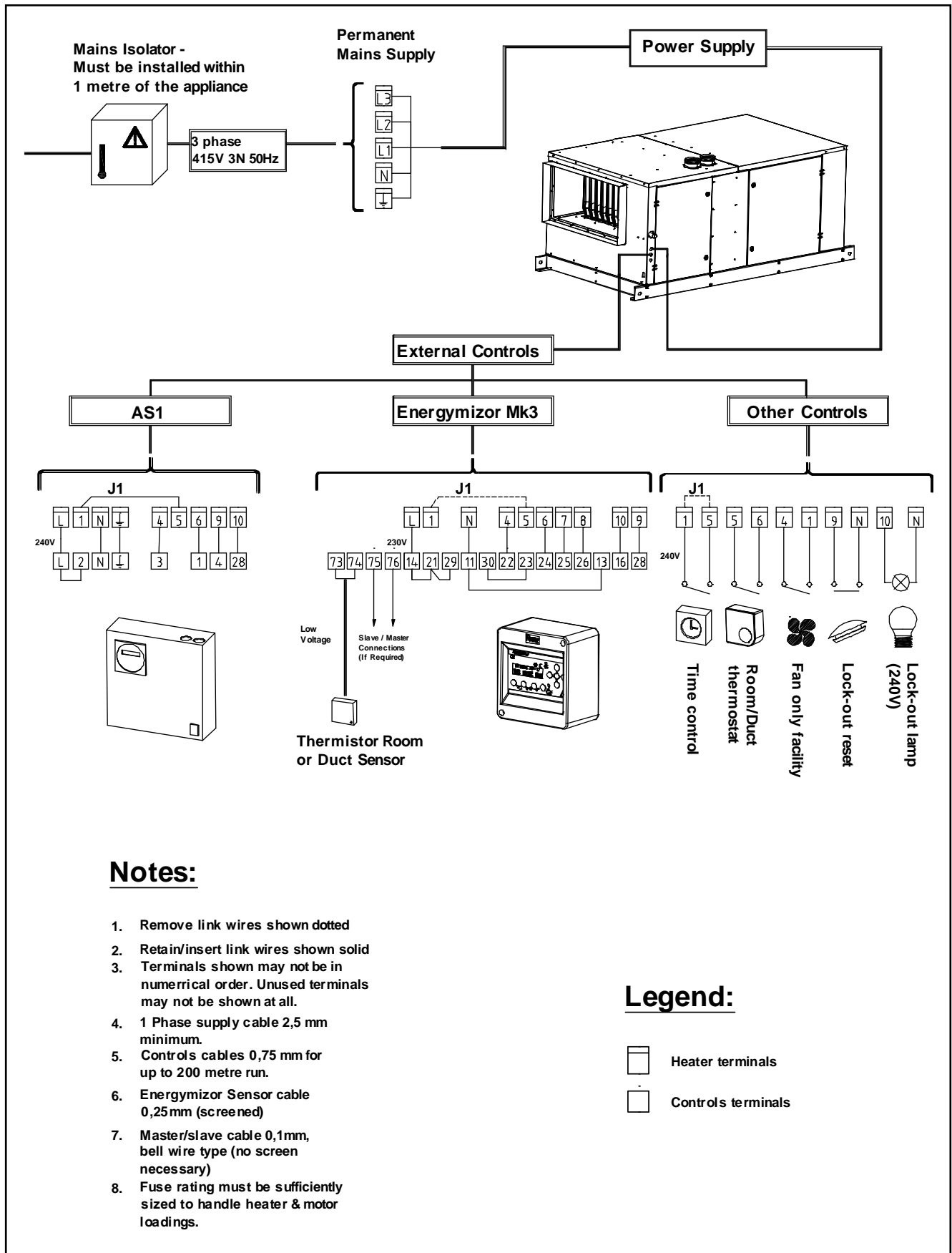

9.1 Commissioning

Normally BSHH/BRHH air heaters do not require commissioning. Final testing after production ensures that, if installation has been carried out by a suitably qualified person and strictly in accordance with this document, the appliance is ready to be taken into service.

Note : Outdoor commissioning work on BRHH appliances should not be undertaken during wet conditions, a second person must be available to provide assistance in the event of an emergency.

9.1.1 Checks

Prior to start up heater, carry out following checks to ensure :

- o Check suspension (BSHH) or unit support (BRHH). Unit must be secure. Verify that no other parts are fitted which are not individually supported and secured.
- o Check piping for leaks and proper gas line pressure. Bleed gas lines of trapped air.
- o Check electrical wiring and ensure that wiring conforms to the wiring diagram. Be sure all wire sizes meet requirements.
- o Phase supply cable to correct terminals.
- o Check polarity. Verify that line voltage exists between the black "L1" and earth ground.
- o Verify that the appliance is earthed by conducting an earth continuity test.
- o Current rating and fuse value.
- o Correct supply gas pressure.
- o Correct burner gas pressure.
- o Satisfactory & smooth ignition.

Supplementary checks in case of an BSHH installation:

- o Check clearances from combustibles. Requirements are in section 5.
- o Check vent system to be sure that it is installed according to the instructions in section 6, venting requirements.
- o Check if condensate drain trap is filled with clean water.

9.1.2 Heater start-up



For your safety, follow the instructions exactly otherwise damage or injury could occur !

- o This heater does not have a pilot flame. It is equipped with an ignition device that automatically lights the burner. Do not try to light the burner by hand.
- o Before operating, smell all around the heater area for gas. Be sure to smell next to the floor because propane gas is heavier than air and will settle near the floor.
- o Do not use this appliance if any part has subjected to water ingress. Immediately call a qualified service technician to inspect the appliance and to

replace any part of the control system and any gas control.

- o When overheating occurs or when gas supply is not turned off, shut the manual gas tap before turning off the electric power.
- o In addition to the above requirements checks to ensure that the fan performance and motor load factors are correct for the application and in accordance with the appliance data plate.

9.1.3 Drives : general and adjustments

Adjustment may be necessary to set the fan duty for the static pressure and motor load requirements. Before starting work on the fan assembly:

- o Set external controls to off or their lowest setting.
- o Turn **OFF** the gas supply to the air heater.
- o Switch **OFF** the electricity supply to the air heater after the air circulating fan has stopped.
- o Carry out adjustments as appropriate.

N.B. Rotational speed checks should be carried out using an infrared tachometer or stroboscope.

Adjusting the fan speed can be carried out by altering the diameter of the adjustable drive pulley on the motor shaft.

- o Loosen the belt tension device and remove the drive belt.
- o Refer to figure 11 and note that the outer section of the drive pulley is secured by a hexagon socket screw to a flat on the pulley hub, this is positioned by loosening the hexagon socket screw sufficiently to enable the pulley to be either opened or closed by turning it on the thread on which it is engaged.
- o It should be noted that one complete turn of the pulley half is equal to approximately 8% of the fan speed. Closing the pulley increases the speed and opening decreases the speed.
- o After making speed adjustments tension belt in accordance with the dimensions given in figure 11 and check pulley alignment to ensure the belt runs correctly.

N.B. Always ensure that the pulley is tightened onto a flat of the hub before switching on the fan, even when testing a reset condition.



Opening the pulley too far will cause the belt to touch the bottom of the V groove resulting in a significant reduction of belt life time and loss of grip.

If the amount of adjustment is not achieved with the range obtainable with the pulleys fitted, it will be necessary to change the driven pulley fitted on the blower and possibly the size of the drive V belt. After adjustment ensure the motor load rating is not exceeded!

Figure 11 : Pulley and drive belt adjustment

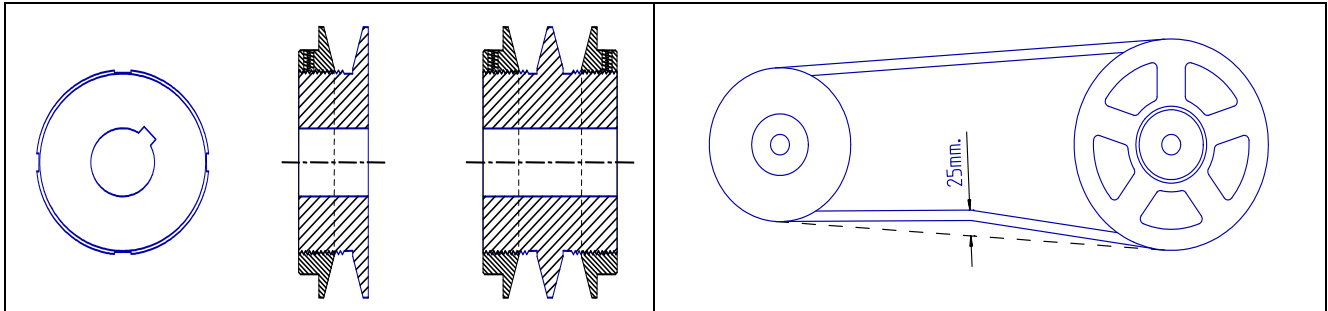

9.2 Ignition system

- o Ensure that air discharge louvers are set to open.
- o Switch on electrical supply.
- o Turn on gas supply.
- o Set time switch (if fitted) to an 'ON' cycle.
- o Set room thermostat to 'ON' position.
- o If reset button on heater and/or on remote control (if fitted) lights up, press reset button.
- o Thermostat calls for heat, energizing the venter motor.
- o When adequate airflow for combustion is proven by an air proving switch and a prepurge period has elapsed, the integral igniter and multifunctional gas control operate. The ignition spark ignites the gas creating the burner flame.
- o Burner flame is sensed by a flame rod sensor and when the heat exchanger is warmed up (+/- 30 seconds) and the fan control relay closes, the fan motor is energized.
- o .If the flame is extinguished during the main burner operation, the integrated control system closes the main valve and attempts to relight the burner. The unit will attempt 5 ignitions before entering a "lock out" mode. Lock out is indicated by the red warning light on the heater. To end this mode push on the reset switch.
- o For a new installation or if the appliance has been turned off for an extended period then up to 3 attempts to light the air heater may be necessary. If the heater still does not light, consult the fault-finding guide.

If the burner flame is extinguished for any reason during a run cycle, an automatic attempt for re-ignition will take place, if the burner does not relight after 5 attempts, then safety shut down and lockout will occur. Manual intervention to reset is necessary to put the air heater back into service.

In the event of overheating for any reason, thermally activated fail safe overheating controls operate to switch off the burner.

The overheat control (LC3), will switch off the burner and itself set to a lockout condition which also requires manual intervention to reset to restore the heater to operational condition. A cooling time of ± 1 minute is necessary before thermal re-setting can be carried out

When the set temperature or the heating time period has been reached, electrical power to the burner relay will be switched off and the burner will extinguish. In case of a not continuous running fan, the air fan will continue to run for about 60 – 120 seconds until the heat exchanger has been cooled down to a safe level.

To turn off the air heater for a short period, turn room

- a) thermostat to lowest setting.
- b) to relight reset thermostat.

To turn off the air heater for prolonged period;

- a) turn room thermostat to low setting or 'OFF' position
- b) shut off gas supply to the appliance
- c) switch off electricity supply to the air heater after air circulation fan has stopped.
- d) to relight follow lighting instructions.

The gas service tap must only be operated in emergencies, for servicing or prolonged periods of shutdown of the air heater.

9.3 Operation

In case of a not continuous running fan (= ventilation), simultaneously to the ignition circuit and gas valve circuit being energised, electrical power is supplied to a time delay relay that will activate the fan. The air circulation fan will start after about 20 à 60 seconds.

In the event of the combustion air volume falling below a safe level, the burner will be extinguished a re-start cycle will commence after adequate combustion air volume has been restored.

Figure 12 : Ignition system

The BSHH/BRHH heater is equipped with a direct spark integrated control relay. The control relay monitors the safety devices and controls the operation of the venter motor and the gas valve between heat cycles. The time line below illustrates a normal heat cycle.

The time line below illustrates a normal heat cycle.

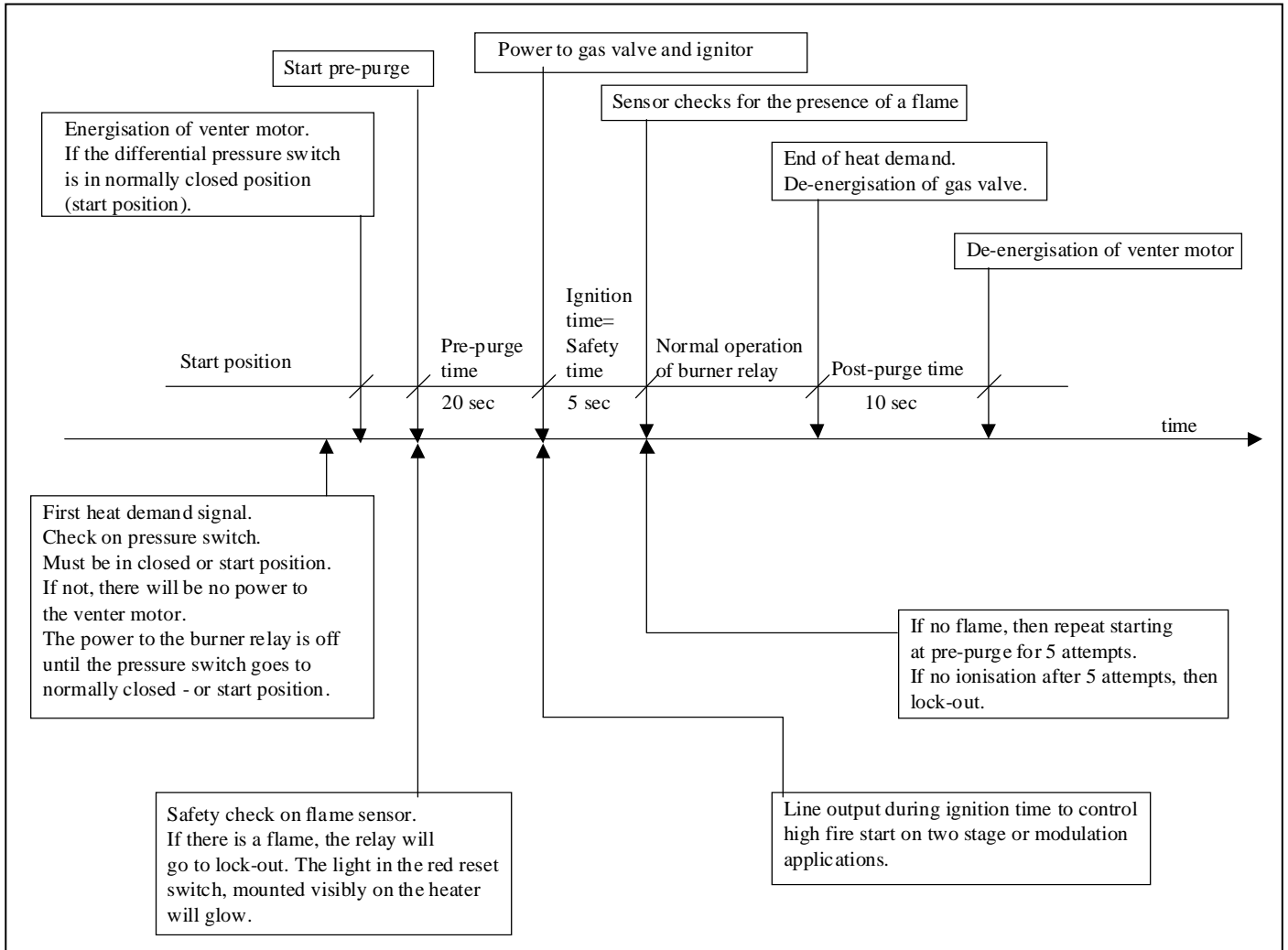

Definitions

- Start position: The system is not in lockout position and can proceed with the start-up sequence upon a demand for heat.
- Pre-purge time: This is a period of 20 seconds during which the combustion fan (venter) operates prior to activation of the ignition device.
- Safety time: The safety time is the delay between the gas valve being energized and the flame sensor checking for the presence of a flame. This is a period of 5 seconds.
Note: If no flame is sensed, the burner relay will **attempt ignition 5 times before going into lock-out mode.**
- Post-purge time: This is the time of 10 seconds between burner shutdown and the moment the combustion fan (venter) is de-energized.

9.4 Burner gas pressure adjustment

The gas pressure is set for the required heat input before the appliance leaves the factory. Provided that the gas supply to the air heater is in accordance with the supply pressure described on the appliance data plate, the operating pressure will not require adjustment.

To check the pressure use the following procedure:

- o Ascertain from the heater's data plate the correct operating gas pressure;
- o Turn the room thermostat control to its lowest setting;
- o Connect a manometer to the test point on the gas manifold;
- o Adjust the room thermostat to call for heat i.e. above room ambient temperature;

- o Observe the burner gas pressure on the manometer and compare to the required pressure on the data plate;
- o If necessary, adjust the burner gas pressure. Remove the cover screw. Turn the regulator screw anti-clockwise to decrease pressure or clockwise to increase pressure (see figure 13). Adjusting the burner pressure may only be carried out by suitably qualified persons.
- o Set room thermostat to lowest setting to turn OFF the burners. Replace the test point screw/cap and with the main burner OFF, test for gas soundness using a leak detector fluid.
Reset temperature control/room thermostat to comfort operating level.

Figure 13: Honeywell gas valve

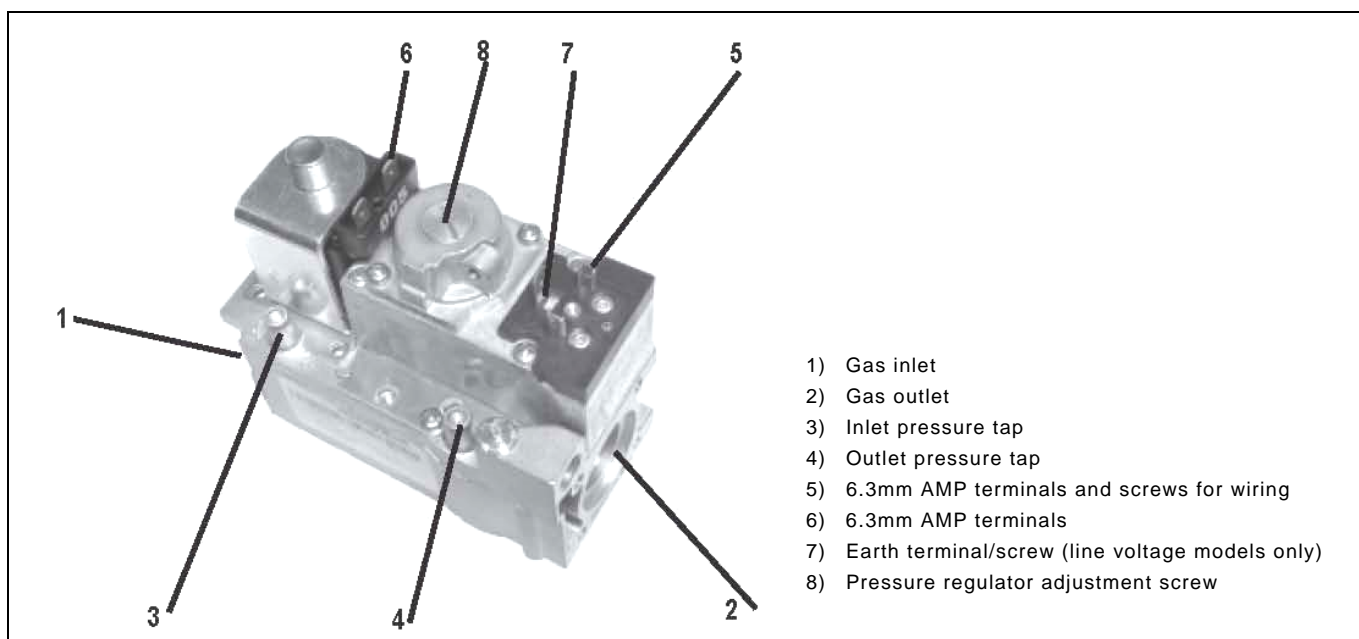

Table 5 : Burner jets and pressures

	BSHH/BRHH		055	083	102	
Nat Gas G20	Burner jet	dia	6,80	7,60	8,40	inlet pressure 20 mbar
	Burner pressure	mbar	8,30	10,40	8,80	
Prop Gas G31	Burner jet	dia	4,50	4,50	5,60	inlet pressure 37 mbar
	Burner pressure	mbar	15,70	34,36	23,50	

The BSHH/BRHH air heaters can be optionally equipped with two stage burners. The type of gas control fitted is the "Honeywell" VR 4601P/B or VR 4601A/B either are fitted with a two-stage pressure governor model V4336A. Regulation is possible for the pressure range 1,5 - 20 mbar for natural gas and 4 -37 mbar for propane gas. The appliances are fitted with a relay to ensure that during burner start-up the initial firing rate is 100% to ensure good burner cross lighting. Adjusting the burner pressure may only be carried out by suitably qualified persons.

Setting (refer to figure 14) :

Allow time for pressure to stabilise before and during making adjustments.

- Lever off the plastic cover cap
- Maximum high rate setting **must** be adjusted first after which the minimum low rate setting can be adjusted. Any adjustment of the maximum setting influences the minimum setting.
- Do not adjust maximum or minimum settings above or below the pressures stated on the air heater data plate.

Adjusting maximum pressure setting :

- Energise high/low regulator, set gas control in operation and wait until an outlet pressure is recorded on pressure gauge.
- Use a 10 mm screwdriver to turn adjustment screw for **maximum** pressure setting clockwise to increase and counter-clockwise to decrease pressure until desired maximum pressure is obtained.
- Check maximum pressure setting several times.

Adjusting minimum pressure setting :

- Disconnect electrical connection of high/low regulator.
- Set gas control in operation and wait until an outlet pressure is recorded on pressure gauge.
- If minimum pressure setting needs adjustment then use a 3.5 mm screwdriver to turn adjustment screw for **minimum** pressure setting, clockwise to increase or counter-clockwise to decrease pressure, until desired minimum pressure setting is obtained.
- Wire high/low regulator in circuit.
- Check **maximum** pressure setting, re-adjust if necessary and check minimum pressure again.

Figure 14 :

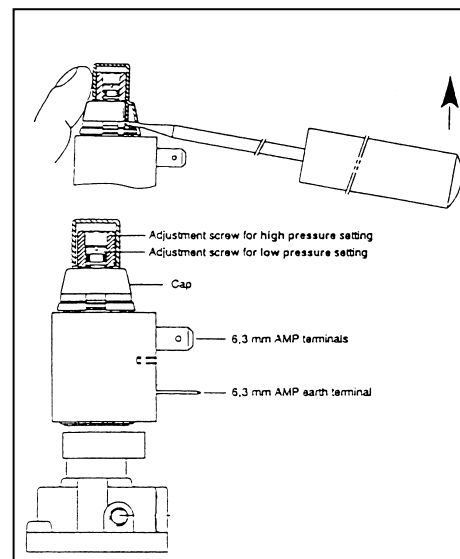

Table 6 : High/low burner gas pressures and low rate consumption values

		Model		055	083	102
Burner pressure	Pressure @ 100%	nat. G20	mbar	8,30	10,40	8,80
		prop. G31	mbar	15,70	34,26	23,50
	Pressure @ 50%	nat. G20	mbar	2,08	2,60	2,20
		prop. G31	mbar	3,92	8,59	5,87
Gas consumption @ 50% Ref. 15°C, 1013mbar (1)		nat. G20	m³/h	2,79	4,18	5,13
		prop. G31	kg/h	1,08	1,61	1,98

Note : burner pressures for propane gasses are approx. Based on regulated supply pressure

- (1) - nat gas G20 net calorific value 34,02 MJ/m³ @ 15°C & 1013 mbar
 - prop gas G31 net calorific value 88,00 MJ/m³ @ 15°C & 1013 mbar

Low fire rate must not be reduced below the values stated above for 50 % RATING

This air heater is designed to operate on natural, propane or butane gas and will be supplied as ordered for the gas type specified. In the event it is required to convert to a different gas type to that which has been supplied, conversion of the gas burner must be carried out. This can only be carried out by an appropriately qualified person current to IEE regulations

An approved conversion kit to suit the appropriate gas type must be used.

In addition to changing the burner injectors, and adjusting the burner gas pressure (pressure regulator or throttle adjusting screw), for sealing the governor or the throttle adjusting screw it is necessary to fix data plate over stickers as supplied with the conversion kit of parts (propane see figure 15).

After conversion re-commission appliance according to section 9 of this document.

Remark: Always check the propane gas quality, a too high percentage of butane can cause sooting of the heat exchanger.

Figure 15

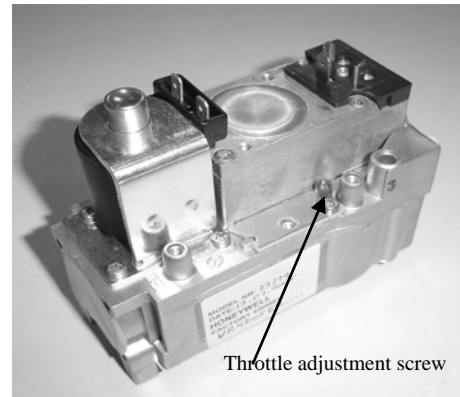

Table 7 : High/low burner gas pressures

Type				055	083	102
Natural gas G20	Injector dia (1x)		mm	6,80	7,60	8,90
	burner pressure	100%	mbar	8,30	10,40	8,80
	burner pressure	50%	mbar	2,08	2,60	2,20
Propane gas G31	Injector dia (1x)		mm	4,50	4,50	5,60
	burner pressure	100%	mbar	15,70	34,36	23,50
	burner pressure	50%	mbar	3,92	8,59	5,87

12.1 Maintenance schedule

General:

Before commencing servicing, turn off the main gas supply and switch off the main electricity supply after the air circulation fan has stopped.

The heater will operate with a minimum of maintenance. It is recommended that maintenance is carried out at least once a year by a suitably qualified person. More frequent servicing may be required dependent upon the environmental circumstances where the air heater is installed. Regular inspection is necessary, especially in dirty areas, to assess the servicing frequency.

Check condition and security of flue and combustion air system.
Check for security and worthiness of the suspension or mounting system.

Maintenance Schedule:

The following procedures should be carried out at least once each year (see figure 16).

- Clean all dirt, lint, and grease from the fan and motor.
- Check the heat exchanger and externally for evidence of physical damage.
- Check the burner for scale, dust, or lint accumulation. Clean if required.
- Check the vent or vent/combustion air system for soundness. Replace any parts that do not appear sound.
- Check the wiring for any damage. Replace damaged wiring.

Figure 16a : Location components BSHH/BRHH models

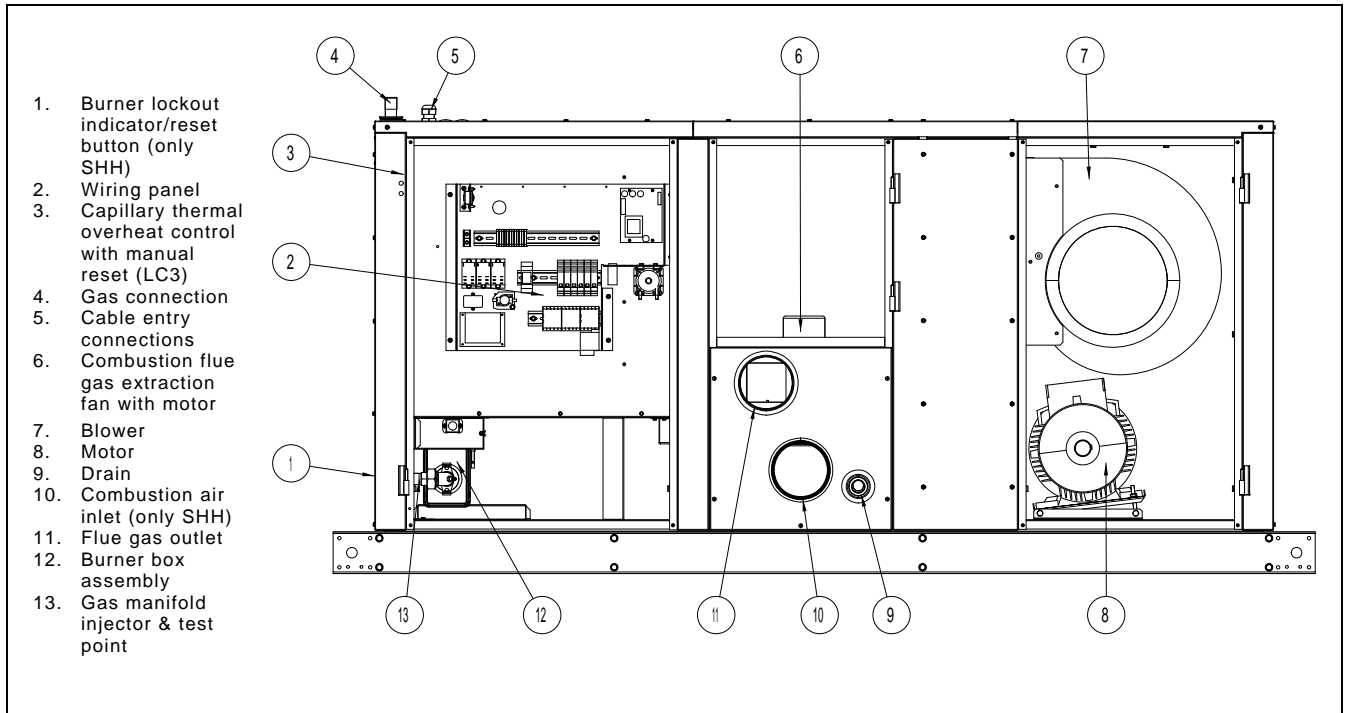
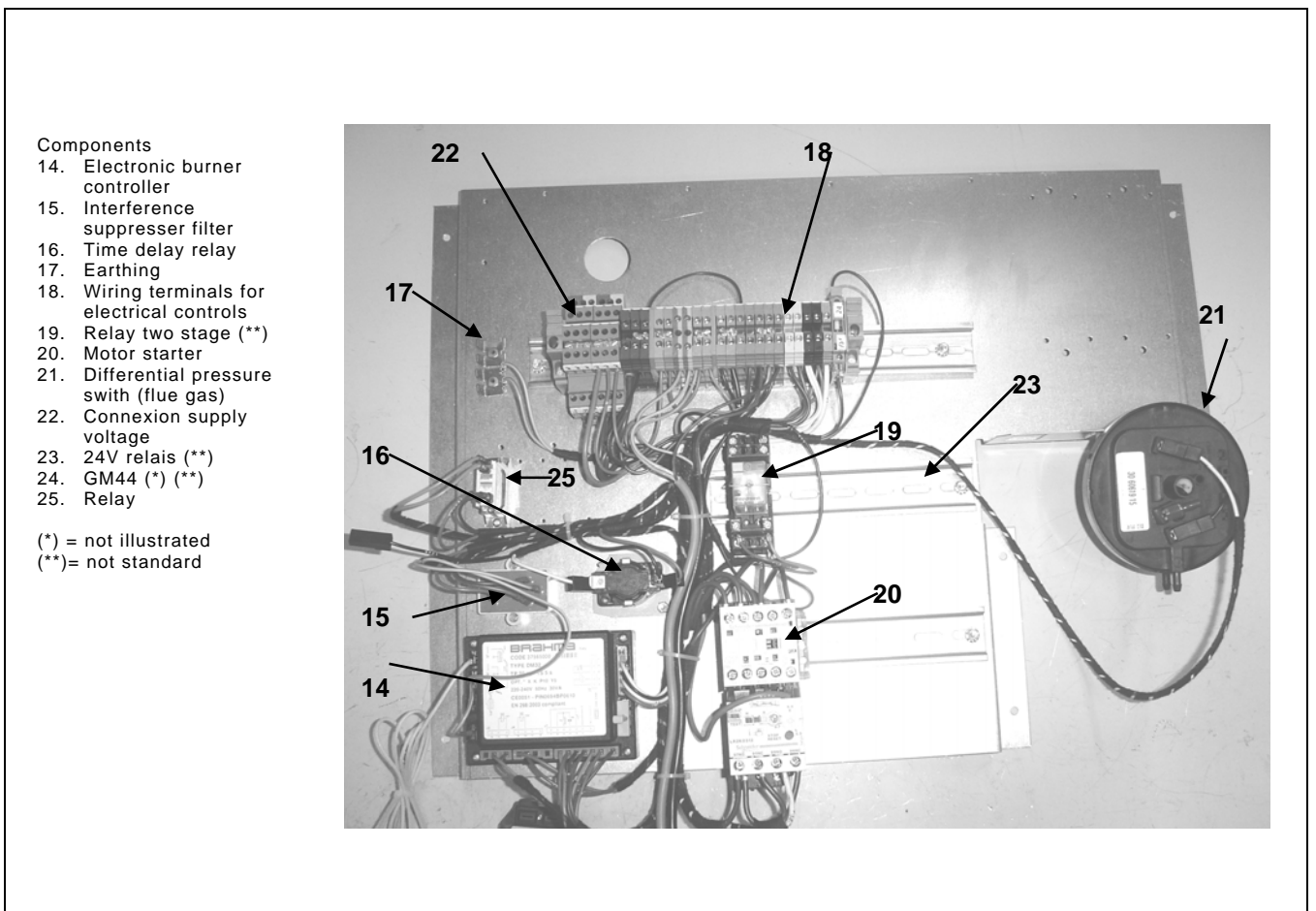

Figure 16b :Detail wiring panel



12.2 Heat exchanger maintenance

This heater is equipped with a T-CORE² heat exchanger. Remove any external dirt or dust accumulation. Visually check the heat exchanger for cracks and holes. If a crack or hole is observed, replace the heat exchanger.

A T-CORE² heat exchanger has a primary and secondary heat exchanger – check both sections.

12.3 Burner maintenance

This heater has a unique one-piece T-CORE² burner assembly designed to provide controlled flame stability without lifting or flashback. The burner can be removed as a unit for inspection or service : see below for removal instructions.

Inspect the burner/control compartment annually to determine if cleaning is necessary. If there is an accumulation of dirt, dust, and/or lint, clean the compartment and follow the instructions below to remove and clean the burner.



Use of eye protection is recommended.

12.3.1 Burner removal :

Instructions

1. Outside the cabinet, shut the gas supply off at the manual valve ahead of the union
2. Turn off the electric supply.
3. Disconnect the gas supply at the union outside of the cabinet.
4. Open the access door.
5. Remove burner :

Figure 17
Remove 2 screws of the burner shield

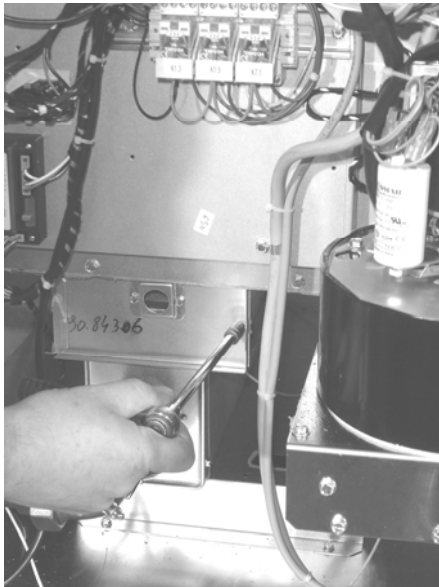

Figure 18

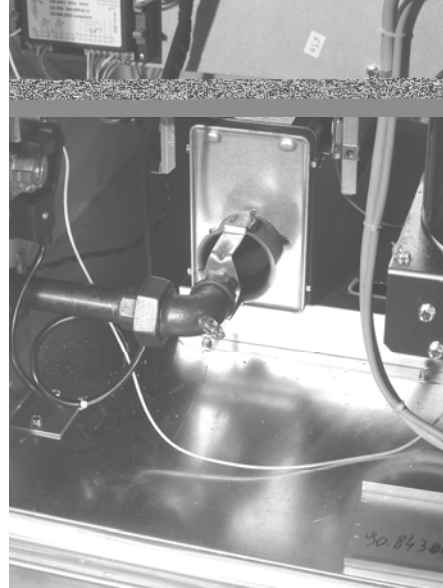

Figure 19
Disconnect gas manifold at the 90° elbow

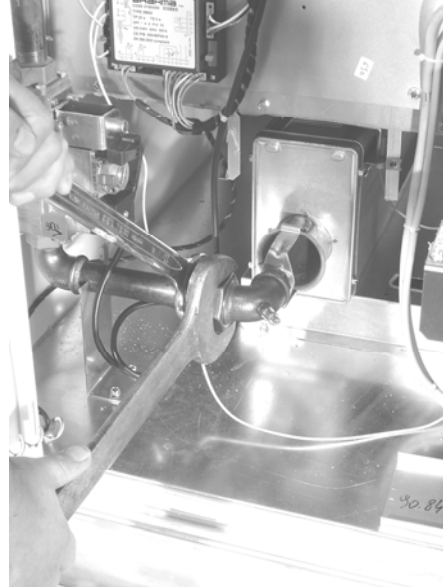

Figure 20
Gas manifold is split

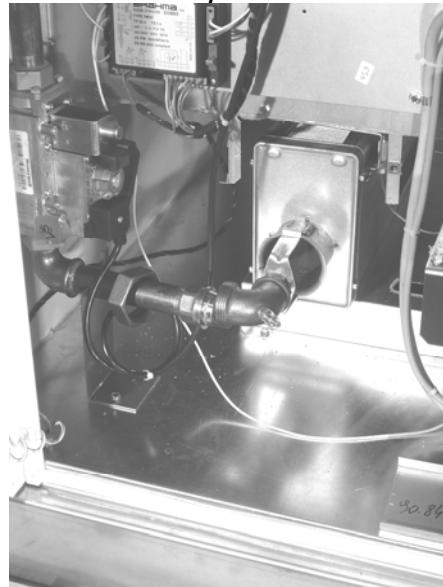

Figure 21
Remove 2 screws of the burner slider

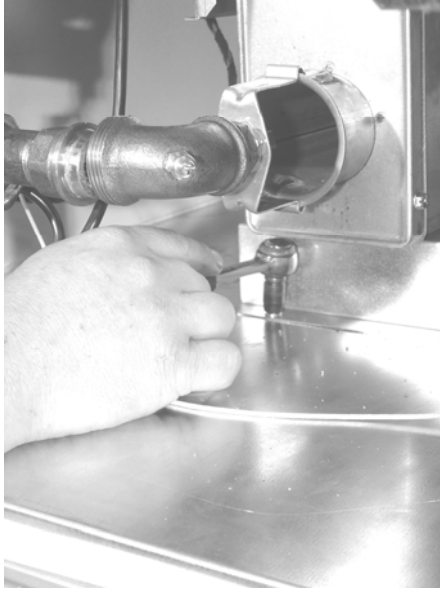

Figure 22
Disconnect wire of the ignition electrode at the burner controller



Figure 23
Disconnect flame sensor wire at the burner controller

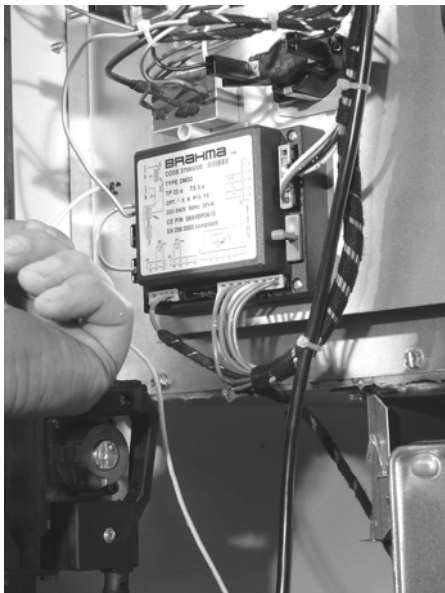

Figure 24
Remove burner box (together with flame sensor and ignition electrode)



12.3.2 Inspect and clean the burner :

With the burner assembly removed, shine a flashlight on the burner ribbons. Look for carbon buildup, scale, dust, lint, and/or anything that might restrict flow through the spaces between the burner ribbons. Holding the burner assembly so that any foreign material will fall away from the burner, use a stiff bristle brush to loosen and remove any foreign material(s). If the burner is excessively dirty, remove one of the burner end caps. Remove the four screws that hold the end cap to the burner housing. Lightly tap the end cap to remove it. Clean all foreign material from the burner and venturi. Use pressurized air to clean complete ribbon tray of the burner. After the burner is thoroughly clean, replace the end cap making sure that it is tight against the burner housing. NOTE: If any of the burner components are damaged or deteriorated, replace the burner assembly.

Figure 25

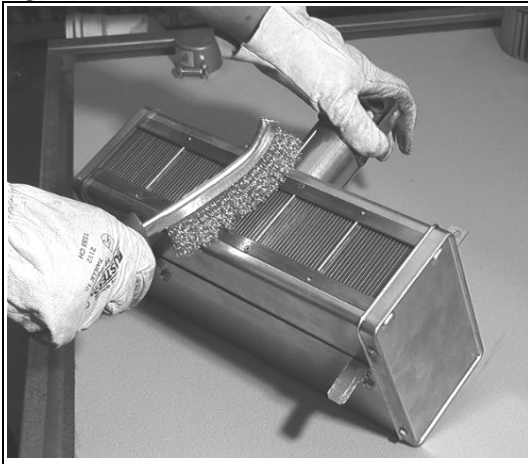

12.3.3 Reinstall the burner :

Repeat 'Burner Removal' steps above in the opposite order.

12.4 Burner orifice

The burner orifice normally needs to be replaced only when a change in gas is made. When ordering a replacement orifice, provide (MJ/m³) heating value and specific gravity of gas, as well as the model and serial number of the unit. When removing or replacing the burner orifice be careful not to damage the venturi tube and/or the bracket.

12.5 Ignition system

The igniter and flame sensor are fixed on the burner body. For replacement burner body needs to be removed (we herefor refer to section 11.3 : Burner maintenance).

Igniter - Refer to figure 16 and locate the igniter. Disconnect the wire; remove the screw and the igniter. Clean the igniter assembly with an emery cloth. Spark gap must be maintained to 3 mm. Important: When reassembling, the wire must remain attached to the igniter.

Flame sensor - Refer to figure 16 and locate the flame sensor. Disconnect the wire, remove the screw and the flame sensor. Clean with an emery cloth..

Figure 26 : Flame sensor



Figure 27 : Igniter

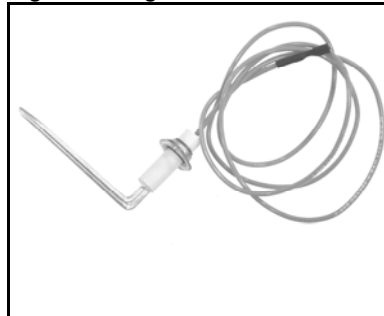

Figure 28 : Burner body



Control relay - See figure 29. The electronic burner relay monitors the operation of the heater including ignition. Do not open the control relay. Each heating season check the lead wires for insulation deterioration and good connections.

Proper operation of the direct spark ignition system requires a minimum flame signal of 1.0 microamps (DC) as measured by a microampmeter. For further information and check out procedure on the direct spark ignition system and the Troubleshooting Flow Chart.

Figure 29 : Control relay

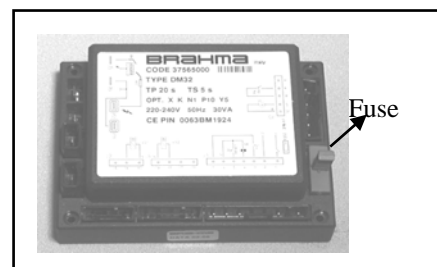

12.6 Fan motor, fan

The fan motor is equipped with thermal overload protection of the automatic reset type. Should the motor fail to run, it may be because of improper voltage characteristics. Make certain that the correct voltage is available at the motor.

Remove dirt and grease from the motor and the fan. Use care when cleaning the fan to prevent imbalance.

12.7 Venter motor & wheel

See figure 30

Remove dirt and grease from the motor casing, the venter housing, and the venter wheel. Venter motor bearings are permanently lubricated.

Follow these instructions for replacement of the venter motor and wheel assembly. Keep all hardware removed to be used in reassembling and installing the replacement parts.

1. Turn off the gas and disconnect the electric power.
2. Open the control compartment access door.
3. Disconnect the three venter motor wires at the terminal and ground screw .
4. Holding the motor, remove the screws that attach the motor plate to the venter housing. Remove the motor and wheel assembly from the heater.
5. Reassemble with the replacement venter motor and wheel assembly.
6. Follow the wiring diagram to properly connect the wires.
7. Restore power to the heater and turn on the gas. Light, following the instructions on the lighting instruction plate. Check for proper operation. Close the access door.

Figure 30 : EBM motor

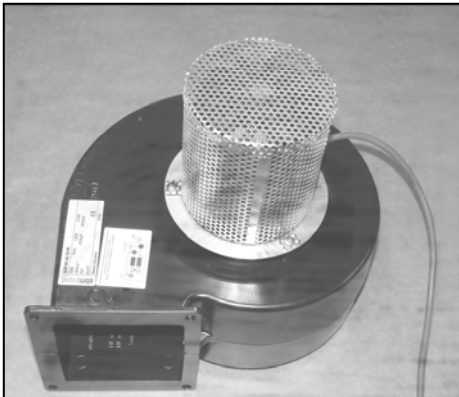

12.8 Operating gas valve

See figure 31

The main operating quick opening gas valve is powered through the thermostat and safety controls. The main control valve is of the diaphragm type providing regulated gas flow and is adjusted at the factory. The gas valve requires no field maintenance except careful removal of external dirt accumulation and checking of wiring connections. Instructions for testing pressure settings are in sections 9 and 10.

Figure 31 : Gas valve, (nat.gas))



12.9 Combustion air pressure switch



Safe operation of this unit requires proper venting flow. Never bypass the combustion air pressure switch or attempt to operate the unit without the venter operating.

The combustion air pressure switch ensures that proper combustion airflow is available. The switch senses the differential pressure between the negative pressure in the flue gas collector box and the pressure in the control section. (For switch location, see figure 16).

On startup when the heater is cold, the sensing pressure is at the most negative level, and as the heater and flue system warm up, the sensing pressure becomes less negative.

If a restriction or excessive flue pipe length causes the sensing pressure to be below the allowable level, the pressure switch will shut off the main burner.

If it is determined that the pressure switch needs replacing, use only the factory-authorized replacement part that is designed for the model and size of heater being serviced.

Figure 32 : pressure switch

055-102: PN 30 60618 420

083:PN 30 60617 300

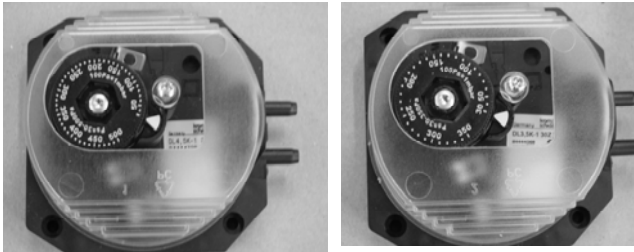

12.10 Limit controls



Never bypass the limit controls, hazardous conditions could result

All units are equipped with a temperature activated limit control. The control is factory set and non-adjustable. If either set point is reached, the limit control will interrupt the electric power to the gas valve. This safety device provides protection in the case of motor failure or lack of airflow due to restrictions (for location, see figure 16).

Figure 33



12.11 Fan delay relay

In case of a not continuous running fan, the fan delay relay will activate the blower fan motor maximum 60 seconds after the gas valve has opened. The fan will stop after maximum 120 seconds after the gas valve has shut down.

Figure 34 :

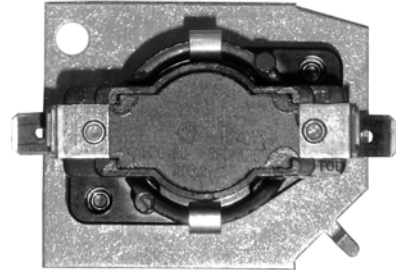

12.12 Flue and combustion air piping

Check the complete system at least once a year. Inspection should include all joints, seams, concentric adapters and the flue terminal cap. Replace any defective or heavily corroded parts.

12.13 Air filters

BSHH/BRHH units have an optional facility for air intake filters. Standard racks are provided to accommodate 50mm nominal thickness filter elements. Unless otherwise specified, filters supplied will be expendable type synthetic pleated elements. The sizes and quantities required to suit individual appliances are listed in table 8.

Table 8 : Filter size & quantities schedule

BSHH BRHH	Filter dimensions			Reznor PN
	Qty required	Length (mm)	Width (mm)	
055	4	496	395	60 61038 395496
083	4	496	395	60 61038 395496
102	2	624	496	60 61038 496624

12.14 Condense drain system

Check yearly the condensate disposal system. Remove the condensate trap and flush it with clean water to remove any deposit. Check that the piping to the sanitary drain has not been damaged. Verify that sanitary drain is not obstructed.

General troubleshooting

PROBLEM	PROBABLE CAUSE	REMEDY
Venter motor will not start	<ol style="list-style-type: none"> No power to unit. No power to venter motor. Integrated burner relay defective. Defective venter motor. Fluse blown (F3.1). Fuse burner relay blown. LC3 open. <ol style="list-style-type: none"> Unit in lock-out. Room thermostat open. 	<ol style="list-style-type: none"> Turn on power, check supply fuses or circuit breaker. Check connections at burner relay and/or venter motor terminals. Replace burner relay. Replace venter motor. Replace fuse. Replace fuse. <ol style="list-style-type: none"> Reset LC3. Replace LC3. Check if there is obstruction at the fan side. Push on reset button. Set thermostat above room temperature.
Burner will not light	<ol style="list-style-type: none"> Main valve not operating. <ol style="list-style-type: none"> Air in the gas line. Gas pressure too high or too low. <ol style="list-style-type: none"> No Spark: <ol style="list-style-type: none"> Loose wire connections. Incorrect spark gap. Spark cable has a short circuit to ground. Spark electrode has a short circuit to Burner relay not grounded. Unit not properly grounded. Faulty burner relay. <ol style="list-style-type: none"> Combustion air pressure switch not closing upon power to venter. 	<ol style="list-style-type: none"> <ol style="list-style-type: none"> Check voltage on valve during ignition period. Check connector on main gas valve. Check connector on burner relay. Replace valve. Purge gas line. <ol style="list-style-type: none"> Supply pressure should be 20 mbar for natural gas or 37 mbar for propane gas. Obstruction in the gas line. Gas line connection diameter too small. Check the following : <ol style="list-style-type: none"> Be certain all wire connections are solid. Maintain spark gap at 3 mm. Replace worn or grounded spark cable. Replace if ceramic spark electrode is cracked or grounded. Check burner relay ground wire. Make certain unit is properly field grounded (earthed) and properly phased (L1 to hot lead L2 to neutral). If voltage is available to the burner relay and all other causes have been eliminated, replace burner relay. First check the following : <ol style="list-style-type: none"> Make sure unit is properly vented. Remove obstructions from vent. Replace faulty tubing to pressure switch. Replace faulty pressure switch.
Burner cycle on and off	<ol style="list-style-type: none"> Gas pressure too high or too low. Burner relay not grounded. Faulty burner relay. Flame sensor grounded. Cracked ceramic at sensor. Incorrect polarity. 	<ol style="list-style-type: none"> Supply pressure should be 15 mbar for natural gas (UK only) or 37 mbar for propane gas. Check burner relay ground wire connection. If (220/240) volts is available to the burner relay and all other causes have been eliminated, replace burner relay. Be certain flame sensor lead is not grounded or insulation or ceramic is not cracked. Replace as required. Replace sensor. Check polarity and if necessary reverse line voltage wires to terminal block connections.
fan motor will not run	<ol style="list-style-type: none"> Circuit open. Defective fan time delay relay Defective motor. 	<ol style="list-style-type: none"> Check wiring and connections. Replace the time delay relay. Replace blower & motor.
Fan or venter motor turns on and off while burner is operating	<ol style="list-style-type: none"> Motor internal thermal protection device cycling on and off. 	<ol style="list-style-type: none"> Check motor load against motor rating plate. Replace motor if needed.

Flowchart

The integrated control relay monitors the operation of the heater. If the heater fails to operate properly, review the flow chart below and see the operating sequence in section 9. The general troubleshooting chart on the following pages will also help you to determine the problem.

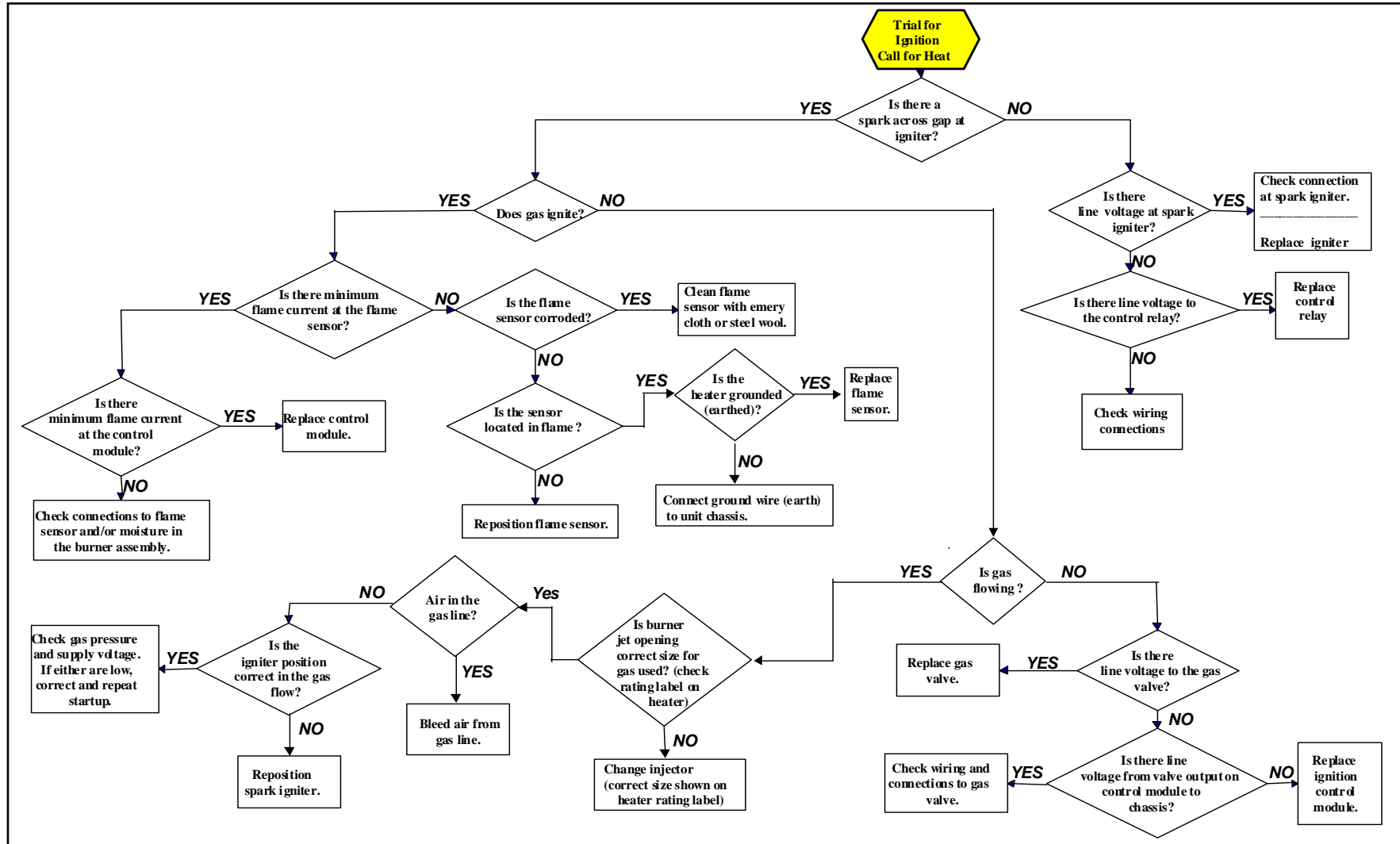

GAS SECTION		
Description	Part number	Application
Gas valve single stage burners nat. gas	03 25136	Natural gas
Gas valve single stage burners prop. gas	03 25265	Propane
Gas valve 2 stage burners nat. gas	03 25136 02	Natural gas
Gas valve 2 stage burners prop. gas	03 25136 02 (type 055)	Propane
Gas valve 2 stage burners prop. gas	03 35136 P437 (types 083/102)	Propane
Gas valve modulating burners nat. gas	03 35145	Natural gas
Gas valve modulating burners prop. gas	03 35145 (type 055)	Propane
Gas valve modulating burners prop. gas	03 35136 M337 (types 083/102)	Propane
ELECTRICAL SECTION		
Description	Part number	Application
Control relay	03 25322	All
Spark ignitor	05 25159	All
Flame sensor	05 25140	All
Fan control time delay relay	03 25167	All
Limit control LC3	03 24959 01	083/102
Limit control LC3	03 24959 02	055
Pressure switch	30 60618 420	055/102
Pressure switch	30 60617 300	083
Reset switch/burner fail lamp	60 61988	All
Suppresser filter	30 61747	All
Combustion fan motor	20 25745 01	All
Main wiring assembly 1-stage	06 41660	All
Wiring assembly 2-stage	06 41662	All
Relay 2 stage	30 61736 230V	All
AIR HANDLING SECTION		
Description	Part number	Application
Centrifugal blower	02 25749 02	055
Centrifugal blower	02 25749 04	083/102
MISCELLANEOUS		
Description	Part number	Application
Silicon tubing	06 20224 CM	All
Differential pressure switch, air flow proving & or clean filter control	30 60617	All
Air filters	60 61038 395496	See table 7
Air filters	60 61038 496624	See table 7

 Always quote model size/type & serial number when ordering spares!

15.1 Operating:

How the air heater works:

Gas is burned by an atmospheric burner which fires into a heat exchanger. The gas burner is controlled by a double gas valve via an electronic burner control, which is actuated automatically via external controls i.e. a room thermostat and/or a time switch. The burner is ignited by a spark igniter. When the burner fires and warms the heat exchanger, a time delay relay is activated and switches on the fan after maximum 60 seconds.

At the end of a heating cycle the burner is switched off, the air circulation fan will continue to run until 120 seconds after heat demand. Thereafter the fan will remain off until the next cycle is initiated.

Safety:

1. Flame failure is detected by the flame sensor which will immediately result in gas valve shut down.
2. Safety against overheating is assured by a overheat control. This is a control that locks out and switches off the burner in the event of gross overheating for any reason. Manual intervention is necessary to reset this control device. Resetting of the automatic burner control may also be required.
3. The location of the air heater should be maintained at normal atmospheric pressure. Changes to the building after air heater installation, should have regard to the heating installation, i.e. structural changes causing excessive draughts from doors, windows etc. Other air handlers and installation of air extraction equipment, which may cause a negative pressure environment, can seriously affect the operation of this type of air heater, especially if combustion air supply is not ducted.

15.2 To light the heater

1. Switch on the electricity supply to the air heater.
2. Turn on the gas supply to the air heater.
3. Ensure time switch (if fitted) is set to a 'ON' cycle.
4. Adjust control/room thermostat to desired temperature.
5. Air heater will light automatically when the room thermostat calls for heat.
6. If the appliance does not light:
 - a) check if the burner control does not require resetting. An indicator light glows at the front panel of the appliance and on a remote control (if fitted). Reset by pushing light/button on appliance or the remote control.
 - b) check if thermal overheat control requires resetting
7. If the thermal overheat control requires resetting and doing so restarts the air heater, wait until the appliance warms to thermal equilibrium, to ensure the overheat control does not lock out again. **If it does and the temperature near the heater is less than 30°C, then switch off the appliance and call for service.** If the temperature is over 30°C, take appropriate action to reduce the ambient temperature near the air heater.

15.3 Air circulation:

1. The space heating process is for air to be circulated through the appliance whereby it gains heat from a heat exchanger. The air is directly discharged into the space to be heated. The air is eventually recirculated. Therefore it is very important that an unobstructed path for the circulation of the air will be maintained. This is particularly important if the air heater has been installed to blow through the wall between two rooms.
2. Sometimes the air circulation fan of the appliance is connected to a remote over-ride switch. This enables cool air to be used for circulation purposes when the air heater is not used for heating purposes e.g. in summer. To use this feature:
 - a) switch ON electricity
 - b) switch ON manual override switch, this may be fitted as a feature on a remote composite control.

15.4 Maintenance

1. Maintenance and service must only be carried out by appropriately qualified persons e.g. "Corgi" registered undertakings.
2. It is in your interest to ensure proper service and maintenance is carried out at a regular basis. Periods between service are dependent upon the local environment where the heater is installed. All gas appliances should be serviced at least once a year.
3. In case of any damage to the appliance, it must be shut down completely and checked by an appropriately qualified person.
4. In the event of difficulties in resolving any of these matters, please do not hesitate to contact AmbiRad or their official distributor.

NORTEK GLOBAL HVAC (UK) LTD

Fens Pool Avenue
Brierley Hill
West Midlands DY5 1QA
United Kingdom

Tel. **01384 489 250**

www.ambirad.co.uk



Registered in England N° 1390934. Registered office: 10 Norwich Street, London, EC4A 18D

Nortek Global HVAC is a registered trademark of Nortek Global HVAC Limited. Because of continuous product innovation. Nortek Global HVAC reserves the right to change product specification without due notice