

ACR MINI SERIES

ACR MINI3, ACR MINI4-5, ACR MINI6

INSTALLATION AND OPERATING MANUAL

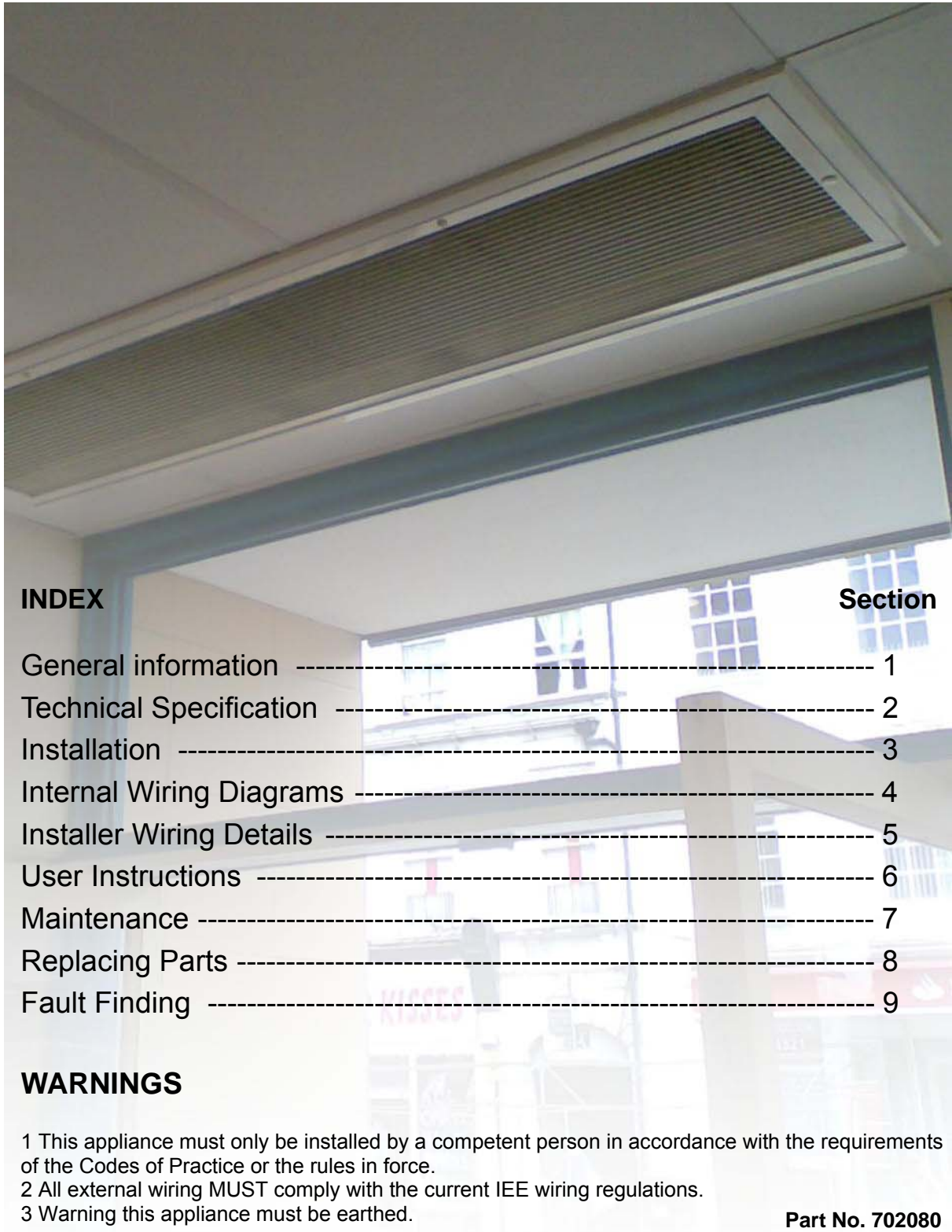

INDEX

Section

General information -----	1
Technical Specification -----	2
Installation -----	3
Internal Wiring Diagrams -----	4
Installer Wiring Details -----	5
User Instructions -----	6
Maintenance -----	7
Replacing Parts -----	8
Fault Finding -----	9

WARNINGS

- 1 This appliance must only be installed by a competent person in accordance with the requirements of the Codes of Practice or the rules in force.
- 2 All external wiring MUST comply with the current IEE wiring regulations.
- 3 Warning this appliance must be earthed.

1. General Information.

1.1 Models

These units are 600mm (3kW & 4.5kW models) and 900mm (6kW model) modular recessed heaters designed for mounting above doorways and similar entrances. They will fit directly into a 600 mm or 900mm modular grid in a suspended ceiling.

They may also be used as space heaters. (Minimum ceiling height of 2.2m, maximum height 2.8m).

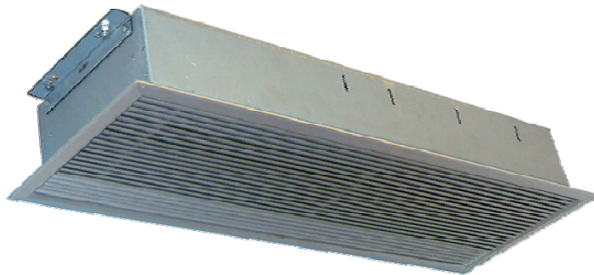

1.2 General

All installations must be in accordance with the regulations in force in the country of use.

These instructions must be handed to the user on completion of the installation.

Installers and service engineers must be able to demonstrate competence and be suitably qualified in accordance with the regulations in force in the country of use.

To ensure continued and safe operation it is recommended that the appliance is serviced annually.

The manufacturer, offers a maintenance service. Details are available on request.

1.3 Electrical

This unit is suitable for connection to a 230 50Hz single phase AC supply.

The heaters consume 3kW, 4.5kW and 6kW respectively when switched to the full heat position.

Units should only be wired by a competent electrician in accordance with the latest edition of the IEE wiring regulations. Ensure that the supply cables and circuit breakers are sufficient for the air curtain being installed.

The appliance should be connected to the supply via a two pole isolator.

To gain access to electrical connections the

recessed grille must be removed. The grille is secured to the enclosure of the air curtain via 4 cross head screws – see Figure 1.(Installation section) Cable entry may be moved to alternative position if desired.

Warning

For safety reasons a good earth connection must ALWAYS be made to the heater and control box.

1.4 Mounting

When fitting ensure that the air discharge is situated as close to the door as possible. The recessed air curtains are designed to fit directly into any suspended ceiling, especially ceiling tile grid formation. If the grid does not align with the door then it will need modifying.

The unit should be mounted so that the airflow is not obstructed by any part of the doorframe.

1.5 Health and Safety

Sole liability rests with the installer to ensure that all site safety procedures are adhered to during installation.

Sole liability rests with the installer to ensure that protective safety wear such as hand, eye, ear and head protection is used during installation of the product.

Do not rest anything especially ladders against the product.



WARNING:

THIS HEATER SHOULD NOT BE INSTALLED WHERE THERE IS A CORROSIVE ATMOSPHERE.

2. Technical Specification.

		ACR Mini3	ACR mini4.5	ACR mini6
General Data				
Maximum height	M	2.8		
Minimum height	M	2.2		
Heat medium		Electrically heated		
Maximum heat capacity	kW	3.0	4.5	6.0
Heat setting (switchbox versions)	kW	1.0/2.0/3.0	1.5/3.0/4.5	2.0/4.0/6.0
Heat setting (wireless versions)		Variable		
Fan type		Crossflow		
Fan dia	mm	60		
Fan settings		1		
Air outlet		Fixed vent		
Switching type		Remote switchbox/Wireless controller		
Weight	kg	9.5		14
Electrical Data				
Maximum heat capacity	kW	3.0	4.5	6.0
Supply voltage		230V 1ph 50Hz		
Total load	amps	13	20	27
Cable size		2 x 2.5mm ² + E	2 x 4.0mm ² + E	
External fuse size amps	amps	16	25	32
Switch box wiring		2 x 2.5mm ² + E	2 x 4.0mm ² + E	
Mains terminal block position		Inside cover		
Control terminal block position		Inside cover		
Air Data				
Fan setting		1		
Airflow	l/s	50	60	120
Noise level	dBA	44	52	
Dims Data				
Length	mm	nom 600	nom 900	
Depth	mm	nom 140		

3. Installation.

3.1 3 & 4.5 kW

To install the unit first remove the unit grille, see figure 1. (The control switch box is packed inside the unit. Remove the switch control box and retain for future 'Electrical Connection'.)

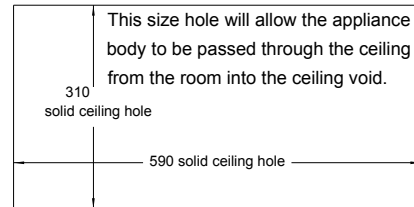
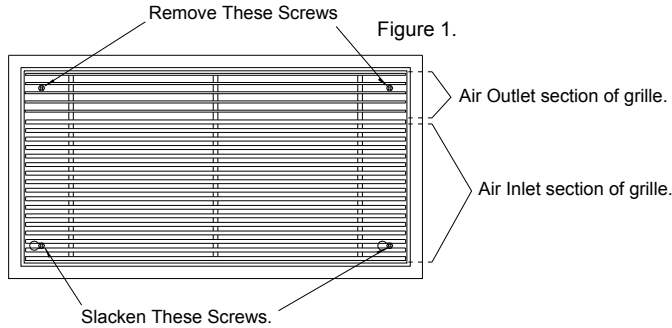

Slide grille sideways until grille keyhole slots pass over screw heads and grille can be removed from unit. An EARTH lead is connected to the grille from the unit body, push on connection at grille. When replacing the grille onto the unit ensure the EARTH lead is re-connected.

Each unit has 2 fixing brackets, see figure 3 and figure 4, from which it is suspended. Suspend the unit by threaded rod, chain or wire ties (rod, chain or wire ties are not supplied with the unit). The unit must be suspended from a structure of sufficient strength to support the unit weight.

Wire tie suspension is best achieved by using the smaller holes in the fixing brackets.

Chain suspension could use either the smaller or middle size holes.

Threaded rod suspension: Use the notches in the fixing brackets. An additional pair of locking plates are provided for use with threaded rod suspension. These locking plates should be positioned beneath each fixing bracket to prevent the suspension rods moving. Ensure that the locking nuts are fitted to stop the threaded rod from rotating loose. Before finally replacing the grille, ensure the protective film is removed.

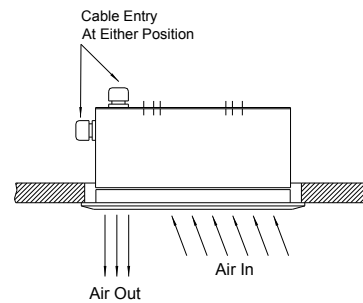
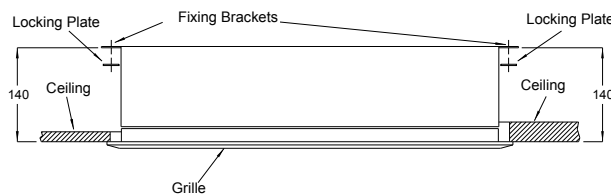
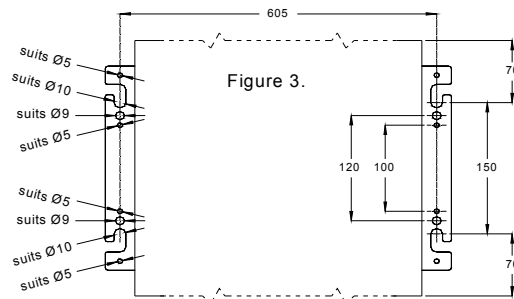
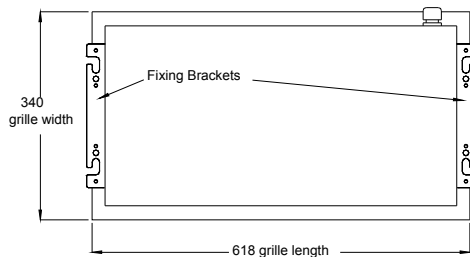

3. Installation cont.

3.2 6kW

To install the unit first remove the unit grille, see figure 1. (The control switch box is packed inside the unit. Remove the switch control box and retain for future 'Electrical Connection')

If mounted above a door the unit should be installed so that the outlet grille is nearest the doorway (directional arrows shown inside unit).

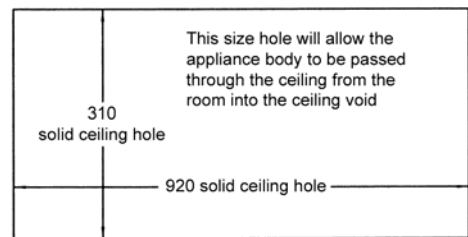
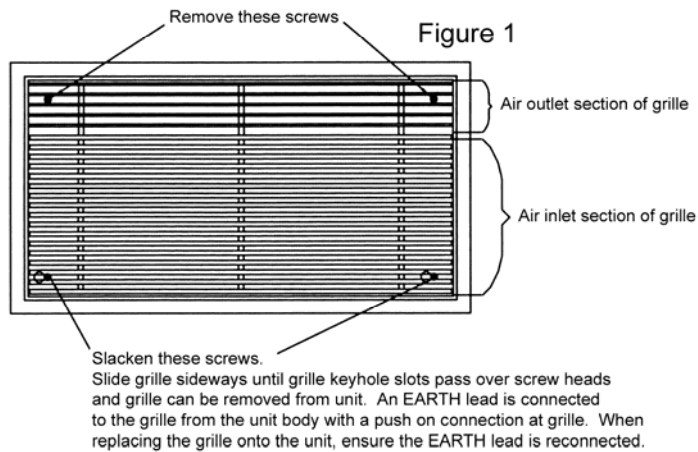

Figure 2

Each unit has 2 fixing brackets, see figures 3 and 4, from which it is suspended. Suspend the unit by threaded rod, chain or wire ties (rod, chain or wire ties are not supplied with the unit). The unit must be suspended from a structure of sufficient strength to support its weight.

Wire tie suspension is best achieved by using the smaller holes in the fixing brackets.

Chain suspension could use either the smaller or middle size holes.

Thread rod suspension: use the notches in the fixing brackets. An additional pair of locking plates are provided for use with threaded rod suspension. These locking plates should be positioned beneath each fixing bracket to prevent the suspension rods moving. Ensure that the locking nuts are fitted to stop the threaded rod from rotating loose. Before finally replacing the grille, ensure the protective film is removed.

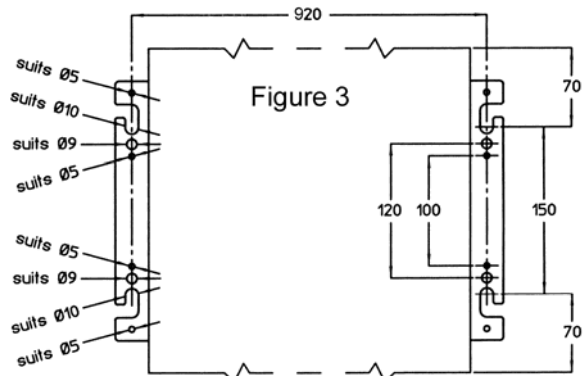
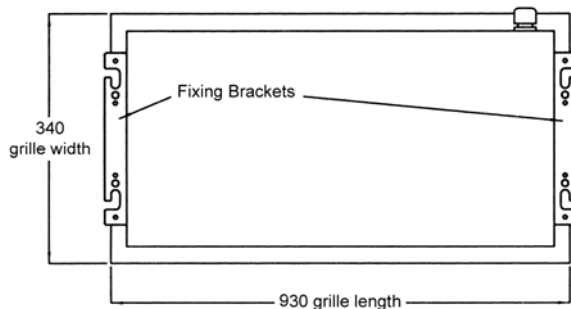
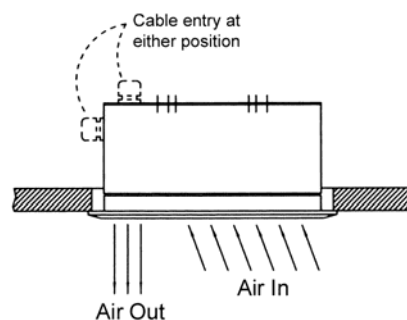
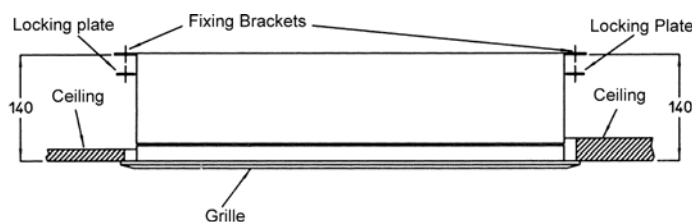
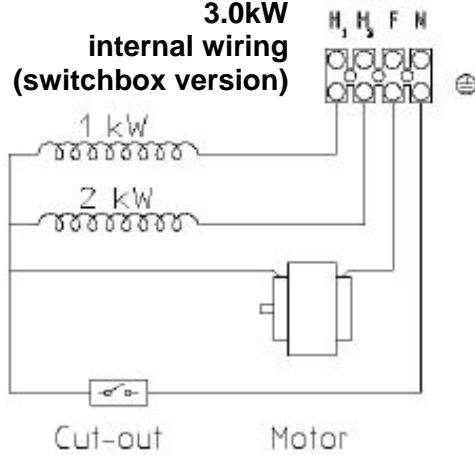

Figure 4.



4. Internal Wiring Diagrams.

**Figure 1. ACR MINI 600SE3
3.0kW
internal wiring
(switchbox version)**



**Figure 2. ACR MINI 800SE4-5
4.5kW
internal wiring
(switchbox version)**

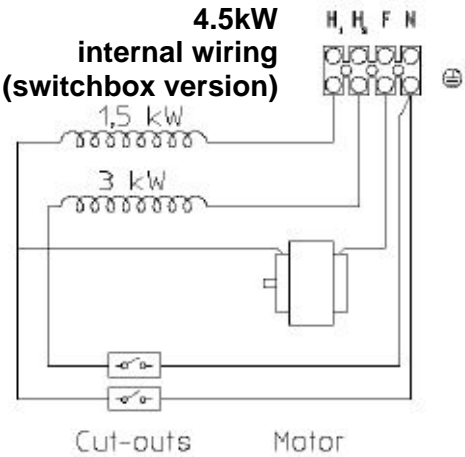

**Figure 3. ACR MINI 1000SE6
6kW
internal wiring
(switchbox version)**

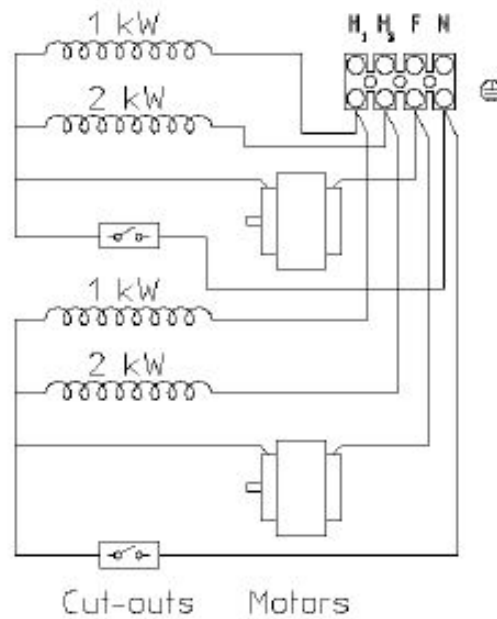

Figure 4. ACR MINI 600SE3 3.0kW Wireless internal wiring.

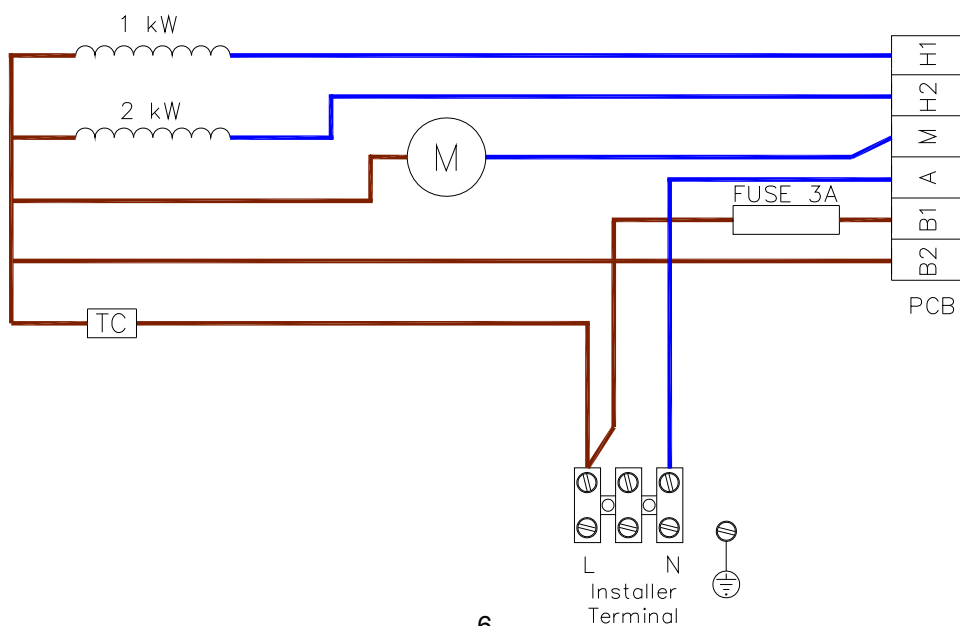

Figure 5. ACR MINI 800SE4-5 4.5kW Wireless internal wiring

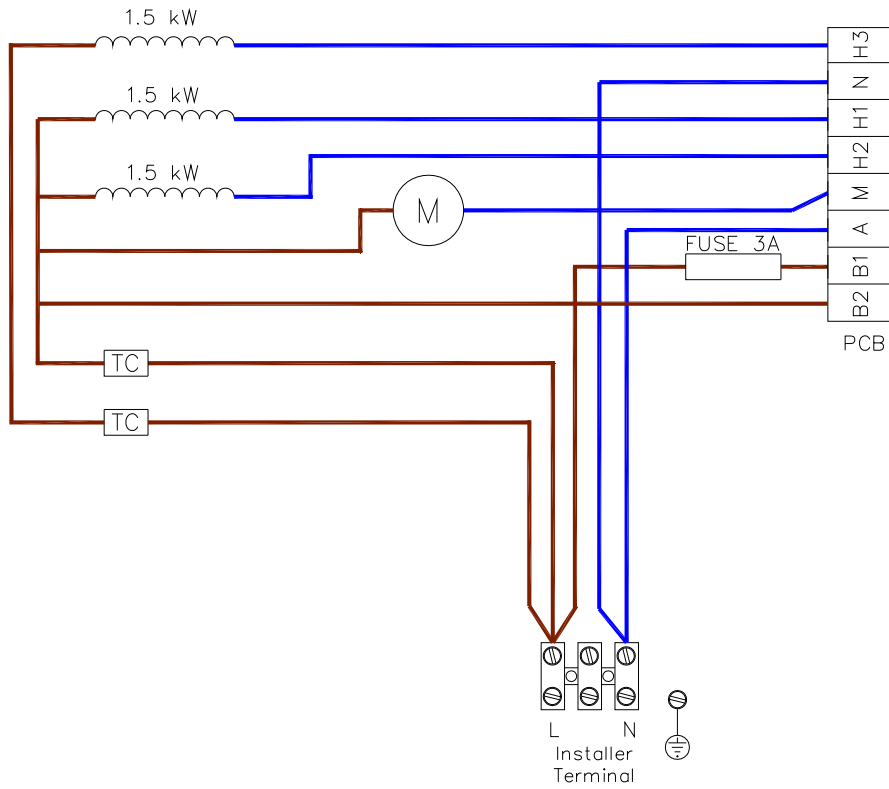
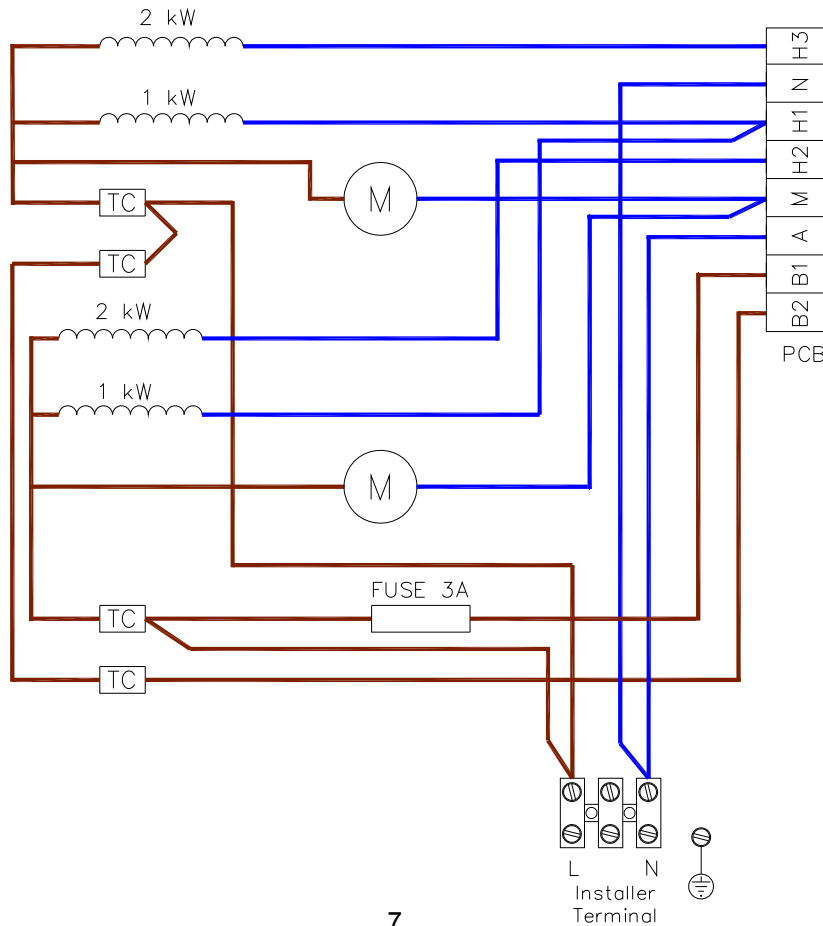

Figure 6. MINI 1000SE6 6.0kW Wireless internal wiring



5. Installer Wiring Details.

Switch box versions

Figure 7.



Figure 8.

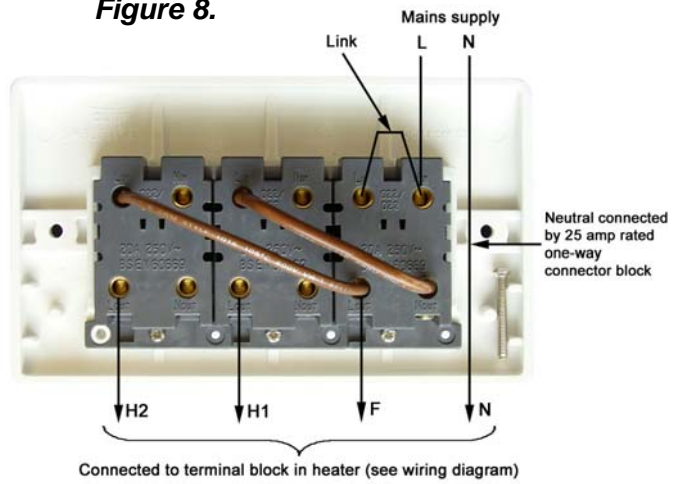

Wireless versions

Figure 8.



These units do NOT have a switch box. Connection to the mains supply is made direct to a 3 way connector block inside the unit.

6. User Instructions.

6.1 Controls

All units are supplied with a remote switch that gives the following functions; on/off plus two heat settings. Optional wireless control versions are also available.

For thermostatic control a room thermostat maybe connected.

6.2 Switchbox versions.

To switch on the appliance and operate the blower, depress the left-hand switch (marked "FAN").

When the centre switch only (marked with a single bar) is depressed the heat output is $\frac{1}{3}$ of full heat. When the right hand switch only (marked with a double bar) is depressed the heat output is $\frac{2}{3}$ of full heat. When both the centre switch and the right-hand switch are depressed full heat output is available.

6.3 Wireless remote control versions

The controller is a wireless (433MHz) thermostat giving high precision room temperature control. It is also a seven day programmer with up to six temperature settings per day. Each controller can control any number of heaters.

6.4 Batteries

Remove the controller battery cover and insert 2 new high quality alkaline AA batteries.

WARNING

The manufacturer is not responsible for damage due to corrosion. Battery leakage will cause permanent damage. To help avoid this:

- Replace the batteries annually, even if there is not a low battery warning. Remove failing or flat batteries immediately.
- Always fit a pair of new high quality alkaline batteries from the same pack. Never mix new and old batteries, or batteries of different brands or types.
- Never attempt to revive alkaline batteries by heating, or recharging.

You must reset the clock after replacing the batteries, all other settings are unaffected.

6.5 Making wireless connection

This has to be done or the heater will not operate.

- Switch the heater's mains supply off.
- Switch it on for 3 seconds, then off again.
- Switch it back on. The green light on the heater should be flashing, if not repeat the procedure.
- You now have half a minute to press the button on the back of the controller. Once pressed the light on the heater will stop flashing and possibly change to yellow or red depending on the controller settings and the room temperature.

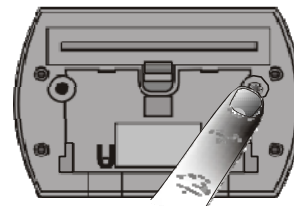

Button on rear of controller

This should not need to be repeated unless more heaters are added to the controller.

6.6 Choose position in the room

The controller should be positioned on a wall in the same room as the heater.

Avoid mounting in the following places:

- Draughty areas near windows, doors or vents.
- Near the heater itself or any other heat sources.
- In direct sunlight.
- Where it could be hit by a door.
- Where any moisture is present.

Before permanently fixing the controller in the chosen position then use to ▲ show power bars  (see quick adjust for more details).

Ensure heater turns on, if not consider another position.

6.7 Fixing controller to wall

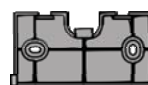

Remove the wall plate from the rear of the controller and mark through the screw holes (60mm centres). Drill and plug the wall to accept No. 6 or 8 screws and mount the wall plate. Clip the controller back on to the wall plate.

6.8 Heater control light

The control light can show 3 colours which are:

- Green when no heat is needed.
- Yellow when some heat is needed to maintain room temperature.
- Red when the heater is on full power.

The controller sends a radio signal every minute. When the heater receives the signal, the light turns off briefly and may change colour. When the heater is switched on, the light is always green until the first signal.

A slow flashing green light (every 1.6 seconds) means that, for 5 minutes no radio signals have been received. Follow the steps in 'Making wireless connection' to fix this.

A fast flashing red light (every 0.5 seconds) means the heater has overheated. Make sure the air flow is not restricted, switch heater off and allow to cool before switching on again.

6.9 Manual Control

(Heater not operated from controller)

To set manual control:

- If the heater is on, switch it off.
- Switch it on for three seconds then off again.
- Do this 5 times and your heater will be in manual control.
- To re-enable the controller, make a new wireless connection as described earlier.

In manual control, simply switch the heater on and off at its mains supply.

6.10 Cleaning the controller

Clean the controller with a soft lint-free cloth. Avoid getting moisture on the buttons or openings. Do not use sprays, liquids or abrasives.

6.11 Engineers settings

Time, Day and Program

Displays current time and day. Prog shows current program step.

Holiday (no program)

Switches the program off during holiday. Use ▲ ▼ to alter temperature. Choose - - - : no heating. 4°C : frost protection, or anything up to 12°C. These are set until

Timed boost

Press boost once to turn on for 15 min. Press again to add 15 min (up to 4 hrs. max). Use ▲ ▼ to adjust temperature. Boost ends when time elapsed or CLEAR is pressed.

Power and transmit signals

As the room reaches target temperature, heating is reduced from 100% (4 bars) to 0% (no bars).



The radio transmit symbol  appears when the controller transmits to the heater. This happens about once per minute.

Locking the controller

The controller can be locked to prevent tampering. When locked all buttons are disabled. HOLIDAY, BOOST, SET-BACK, ADVANCE, ▲ and ▼ are not displayed. To lock press SET-BACK and ADVANCE together, then press button on rear for 2 seconds. To unlock press SET-BACK and ADVANCE together, release them, then press button on rear within 2 seconds.

Quick adjust

Use ▲ ▼ to alter temperature. This reverts to set point in next program. If CLEAR is pressed it can be set to - - - : no heating, or anything between 4-30°C.

Continuous fan

If ▲ ▼ are pressed together the fan will operate regardless of the heat setting. This reverts to set point in next program or if CLEAR is pressed.

Advance

This brings forward the next program. Stays advanced until normal program time or CLEAR is pressed.

Set-back (economy)

The 7 day program continues to run, but temperatures, (except frost), are lowered by 5°C. Continues until CLEAR is pressed.

Actual and target temperatures

Actual is current room temperature, target is the desired temperature. Target is set manually or by the program and can be displayed as - - - when no heating required.



Setting the time and day

To set the clock press HOLIDAY and BOOST together. The hour will start to flash and can be adjusted with ▲ ▼ Using SELECT adjust minutes, day of the week or change between 24 and 12 hour clock. When finished press OK.

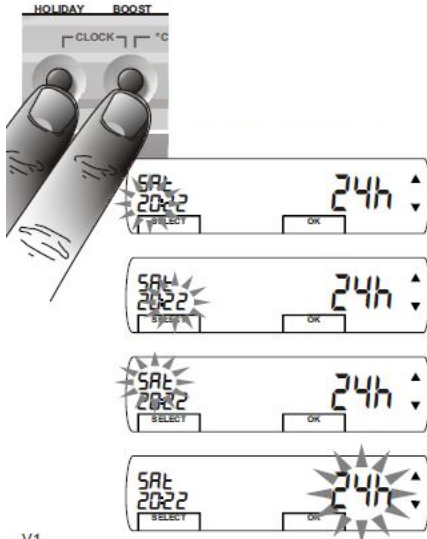

Celsius or Fahrenheit

Pressing BOOST and SET-BACK together changes actual and target temperatures from Celsius to Fahrenheit.

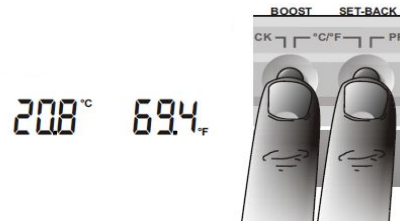

Setting the 7 day program

To set a program press SET-BACK and ADVANCE together. This will take you to stage 1 below. Program times cannot overlap.

Note: should the unit accidentally lock while setting a program, see 'Locking the controller' section.



- The program number and day will flash. Change using ▲ ▼ SELECT goes to stage 2.

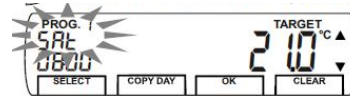

- The time flashes. Adjust using ▲ ▼ SELECT goes to stage 3.

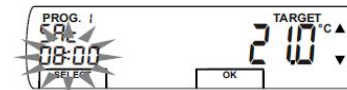

- The temperature flashes. Adjust using ▲ ▼ for room temperature, 4°C (frost protection) or --- (no heating)

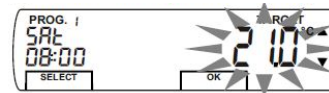

- When programming has finished, press OK to return to normal operation.

Factory set program

Program	Mon to Fri	Sat and Sun
1	06:30 2 1.0°C	08:00 2 1.0°C
2	08:30 4.0°C	23:00 4.0°C
3	16:30 2 1.0°C	---:-- ---:--
4	23:00 4.0°C	---:-- ---:--
5	---:-- ---:--	---:-- ---:--
6	---:-- ---:--	---:-- ---:--

Each weekday is 21°C from 6.30 to 8.30am, then 4°C until 4.30pm, then 21°C until 11.00pm, then finally 4°C until program 1 on the next day. To restore this program press ▲ ▼ together during 'copy day' in 'Setting the 7 day program'.

Frost protection 4°C



Set target temperature to 4°C. For no frost protection set to ---. The snowflake symbol appears if the actual temperature falls below 4°C.

Continuous fan

While temperature is flashing press ▲ ▼ together to choose continuous fan for current program.

Manual operation

If all 6 programs in all 7 days are cleared, then the temperature control is done by Quick adjust.

Clearing a program

From stage 1 press CLEAR to clear a program, or press again to un-clear a program.

A cleared program displays as --:-- , °C, and the program is ignored.

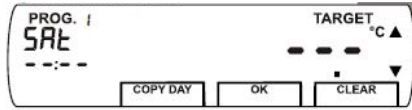

Copy day

This copies all 6 programs from the day being programmed to another day. Press COPY DAY to do the copy. CLEAR will return to stage 1.

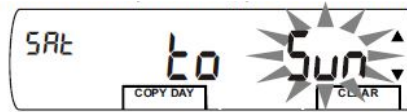

7. Maintenance.

! ALWAYS ENSURE THAT THE ELECTRICITY SUPPLY IS SWITCHED OFF BEFORE COMENCING WORK ON THIS HEATER.

To obtain best results from your heater, the build up of dust and dirt within the unit and on

the air inlet /discharge grilles should be avoided . For this reason regular cleaning is necessary, paying particular attention to the removal of dirt build up on the rotor blades. A single drop of light oil should be applied to the motor bearing from time to time.

8. Replacing Parts.

8.1 To replace the fan heater assembly

- Remove the grille.
- Disconnect the internal wiring from the main terminal block.
- Remove the four nuts and washers fixing the fan heater assembly to the back of the case.
- The fan heater assembly can now be eased forward and removed from the heater case.
- Fit replacement fan heater and reassemble in reverse order.

8.2 Spares

It is essential when ordering spares or replacement parts to state the model number and the serial number on the rating plate fixed to the top of the unit.

In the interest of progress the Company reserve the right to vary specifications from time to time without prior notice. The material listed is offered subject to the general conditions of sale, a copy of which can be obtained on request.

The company offer a service facility, call 01384 489700. Servicing should be undertaken by a competent person.

9. Fault Finding.

9.1 Protection

(Thermal cut-out)

The units are protected from overheating in the event of fan failure or an obstruction of the free airflow, by auto resetting thermal cut outs. If this happens the thermal cut outs switch off the appliance. The appliance will not operate until it has cooled down.

NOTE: DO NOT COVER the air inlet or outlet grilles, at any time.

9.2 To reset the self hold cut-out

- The cut-out is reset by switching OFF mains power to the appliance.
- Allow the appliance to cool for 20 minutes.

- Switch ON the appliance. If the cut-out trips again, a qualified electrician should be consulted.

9.3 Fault conditions

If the heater will not operate, disconnect it from the mains and arrange for a certified electrician to attend to investigate the reason.



WARNING:

THIS HEATER SHOULD NOT BE INSTALLED WHERE THERE IS A CORROSIVE ATMOSPHERE.



Nortek Global HVAC (UK) Ltd
Fens Pool Avenue
Brierley Hill
West Midlands DY5 1QA
United Kingdom

Tel: 01384 489250
Fax: 01384 489707

ambiradsales@nortek.com
www.ambirad.co.uk

AMBIRAD AIRBLOC NORDAIRNICHE BENSON

Registered in England No. 1390934. Registered office: 10 Norwich Street, London, EC4A 1BD

Nortek Global HVAC is a registered trademark of Nortek Global HVAC Limited. Because of continuous product innovation, Nortek Global HVAC reserves the right to change product specification without due notice.