

## INSTALLATION / OPERATION / MAINTENANCE

Applies to:

**Model ARC 120V 60Hz  
Gas-Fired, Continuous Radiant  
Tube Heating System**



# ARC Series

CONTINUOUS RADIANT TUBE HEATING SYSTEMS

**⚠** WARNING: Improper installation, adjustment, alteration, service or maintenance can cause property damage, injury or death. Read the installation, operating and maintenance instructions thoroughly before installing or servicing this equipment.



# AMBIRAD

HEATING AND VENTILATION SOLUTIONS

Part # 700150

## 1 Installation Requirements

- 1.1 Health & Safety
- 1.2 Warnings
- 1.3 Burner Model Definitions
- 1.4 Heater Suspension
- 1.5 Wall Mounting
- 1.6 Clearance to Combustibles
- 1.7 Gas Connection & Supply Details
- 1.8 Electrical Connections
  - 1.8.1 Fan Terminal Connections
  - 1.8.2 Pressure Switch Connections
  - 1.8.3 Optional Modulation Damper
  - 1.8.4 Typical Wiring Schematic
  - 1.8.5 Typical External
  - 1.8.6 Wiring Details
- 1.9 Ventilation Requirements
- 1.10 Ducted Air Inlet Considerations
- 1.11 Vacuum Fan Details
- 1.12 Technical Data

## 2 Assembly Instructions

- 2.1 Tools Required
- 2.2 Assembly Notes
  - 2.2.1 Radiant Tubes
  - 2.2.2 Couplers
  - 2.2.3 Reflectors
    - 2.2.3.1 Standard Reflectors
    - 2.2.3.2 Perimeter Reflectors
    - 2.2.3.3 Corner Reflectors
    - 2.2.3.4 Tee Reflectors
  - 2.2.4 Brackets
    - 2.2.4.1 Suspension Brackets
    - 2.2.4.2 Reflector Support Brackets
      - 2.2.4.2.1 Reflector Support Attachment
  - 2.2.5 Burner
    - 2.2.5.1 LR Burner
    - 2.2.5.2 Burner Head
  - 2.2.6 End Vent Module
  - 2.2.7 Vacuum Fan
- 2.3 Installation of End Vent/In-line Section
- 2.4 Installation of Radiant Tube to Tail Pipe
- 2.5 Installation of Main Reflectors
- 2.6 Installation of Corner Reflector
- 2.7 Installation of Tee Reflector
- 2.8 Final Fixture and Adjustments
- 2.9 Installation of Fan Exhaust System
  - 2.9.1 Vertical Discharge
  - 2.9.2 Horizontal Discharge
  - 2.9.3 Fan Mounting
  - 2.9.4 Condensate Trap
  - 2.9.5 Optional Modulation Damper
- 2.10 Full Breakdown of Typical System
- 2.11 Installation of End Vent and In-line Burners
- 2.12 Installation of End Vent Module (EVM)
- 2.13 Installation of Ducted Air Adaptors
  - 2.13.1 Burner Assembly Adaptor
  - 2.13.2 End Vent Module Adaptor

- 2.14 Installation of Ball Guard System
  - 2.14.1 Installation
  - 2.14.2 Blanking Shield
- 2.15 Installation of Slimline Decorative Grille System
  - 2.15.1 Standard Modular Assembly
  - 2.15.2 Shortened Assemblies
- 2.16 Installation of Blanking Shields
- 2.17 Installation of Undershield Deflectors
- 2.18 End Vent Silencer

## 3 Commissioning Instructions

- 3.1 Tools Required
- 3.2 General
- 3.3 Commissioning Procedure
  - 3.3.1 Start Up Checks
    - 3.3.1.8 Burner Timer Dip-switch Settings
- 3.4 Set Up
- 3.5 Final Commissioning
- 3.6 Optional Damper Suction Procedure
  - 3.6.1 Optional Damper Technical Details
- 3.7 Typical Unequal Balanced System Layout

## 4 Servicing Instructions

- 4.1 Tools Required
- 4.2 Burner Exploded Views
- 4.3 Vacuum Fan
- 4.4 Radiant Tubes
- 4.5 Tube Couplers
- 4.6 Reflectors
- 4.7 Condensate Trap
- 4.8 Burner Electrodes
- 4.9 Burner Head
- 4.10 Filters
- 4.11 Combustion Chamber Viewing Window

## 5 Spare Parts

- 5.1 Required Spares List
- 5.2 Injector/Air Shutter Selection

## 6 Fault Finding Guide

## 7 Replacing Parts

- 7.1 Removal of Burner Assembly
- 7.2 Gas Valve Replacement
- 7.3 Filter Replacement
- 7.4 Controller Replacement
- 7.5 Sequence Timer Replacement
- 7.6 Electrode Assembly Replacement
- 7.7 Injector Replacement
- 7.8 Combustion Chamber Window Replacement

## 8 User and Operating Instructions

- 8.1 To Start Heater
- 8.2 To Switch Off Heater
- 8.3 Routine Maintenance Between Service Intervals
- 8.4 Frequency of Servicing

# Introduction

Welcome to the range of AmbiRad ARC Continuous radiant tube heating system. Local regulations may vary and it is the installer's responsibility to ensure that such regulations are satisfied.

All installation, assembly, commissioning and service procedures must be carried out by suitable qualified competent persons and conform with local building codes, or in the absence of local codes, with the National Fuel Gas Code ANSI Z223.1/NFPA 54.

When assembling, installing, commissioning and servicing is undertaken on radiant tube heaters specified in these instructions, due care and attention is required to ensure that working at height regulations are adhered to at the mounting heights specified.

PLEASE READ this document prior to installation to familiarize yourself with the components and tools you require at the various stages of assembly.

All Dimensions shown are in inches unless otherwise stated.

**The manufacturer reserves the right to alter specifications without prior notice.**

The Ambi-Rad ARC Continuous radiant tube heating system comprises of a continuous system with a number of burners located in series in a radiant branch, and a number of radiant

branches manifolded together, linked by a tail pipe to a vacuum fan discharging the spent products of combustion to atmosphere. A system may comprise of just one burner and one vacuum fan, to multiple burners in multiple radiant branches with one or more vacuum fans.


To enable exact matching of operational needs within an area, distances between burners and ratings of the burners can vary. The unique feature of 'ARC' series is a radiant system which provides uniform heat coverage of the floor area, eliminating hot/cold spots.

The tube into which the burners are mounted and over which the reflectors are fitted and emits the maximum heat is called the radiant tube. The radiant heat emitted from the hot tube is directed downwards by reflectors. The remaining interconnecting tube is called the tail pipe and radiates with less intensity.

**The operating temperatures of the tubes generally range from 400°F – 900°F max.**

The action of the vacuum fan is three fold; to create a high negative pressure within the radiant tube and tail pipe so as to discharge the spent products of combustion from the system to a point outside the building being heated; to control the flow of gas and air through each burner in stoichiometric proportions; to draw carrier air into the tube system at the start of each radiant branch, in order to distribute the heat from the flame along the tube.

## 1. Installation Requirements.


 Isolate any electrical supply to the heater and controller before proceeding.

### 1.1 Health and Safety


- A. Heater is intended for heating non-residential indoor spaces and should only be installed where flammable gases or vapors are not generally present.
- B. Heaters may be suspended either horizontal or at an angle, or may be wall mounted. See section 1.5 for clearance dimensions.
- C. The installation must conform with local building codes or, in the absence of local codes, with the National Fuel Gas Code, ANSI Z223.1/NFPA 54.
- D. The unit shall be electrically grounded in

- E. accordance with National Electric Code ANSI/NFPA 70.
- The heater may be installed in aircraft hangars installed in accordance with the Standard for Aircraft Hangars, ANSI/NFPA 409 and in automotive garages when installed in accordance with the Standard for Parking Structures, ANSI/NFPA 88A, or the Standard for Repair Garages, ANSI/NFPA 88B, and are so marked.
- Ensure that minimum clearances will be maintained to vehicles parked below the heater.
- For your own safety we recommend the use of safety boots and leather faced gloves when handling sharp or heavy items. The use of protective eye wear is also recommended

## 1.2 Warnings


 **Improper installation, adjustment, alteration, service or maintenance can cause property damage, injury or death. Read the instructions thoroughly before installing or servicing this equipment.**

### FIRE OR EXPLOSION HAZARD

 Clearances to combustibles must be maintained in all situations. Failure to maintain clearances to combustibles could result in a serious fire hazard, injury or death. Minimum clearances must be maintained from vehicles, aircraft and all items below the system.

In locations used for the storage of combustible materials signs shall be posted to specify the maximum permissible stacking height to maintain required clearances from the heater to the combustibles. In addition the manufacturer recommends posting these signs adjacent to the heater thermostats for enhanced visibility

### MECHANICAL/SUSPENSION HAZARD


 During each operating cycle, this equipment will expand and contract. The suspension method, gas connection and the total installation must safely allow for this movement. Failure to comply with the above, could result in serious fire or explosion hazard.

Beware of sharp edges on reflectors, tubes and metal components. Always wear protective gloves as sharp edges could cause injury. Use due care in lifting any component of the system to high level - use adequately sized lifting tackle for the weight of the component. Do not lift components when personnel could be exposed to danger if the lifting tackle were to fail.

All hooks should be closeable safety link type. If 'S' hooks are utilized, they must be closed to prevent any possibility of equipment becoming disengaged.


Do not lean ladders or other objects against the system. Failure to comply with any of the above could result in serious injury

### GAS EXPLOSION HAZARD

 To avoid the possibility of gas leaks, which can cause damage and death, the

gas connections should be made as indicated. Allow for system expansion, use relevant jointing compounds on gas connections and do not exceed maximum gas pressure at burners.


### ELECTRIC HAZARDS

 The heater/vacuum pump must be grounded in accordance with the relevant codes in the USA and Canada.

All electrical connections should be made in accordance with these codes.


A competent electrician familiar with relevant codes and practice should install the system.

### MECHANICAL HAZARD-VACUUM PUMP

 High-speed rotation of vacuum pump can cause serious injury. Care must be taken when working near pumps, to avoid loose clothing becoming entangled.


Avoid touching rotating parts with hands. When inspecting vacuum pumps ensure that electrical supply is switched off.

### TESTING AND BALANCING

 On completion of installation start-up should be undertaken by a competent gas engineer following the commissioning instructions provided by the manufacturer.

Special attention should be given to testing and confirming the correct operation of the ignition and burner fail safe system and the correct setting of the gas pressure regulator.


### ELECTRICAL/MECHANICAL HAZARDS

 When checking for faults do not put hands near rotating parts of vacuum pumps.

Do not touch live electrical components or wiring in the burner housing.

When working inside the burner-housing switch off/disconnect the electrical supply.

### HAZARDOUS AREAS


 Do not install the system in hazardous areas containing halogenated hydrocarbons, corrosive chemicals or volatile atmospheres. Serious injury or death can result.

### 1.3 Burner Model Definitions





**ARCxxLR** = Continuous radiant tube heater.

xx denotes kW rating. Models available; 12, 18, 24, 32, 38 and 46

### 1.4 Heater Suspension

 The system is assembled at high level suspended by chains from first fixings to the roof structure.  
(First fixings by others)

#### 1.4.1 First considerations

-  Clearances from combustibles must be maintained. (See figure 1d)
-  For ease of servicing there should be a minimum clearance distance of 1'6" between the burners of the heating system and the building wall. This measurement can be reduced for perimeter type systems. (See figure 1c).
-  For ease of servicing and burner removal minimum clearances should be maintained. (See figure 1e and 1f). In exceptional circumstances the burner lid may be slid horizontally for removal thus reducing the vertical distance.
-  Ensure that the suspension is sufficiently flexible to allow for thermal expansion.

#### 1.4.2 Suspending the heater - General

**1.4.2.1** The first support is always positioned at the support lug suspension point on the end vent burner combustion chamber.

**1.4.2.2** Subsequent supports are placed approximately 9ft apart, including one at each combustion chamber location. This gives a maximum load per support of 53lbs.

**1.4.2.3** A support must always be located at a maximum distance of 6' 6" from a tee or elbow fitting.

**1.4.2.4** Except for the combustion chamber support lug suspension points, suspension support brackets are installed to support the tube section which is then covered with reflectors.

**1.4.2.5** Tail pipe hangers are installed for the tube section which will be without reflectors.

If there are any doubts as to the strength or suitability of roof steelwork to which heaters are to be suspended, please refer to a Consultant, Architect or owner of the building.

Attachment to the heater support lugs should be made by a 'speed link', D shackle, carabiner clip or in the case of drop rods, a closed formed hook. The hanging attachments to overhead steelwork etc. must be purpose made to good sound engineering practice or of a proprietary type fixing. They must be adequately fixed and designed to carry the whole weight of the heater. In the event of suitable roof steelwork being unavailable, additional steelwork should be fitted to enable vertical hangers to be used for suspending the heaters.

These methods are illustrated in Figure 1a and 1b. If there are any doubts as to the strength or suitability of roof steelwork to which heaters are to be suspended, please refer to a Consultant, Architect, structural engineer, or owner of the building.

The suggested mounting heights for AmbiRad heaters are given in table 1 below.

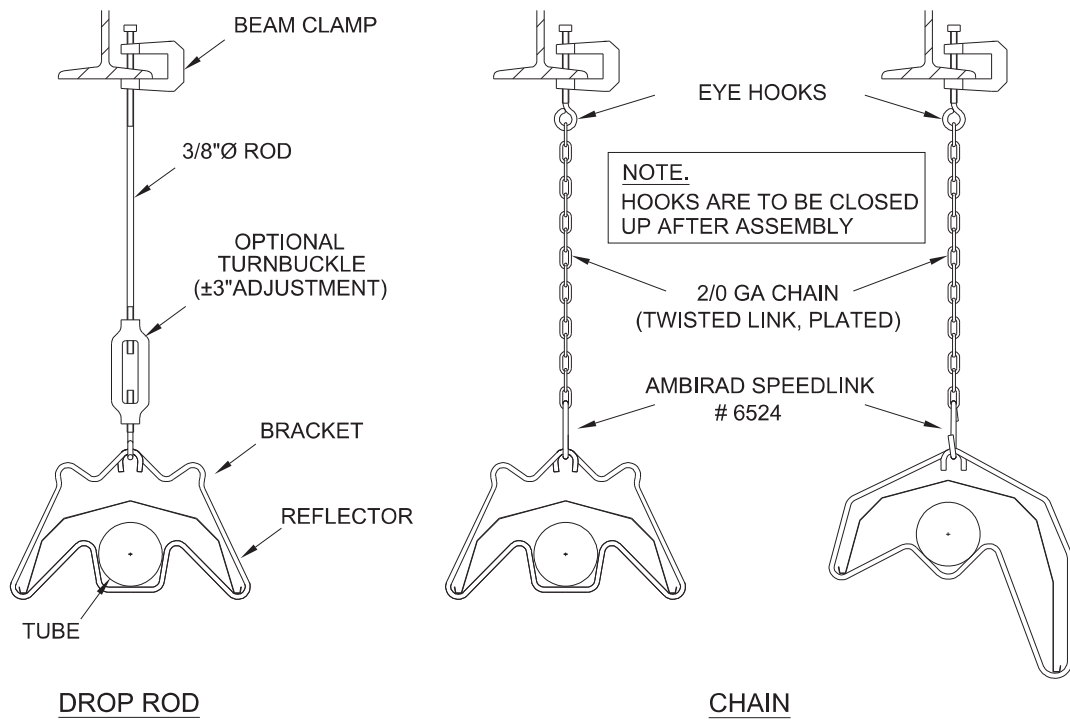
Model	Minimum Mounting Heights (ft/in)
<b>ARC12LR</b>	10' 0"
<b>ARC18LR</b>	12' 0"
<b>ARC24LR</b>	13' 0"
<b>ARC32LR</b>	15' 0"
<b>ARC38LR</b>	18' 0"
<b>ARC46LR</b>	20' 0"

### 1.5 Wall Mounting

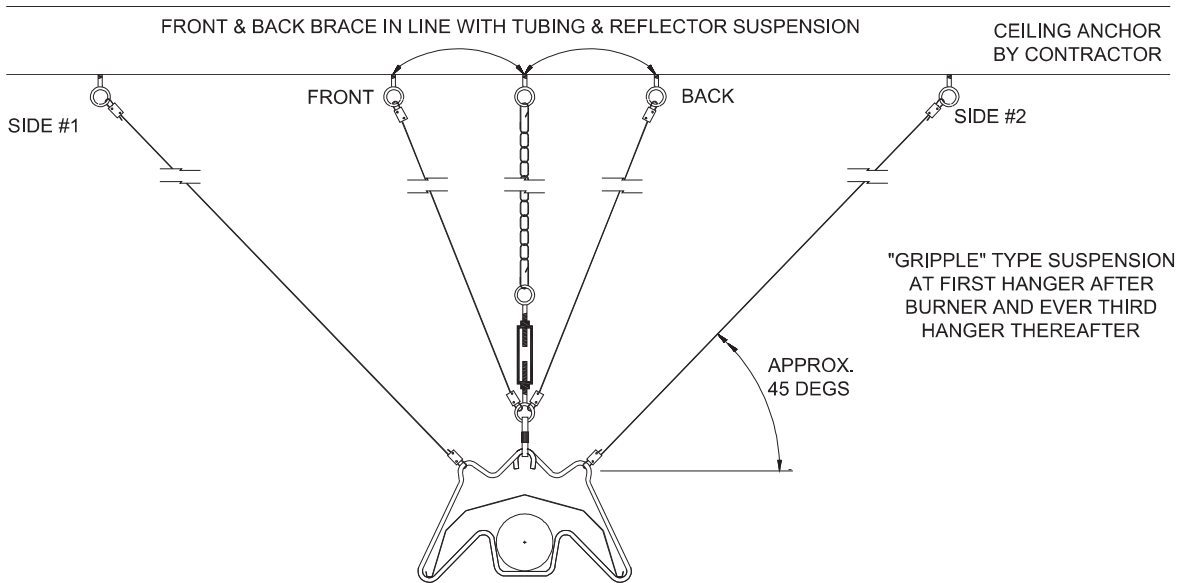
These radiant tube heaters can be wall mounted using the appropriate bracket.

When using the wall mounting brackets the heater must be inclined at an angle between 35° and 55°, when side wall (perimeter) reflectors are not used.

**Figure 1a. Recommended Methods of Heater Suspension.**

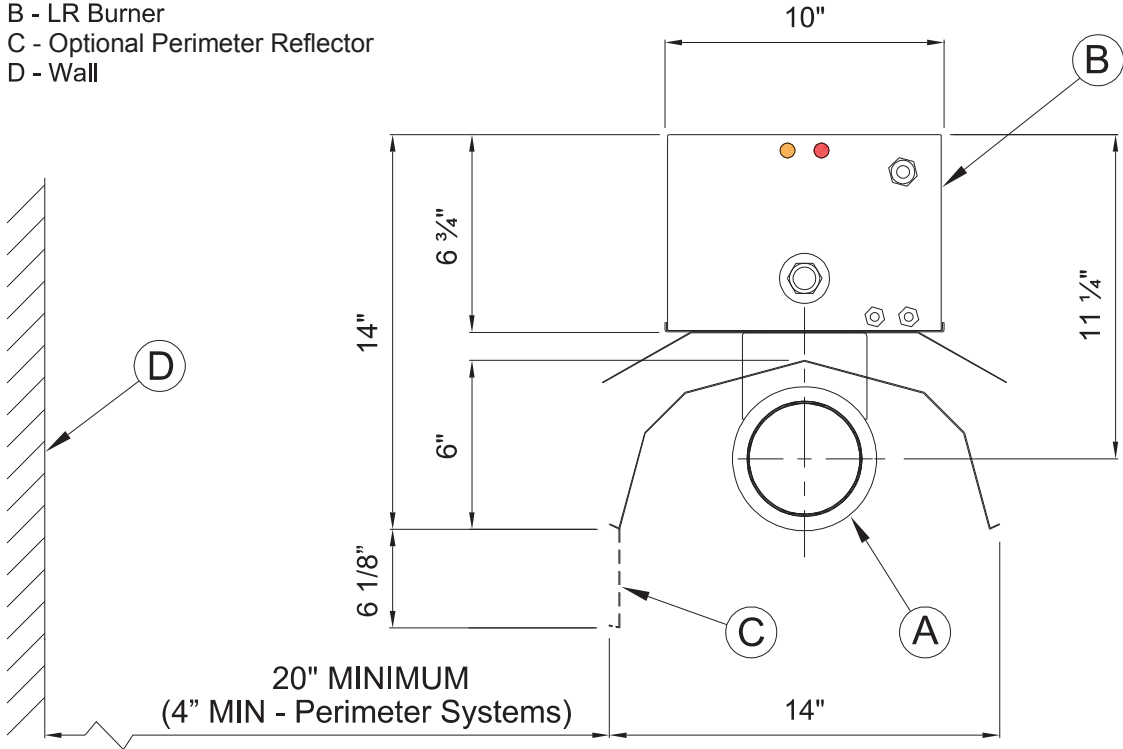


**Figure 1b. Bracings to eliminate sway - optional**



**Figure 1.c Overall Dimensions**

- A - Burner Tube
- B - LR Burner
- C - Optional Perimeter Reflector
- D - Wall



**1.6 Clearance to Combustibles.**

**WARNING:** <sup>ⓘ</sup> The minimum clearances to combustible materials are given in table 2. These minimum distances **MUST** be adhered to at all times.

**IMPORTANT:** The stated clearance to combustibles represents a surface temperature of 90°F (32°C) above room temperature.

Building material with a low heat tolerance may be subject to degradation at lower temperatures.

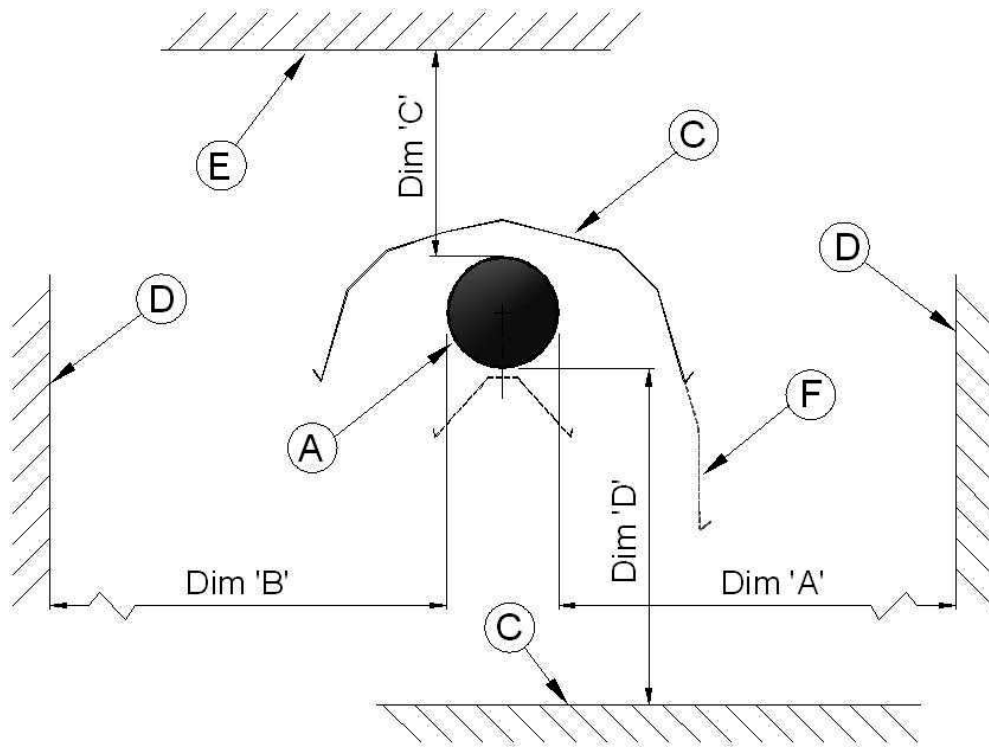
It is the installer's responsibility to assure that adjacent material are not subject to degradation.

**WARNING:**

**Minimum clearance from the heater must be maintained from vehicles parked below heater. In all situations, clearances to combustibles must be maintained.**

**Signs should be posted in storage areas to specify maximum stacking height to maintain required clearance to combustibles. Refer to mounting clearance tables.**

Figure 1d Diagram illustrating the clearance to combustibles



A Radiant tube; B Standard reflector; C Combustible material underneath; D Combustible material on side; E Combustible material above; F Perimeter reflector;

Table 2 clearance to combustibles

Burner Model	ARC12LR		ARC18LR		ARC24LR		
	End vent	In-line	End vent	In-line	End vent	In-line	
<b>Below tube</b>							
Dim D Without undershield	in	44	50	44	50	44	50
Dim D With undershield	in	30	34	30	34	30	34
Dim C Above Tube	in	4					
<b>Horizontally</b>							
Dim B Standard reflector	in	20	20	20	20	28	28
Dim A Perimeter reflector	in	12	12	12	12	12	12
Burner Model	ARC32LR		ARC38LR		ARC46LR		
	End vent	In-line	End vent	In-line	End vent		
<b>Below tube</b>							
Dim D Without undershield	in	56	67	63	83	67	83
Dim D With undershield	in	30	34	31	41	34	41
Dim C Above Tube	in	4					
<b>Horizontally</b>							
Dim B Standard reflector	in	28	34	28	39	28	39
Dim A Perimeter reflector	in	12	20	12	24	12	24



Figure 1.e Clearance for servicing - distances to walls and obstacles above.

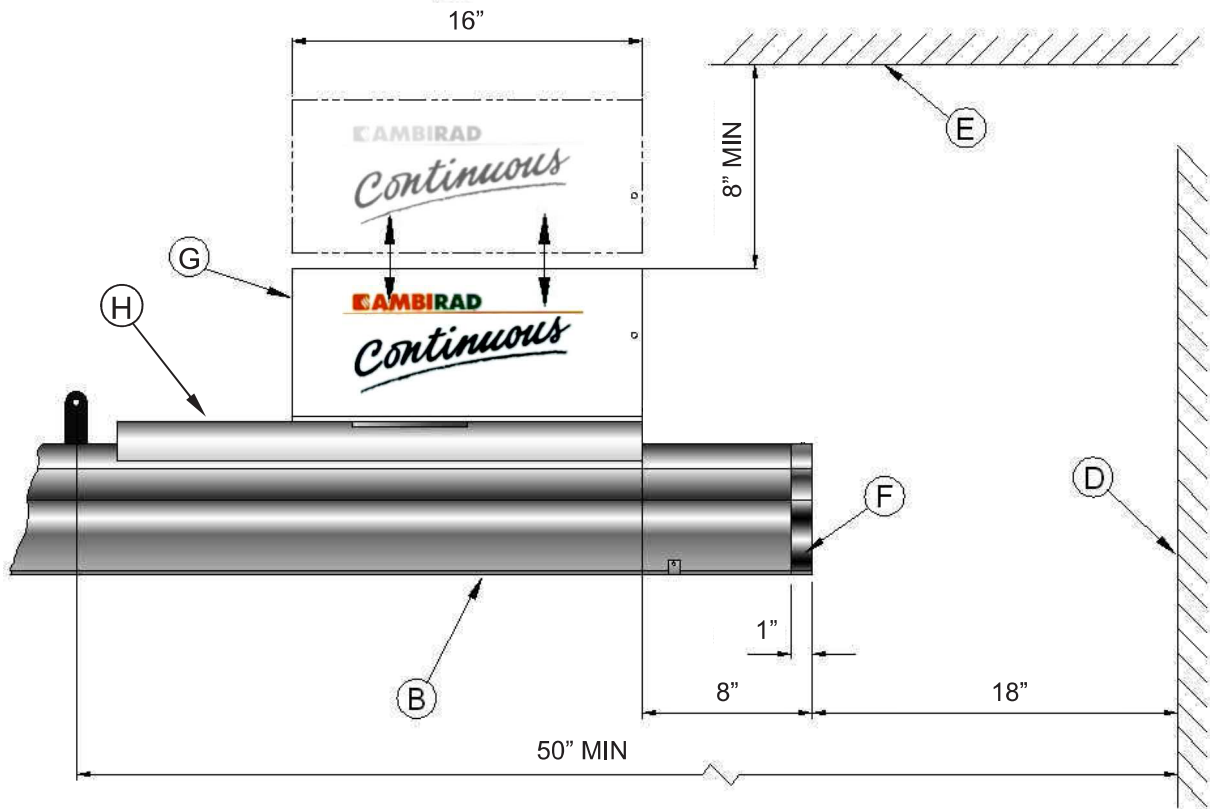
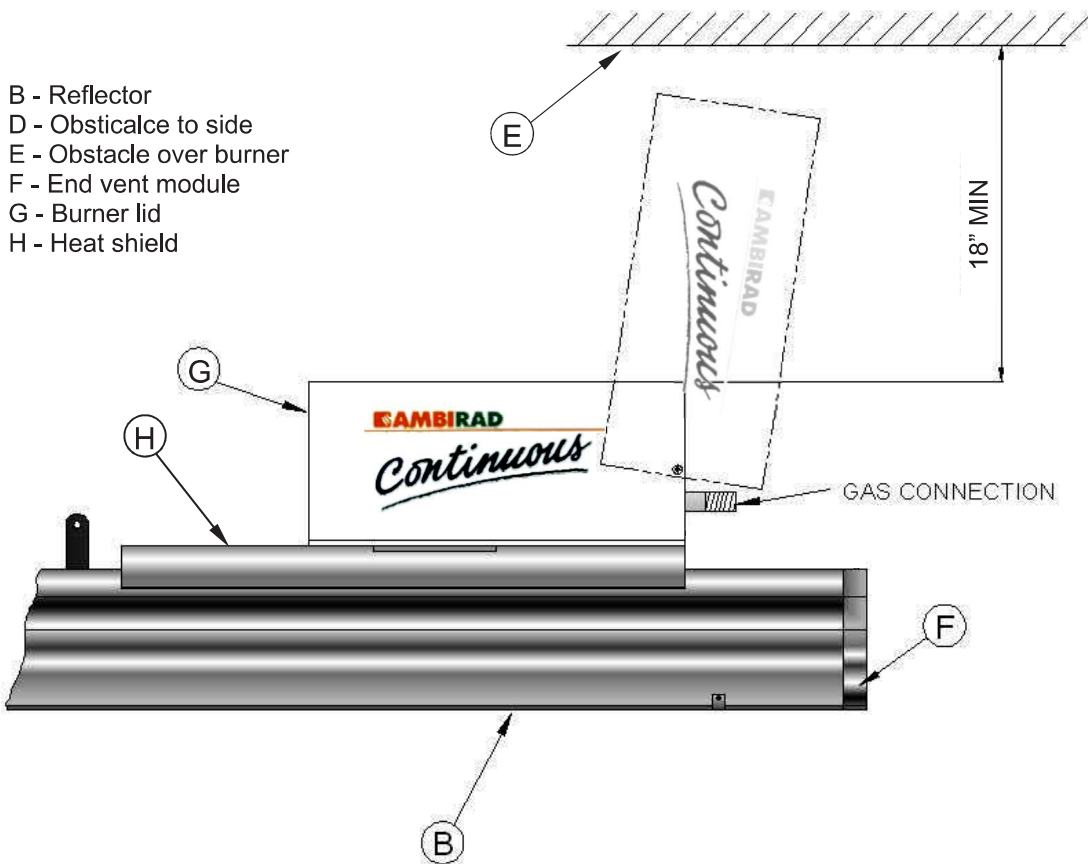


Figure 1.f Clearance for servicing - distances to obstacles above.



- B - Reflector
- D - Obstacle to side
- E - Obstacle over burner
- F - End vent module
- G - Burner lid
- H - Heat shield

## 1.7 Gas Connection and Supply

**WARNING:** Before installation, check that the local distribution conditions, nature of gas and pressure, and adjustment of the appliance are compatible.

The gas connection on the heater is ½" N.P.T external thread.

Injector sizes and manifold pressure for the burners are shown in the table 3. The gas supply piping and connections must be installed so that the minimum pressure stated is achieved.

A gas shut off valve and union should be fitted in the gas supply line close to the heater and a ⅛" N.P.T plugged tapping, accessible for test gauge connection, provided immediately upstream of the appliance gas inlet.

It is essential to provide some flexibility in the final gas connection preferably by use of an approved flexible gas connector or stainless steel expansion loop.

Take care when making a gas connection to the heater not to apply excessive turning force to the internal controls.

Depending on the specific installation, the flexible gas hose may be routed to the gas cock at any of the following angles in relation to the burner:

Care must be taken to observe the minimum pipe bend diameter (minimum 10", maximum 14") & pipe expansion distance (minimum 1 ⅛", maximum 3 ¾").

The correct installation as shown will allow for approx 4" of movement due to expansion.

Figure 2. Correct orientation of Ball Valve

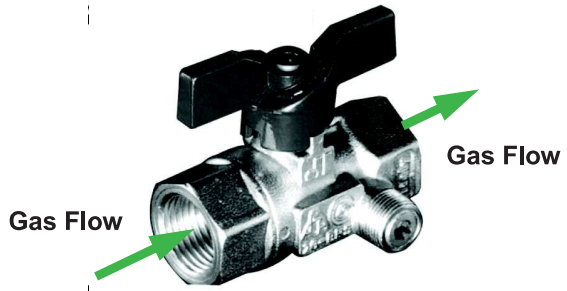
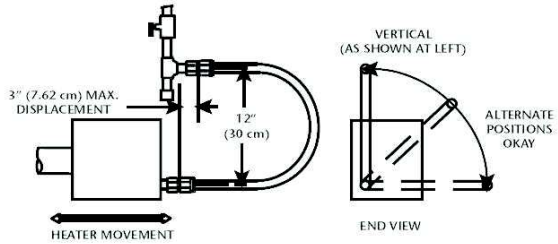
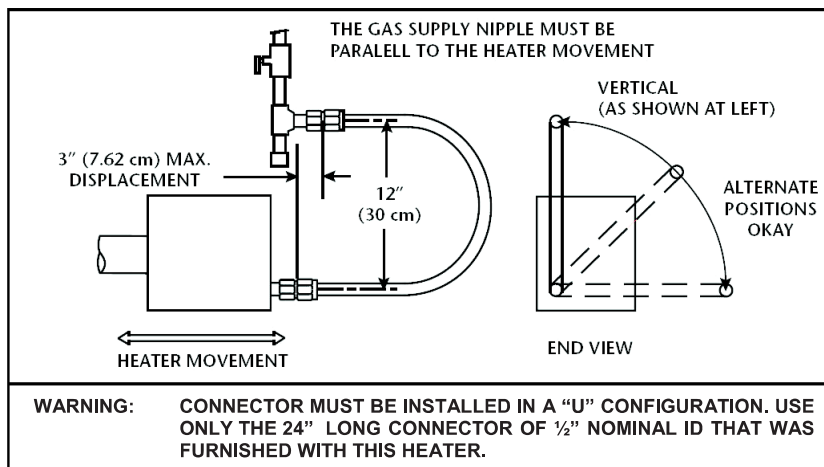
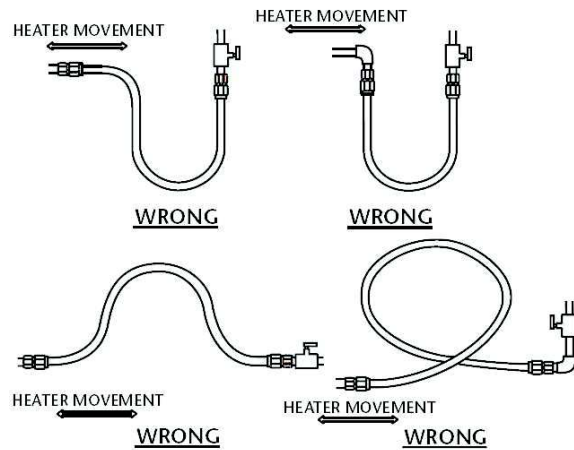


Figure 3. Correct Installation of Flexible Gas Connection

### CORRECT POSITIONS



### INCORRECT POSITIONS



**! WARNING: FIRE OR EXPLOSION HAZARD - Expansion of the radiant pipe occurs with each firing cycle causing the burner to move with respect to the gas line. This can result in a gas leak producing an unsafe condition. It is therefore essential to provide some flexibility in the final gas line connection by use of an approved armoured flexible connector or stainless steel expansion loop as shown in the drawings.**

**Table 3 Gas Supply Pressures**

Gas Type	Natural Gas	Propane
Nominal Supply Pressure (in w.c.)	7	11
Max Supply Pressure (in w.c.)	14	14
Min Supply Pressure (in w.c.)	4.8	4.8
Gas Supply Connection	½" N.P.T internal thread	

**1.8 Electrical Connections**

**! WARNING: Before making electrical connections, switch OFF the main electrical disconnect. There may be more than one disconnect switch. Lock out and tag switch with a suitable warning label. Electrical shock can cause personal injury or death.**



This appliance must be electrically grounded

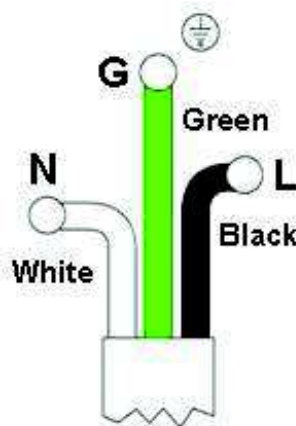
Supply 120V 60Hz single phase.  
 Standard heater 0.16HP.  
 Current rating 1.2 amp max (inductive).  
 Fuse: external 3 amp.

Important: All electrical work should be done by a qualified electrician in strict accordance with the National Electrical Code ANSI/NFPA 70.

The electrical supply to the heater is by three wires: live, neutral and ground connections.

Install in accordance with all state & local codes.

It is recommended that the electrical circuit controlling the



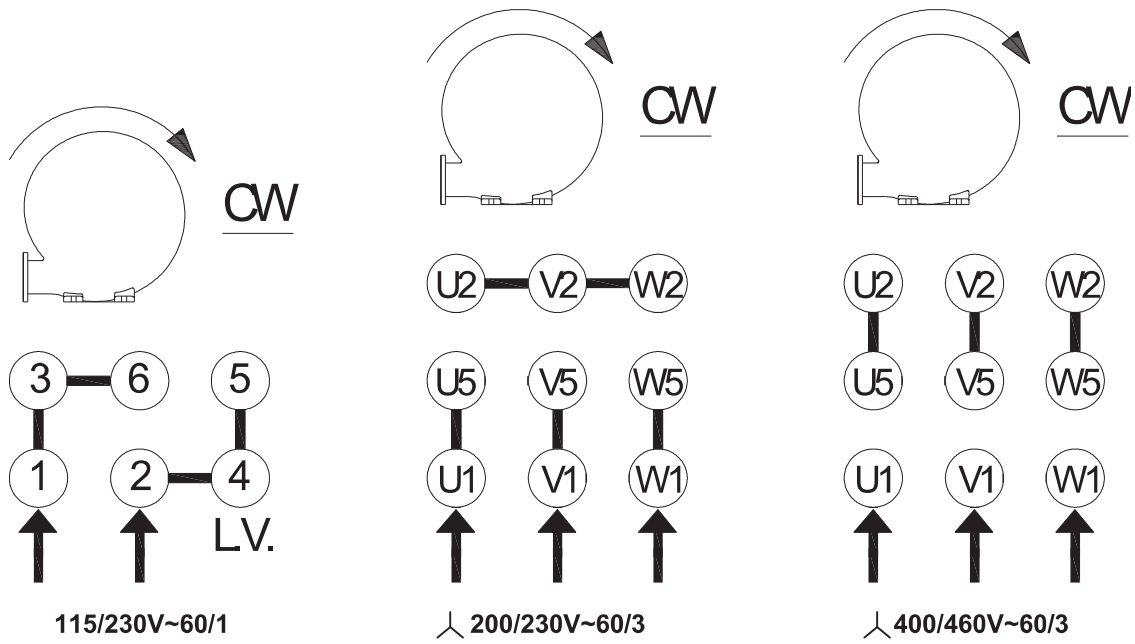
heater or group of heaters are controlled via a SmartCom Control Panel.

SmartCom<sup>3</sup> provides cost effective energy for small single heater installations through to large multi-zone applications requiring centralised control.

For further information, please contact your local distributor.

Where alternative manufactures' controls are used, please refer to their instructions for their siting and installation details.

### 1.8.1 Fan Terminal Connections



### 1.8.2 Pressure Switch Connections

The pressure switch is attached to the damper assembly

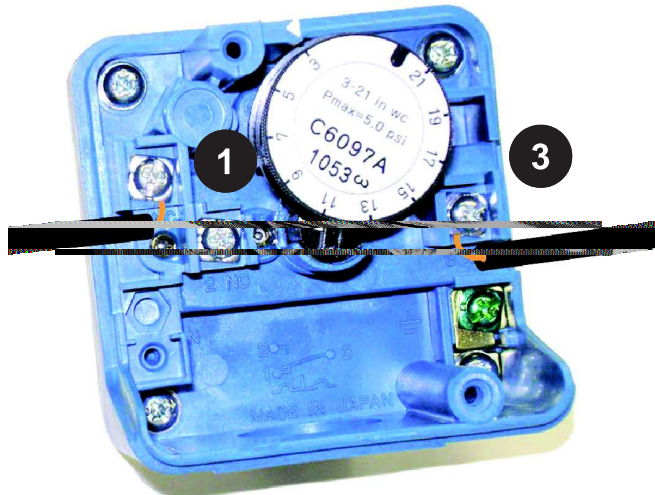
Release the plastic cap via two screws.

FOR SMARTCOM CONTROLLERS ONLY:

connect the incoming cable to terminal 1 - (normally closed contact) and terminal 3 - (common contact)

Replace the plastic cap via two screws.

Note: remove label covering the 1/4" hole

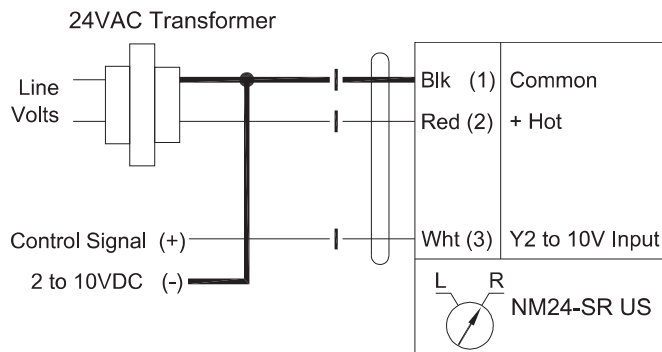


### 1.8.3 Optional Modulation Damper

The modulation damper (optional - where fitted) is attached to the damper assembly

The three cables from the damper modulator unit are wired:

Black: common 0V,  
Red +Hot 24V and  
White: 0-10Vdc signal.



### 1.8.4 Damper Connections

The fan damper is wired via a plug and socket arrangement. The socket is connected to the assembly via a bracket.

Release the loose plug and remove the cap via two screws.

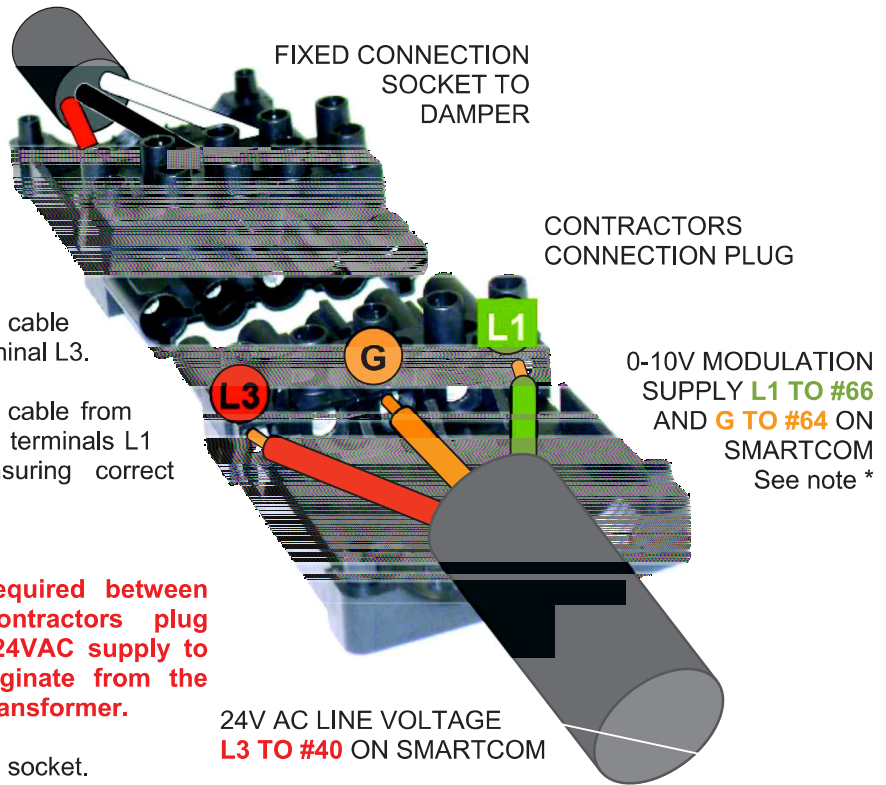
Connect the incoming 24V cable from SmartCom #40 onto terminal L3.

Connect the incoming 0-10V cable from SmartCom #66 and #64 onto terminals L1 and GND respectively, ensuring correct orientation.

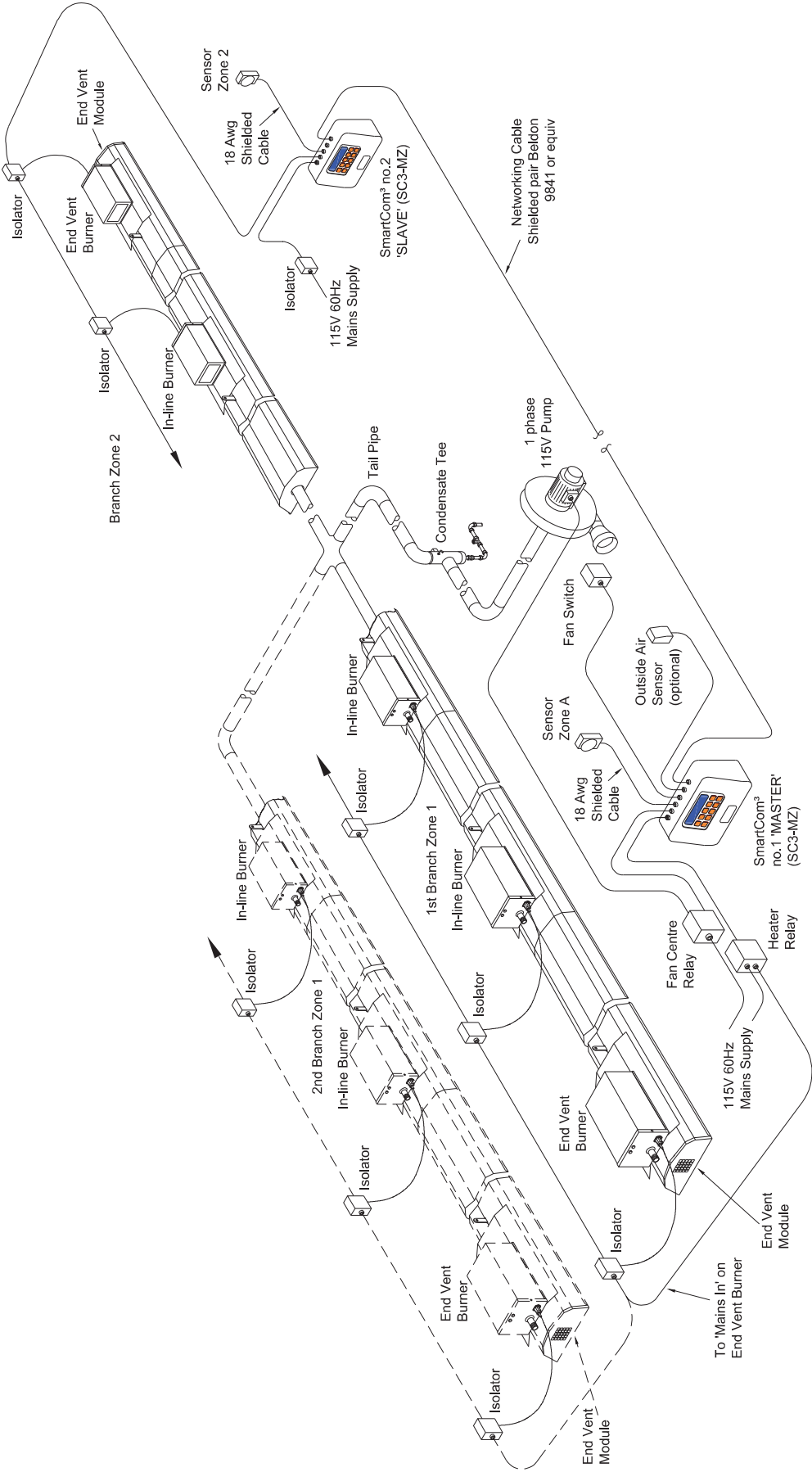
**\* IMPORTANT:**

**An additional cable is required between SmartCom #2/N and contractors plug terminal GND only if the 24VAC supply to the panel DOES NOT originate from the secondary of an isolating transformer.**

Replace the cap and plug into socket.



### 1.8.5 ARC LR system - Typical External Diagram



### 1.8.6 Wiring Details

Figure 4.a. LR internal wiring diagram

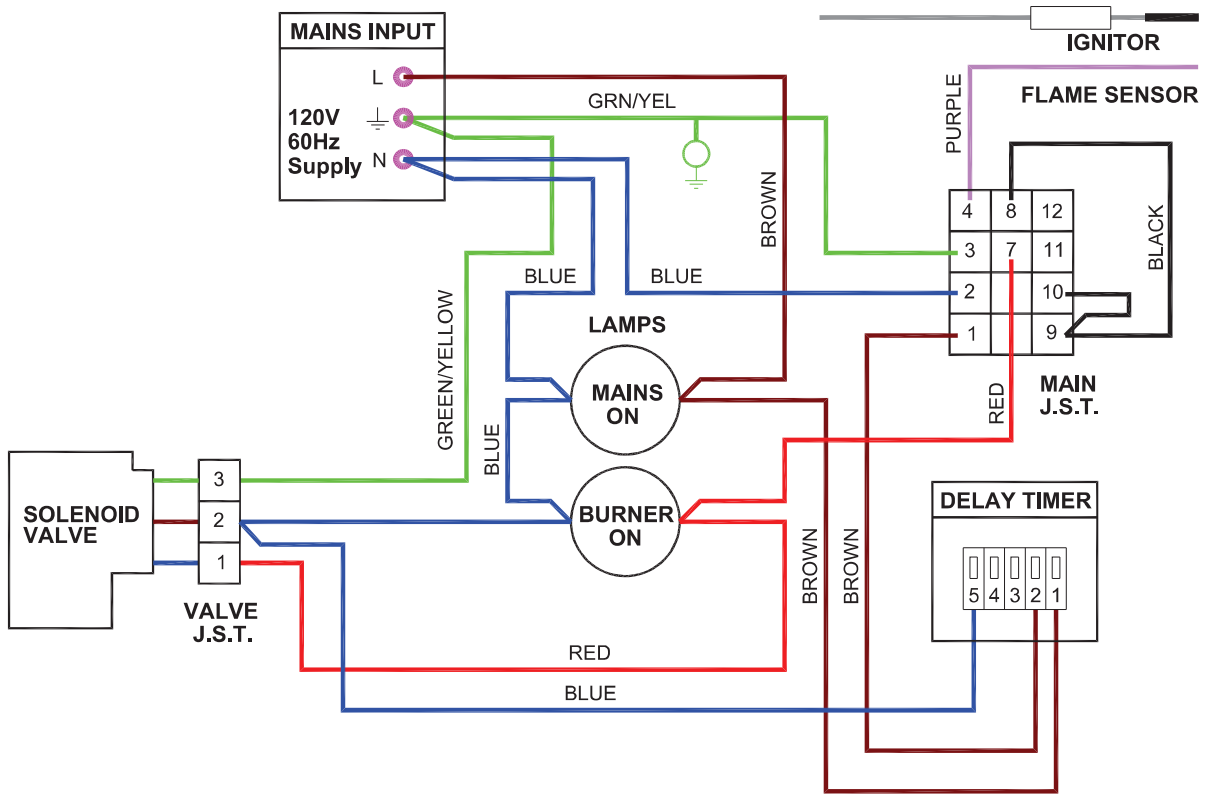


Figure 4.b. LR internal wiring diagram - c/w N/O or N/C volt free Lockout contacts

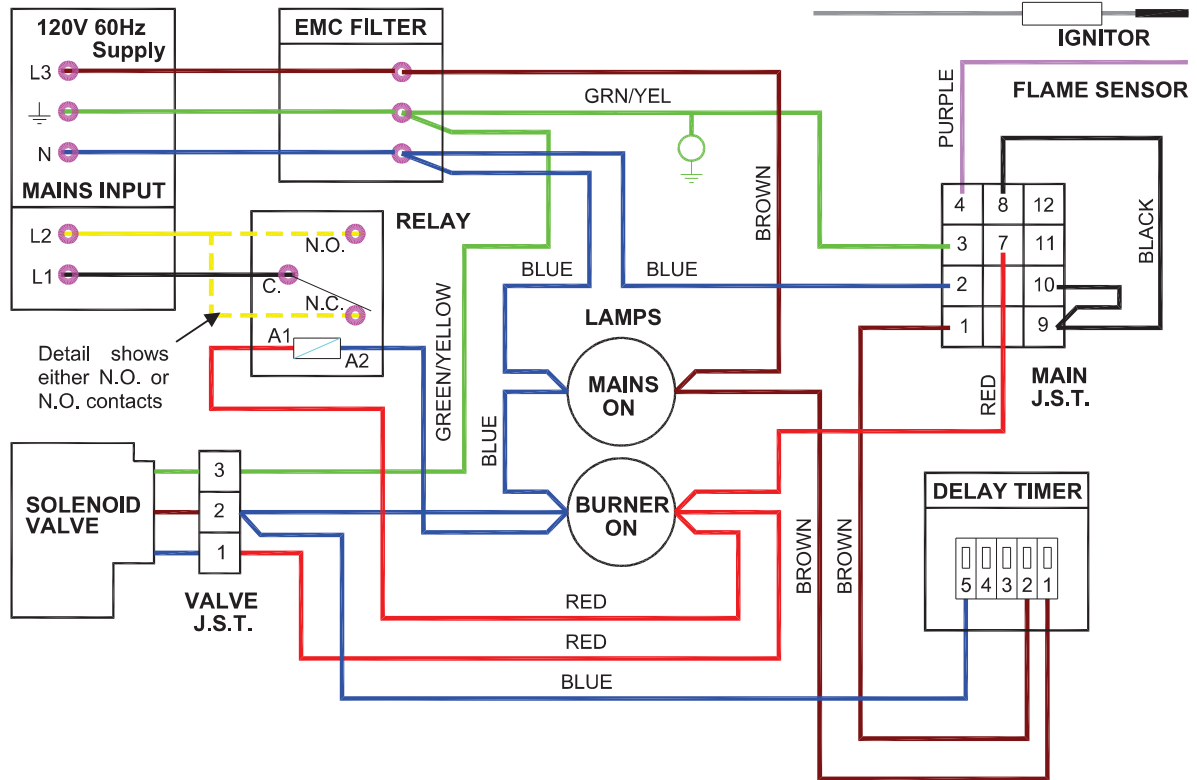
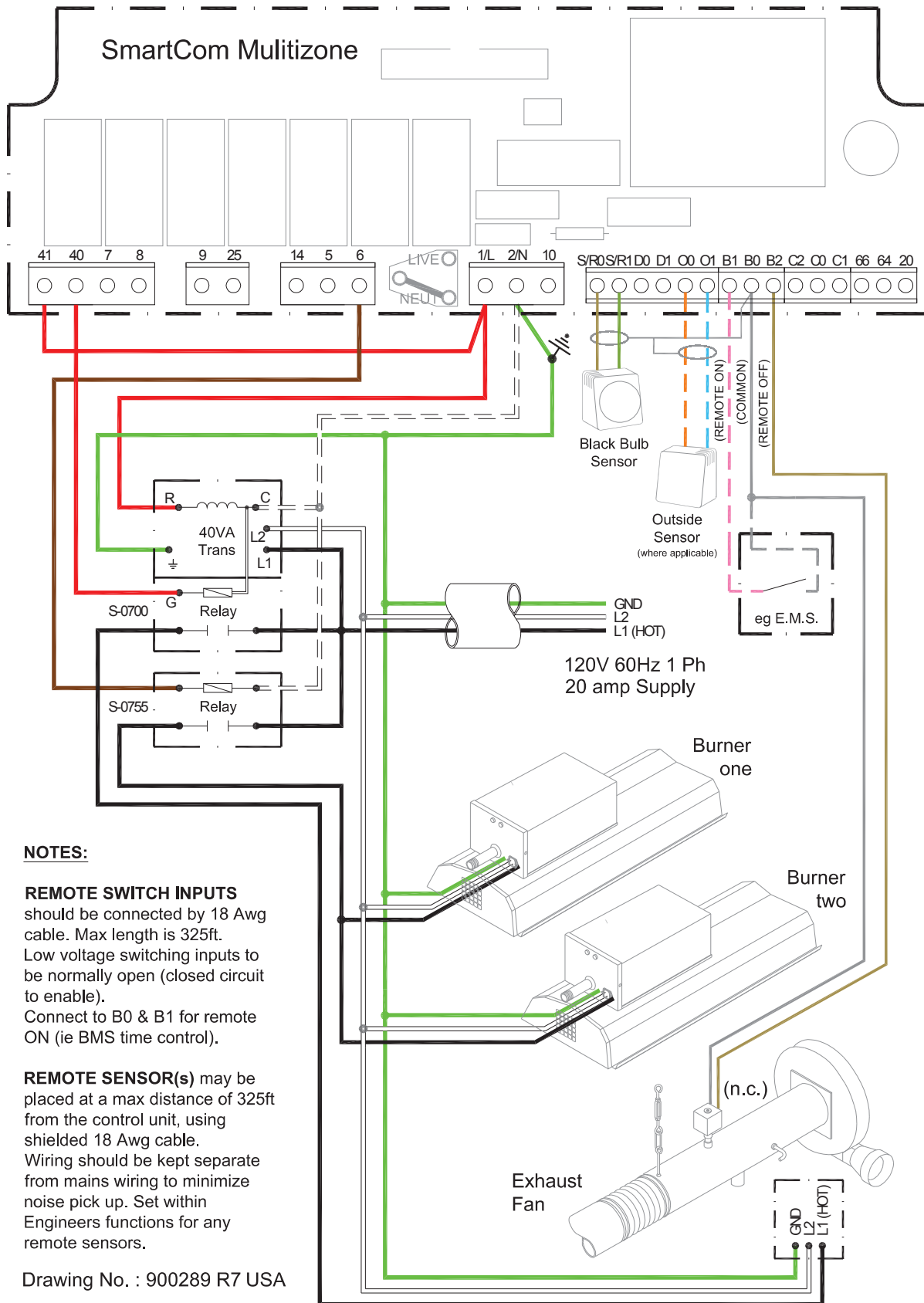


Figure 4.c. ARC Single Zone schematic interconnecting wiring.



**NOTES:**

**REMOTE SWITCH INPUTS** should be connected by 18 Awg cable. Max length is 325ft. Low voltage switching inputs to be normally open (closed circuit to enable). Connect to B0 & B1 for remote ON (ie BMS time control).

**REMOTE SENSOR(s)** may be placed at a max distance of 325ft from the control unit, using shielded 18 Awg cable. Wiring should be kept separate from mains wiring to minimize noise pick up. Set within Engineers functions for any remote sensors.

Drawing No. : 900289 R7 USA



**NOTES:**

**NETWORK.** Master-slave (Network) communication is by shielded twisted pair cable, RS485 compatible such as Belden 9841. Maximum overall system length of 1650ft Connect screen to C0. NOTE: Diagram shows a master and ONE slave configuration\*\*. Wire further slaves in parallel.

**REMOTE SWITCH INPUTS** should be connected by 18 Awg cable. Max length is 325ft. Low voltage switching inputs to be normally open (closed circuit to enable). Connect to B0 & B1 for remote ON (ie BMS time control).

**REMOTE SENSOR(s)** may be placed at a max distance of 325ft from the control unit, using shielded 18 Awg cable. Wiring should be kept separate from mains wiring to minimize noise pick up. Set within Engineers functions for all remote sensors.

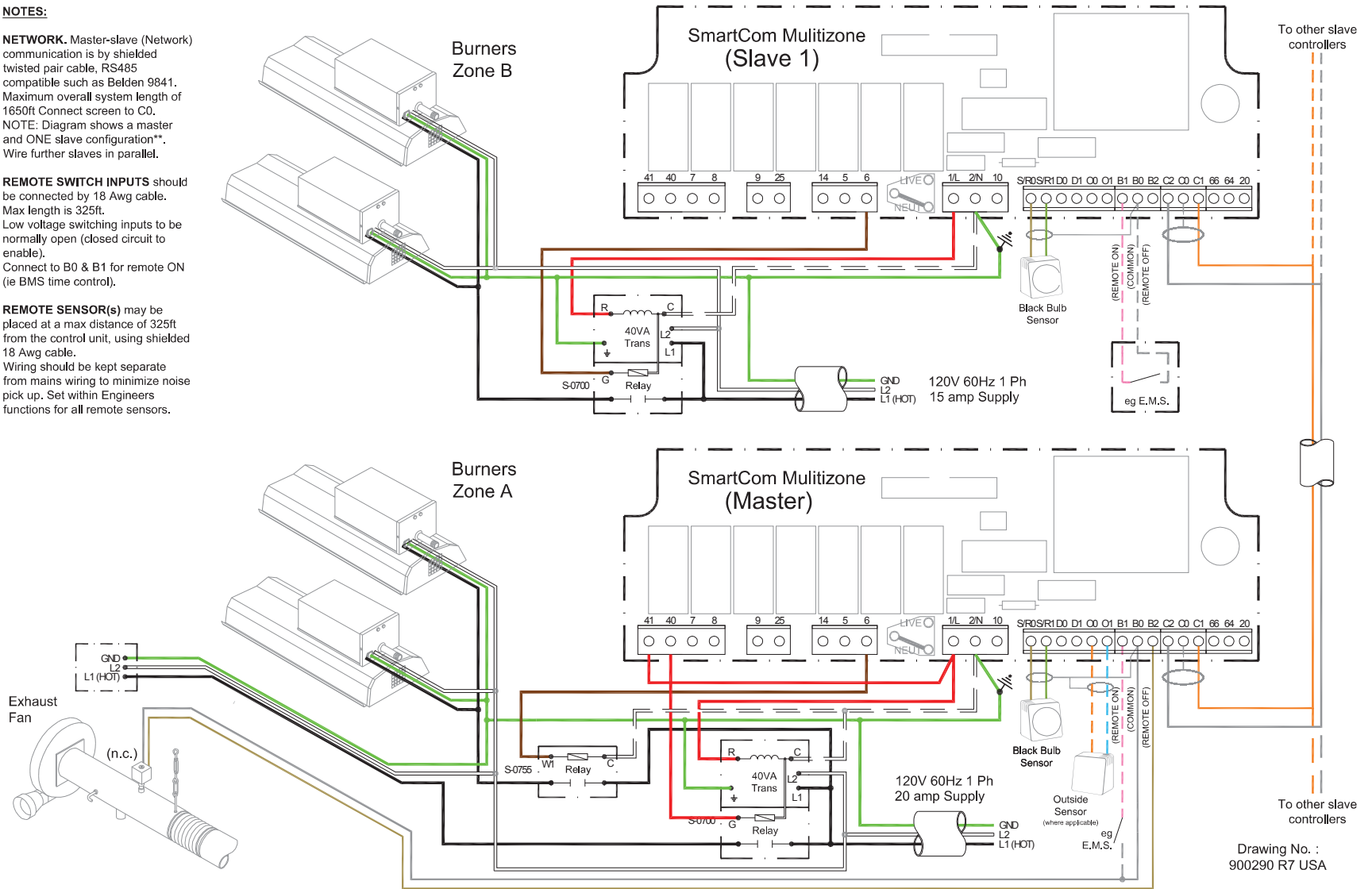


Figure 4.d. ARC Split Zone schematic interconnecting wiring (2 zones shown)

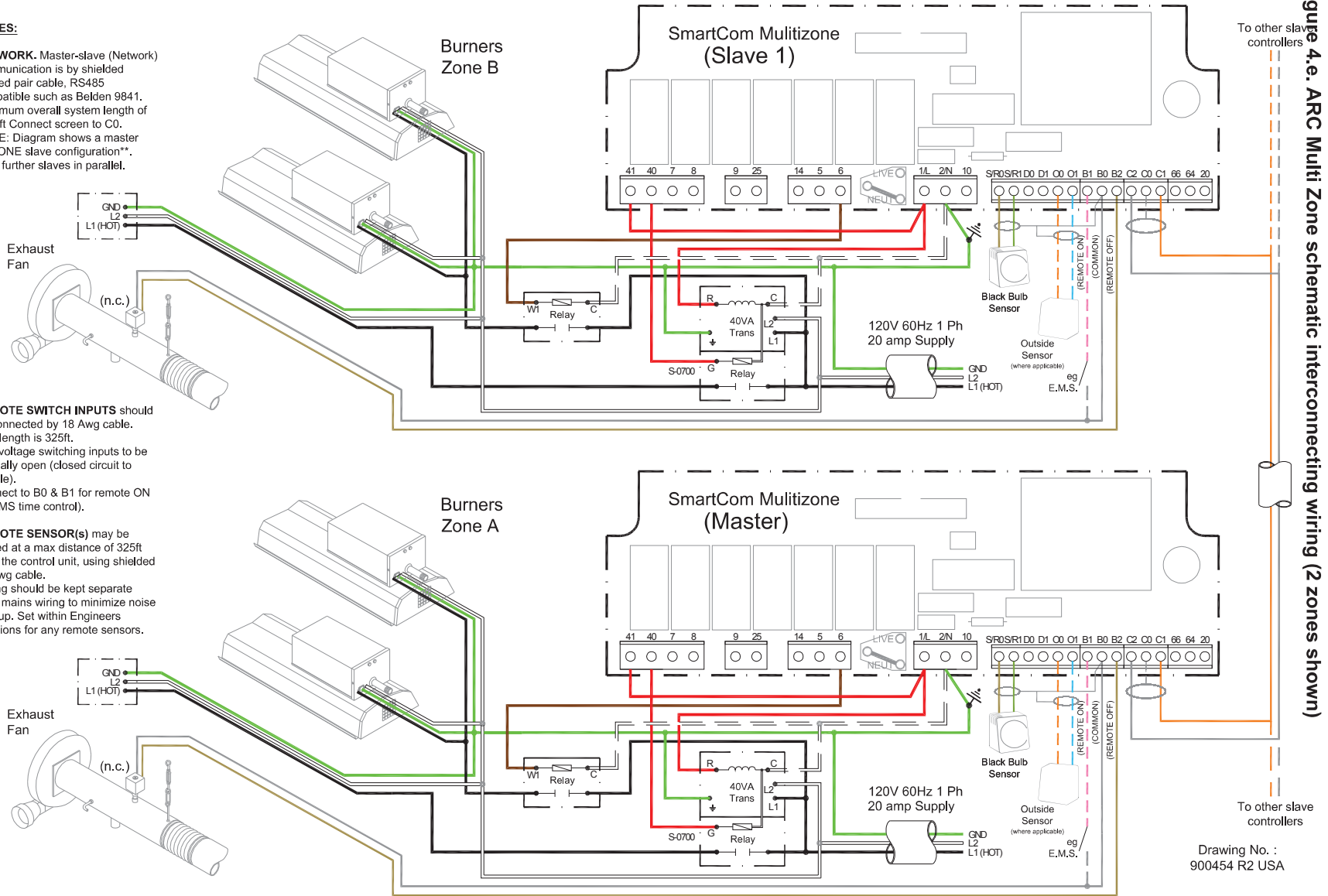
Drawing No. : 900290 R7 USA

**NOTES:**

**NETWORK.** Master-slave (Network) communication is by shielded twisted pair cable, RS485 compatible such as Belden 9841. Maximum overall system length of 1650ft Connect screen to C0.  
NOTE: Diagram shows a master and ONE slave configuration\*\*. Wire further slaves in parallel.

**REMOTE SWITCH INPUTS** should be connected by 18 Awg cable. Max length is 325ft. Low voltage switching inputs to be normally open (closed circuit to enable). Connect to B0 & B1 for remote ON (ie BMS time control).

**REMOTE SENSOR(s)** may be placed at a max distance of 325ft from the control unit, using shielded 18 Awg cable. Wiring should be kept separate from mains wiring to minimize noise pick up. Set within Engineers functions for any remote sensors.



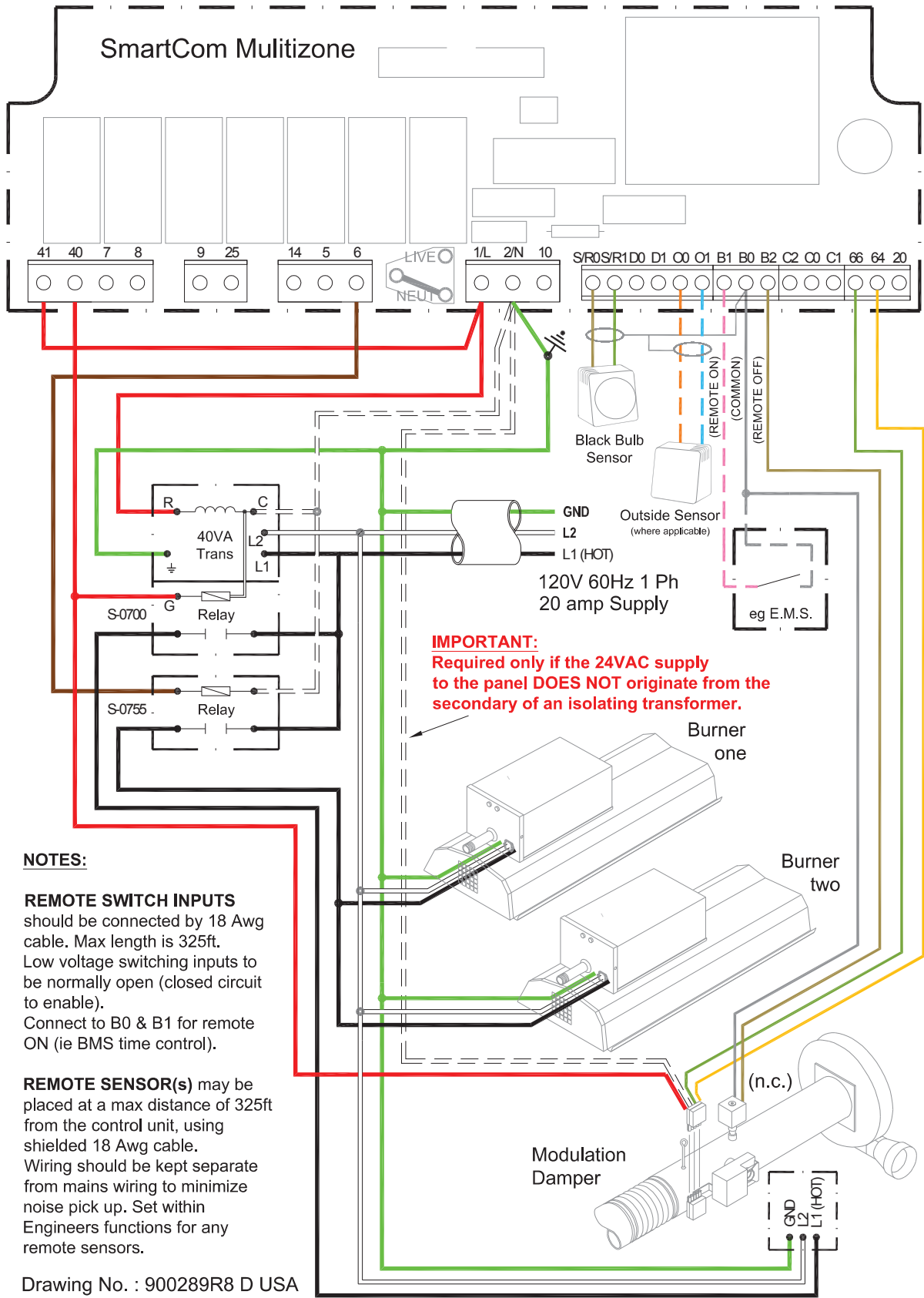
To other slave controllers

To other slave controllers

Drawing No. : 900454 R2 USA

Figure 4.e. ARC Multi Zone schematic interconnecting wiring (2 zones shown)

Figure 4.f. ARC Single Zone system c/w motorised damper schematic interconnecting wiring.



**NOTES:**

**REMOTE SWITCH INPUTS** should be connected by 18 Awg cable. Max length is 325ft. Low voltage switching inputs to be normally open (closed circuit to enable). Connect to B0 & B1 for remote ON (ie BMS time control).

**REMOTE SENSOR(s)** may be placed at a max distance of 325ft from the control unit, using shielded 18 Awg cable. Wiring should be kept separate from mains wiring to minimize noise pick up. Set within Engineers functions for any remote sensors.

Drawing No. : 900289R8 D USA

**NOTES:**

**NETWORK.** Master-slave (Network) communication is by shielded twisted pair cable, RS485 compatible such as Belden 9841. Maximum overall system length of 1650ft Connect screen to C0. NOTE: Diagram shows a master and ONE slave configuration\*\*. Wire further slaves in parallel.

**REMOTE SWITCH INPUTS** should be connected by 18 Awg cable. Max length is 325ft. Low voltage switching inputs to be normally open (closed circuit to enable). Connect to B0 & B1 for remote ON (ie BMS time control).

**REMOTE SENSOR(s)** may be placed at a max distance of 325ft from the control unit, using shielded 18 Awg cable. Wiring should be kept separate from mains wiring to minimize noise pick up. Set within Engineers functions for all remote sensors.

**IMPORTANT:**

**Cable A is only required if the 24VAC supply to the panel DOES NOT originate from the secondary of an isolating transformer.**

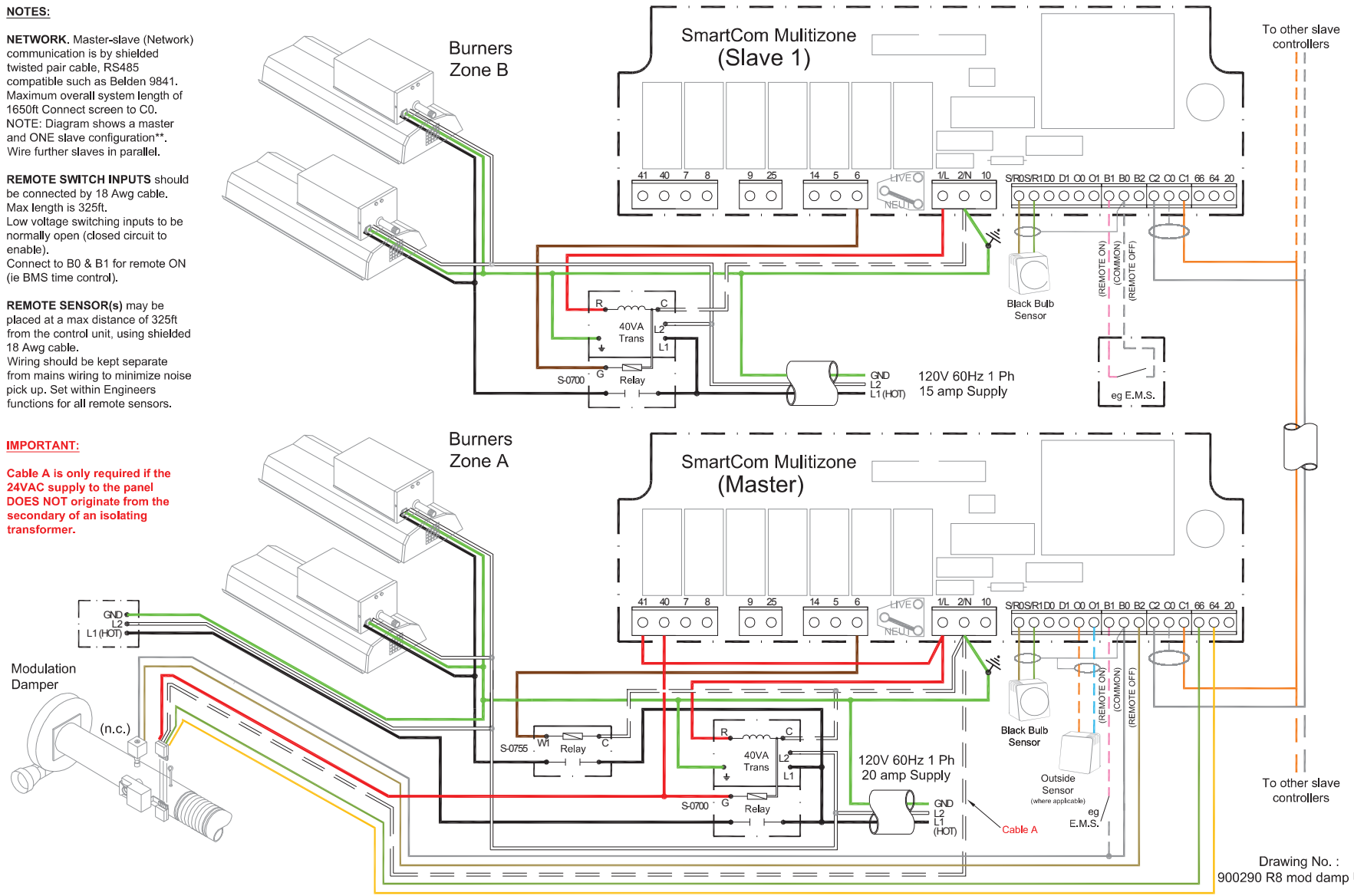


Figure 4.g. ARC Modulating Split Zone schematic interconnecting wiring (2 zones shown)

**NOTES:**

**NETWORK.** Master-slave (Network) communication is by shielded twisted pair cable, RS485 compatible such as Belden 9841. Maximum overall system length of 1650ft. Connect screen to C0. NOTE: Diagram shows a master and ONE slave configuration\*\*. Wire further slaves in parallel.

**REMOTE SWITCH INPUTS** should be connected by 18 Awg cable. Max length is 325ft. Low voltage switching inputs to be normally open (closed circuit to enable). Connect to B0 & B1 for remote ON (ie BMS time control).

**REMOTE SENSOR(s)** may be placed at a max distance of 325ft from the control unit, using shielded 18 Awg cable. Wiring should be kept separate from mains wiring to minimise noise pick up. Set within Engineers functions any for remote sensors.

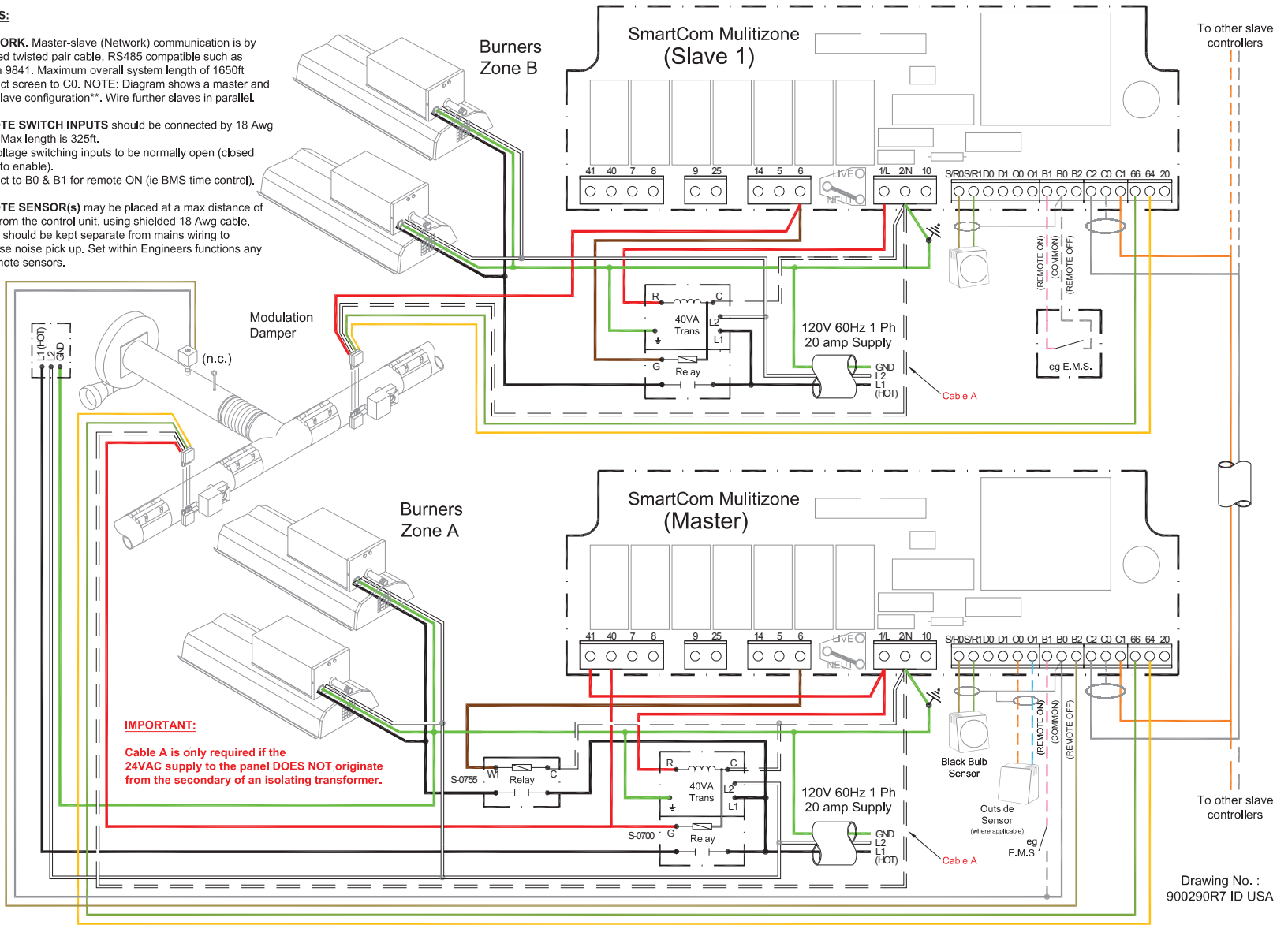


Figure 4.h. ARC Independently modulating Split Zone schematic interconnecting wiring (2 zones shown)

**NOTES:**

**NETWORK.** Master-slave (Network) communication is by shielded twisted pair cable, RS485 compatible such as Belden 9841. Maximum overall system length of 1650ft. Connect screen to C0.  
NOTE: Diagram shows a master and ONE slave configuration\*\*. Wire further slaves in parallel.

**REMOTE SWITCH INPUTS** should be connected by 18 Awg cable. Max length is 325ft. Low voltage switching inputs to be normally open (closed circuit to enable). Connect to B0 & B1 for remote ON (ie BMS time control).

**REMOTE SENSOR(s)** may be placed at a max distance of 325ft from the control unit, using shielded 18 Awg cable. Wiring should be kept separate from mains wiring to minimize noise pick up. Set within Engineers functions for any remote sensors.

**IMPORTANT:** Cable A is only required if the 24VAC supply to the panel DOES NOT originate from the secondary of an isolating transformer.

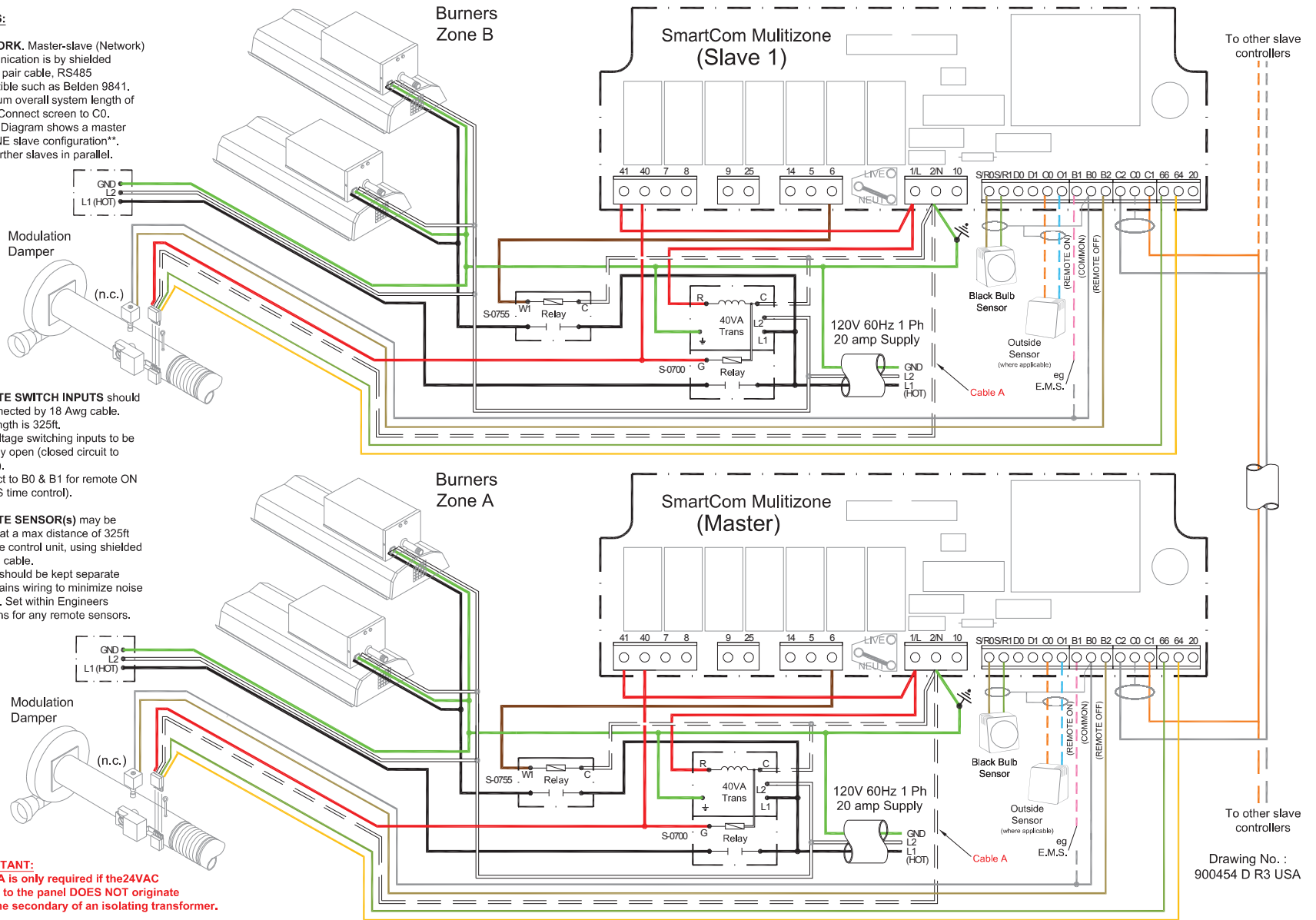
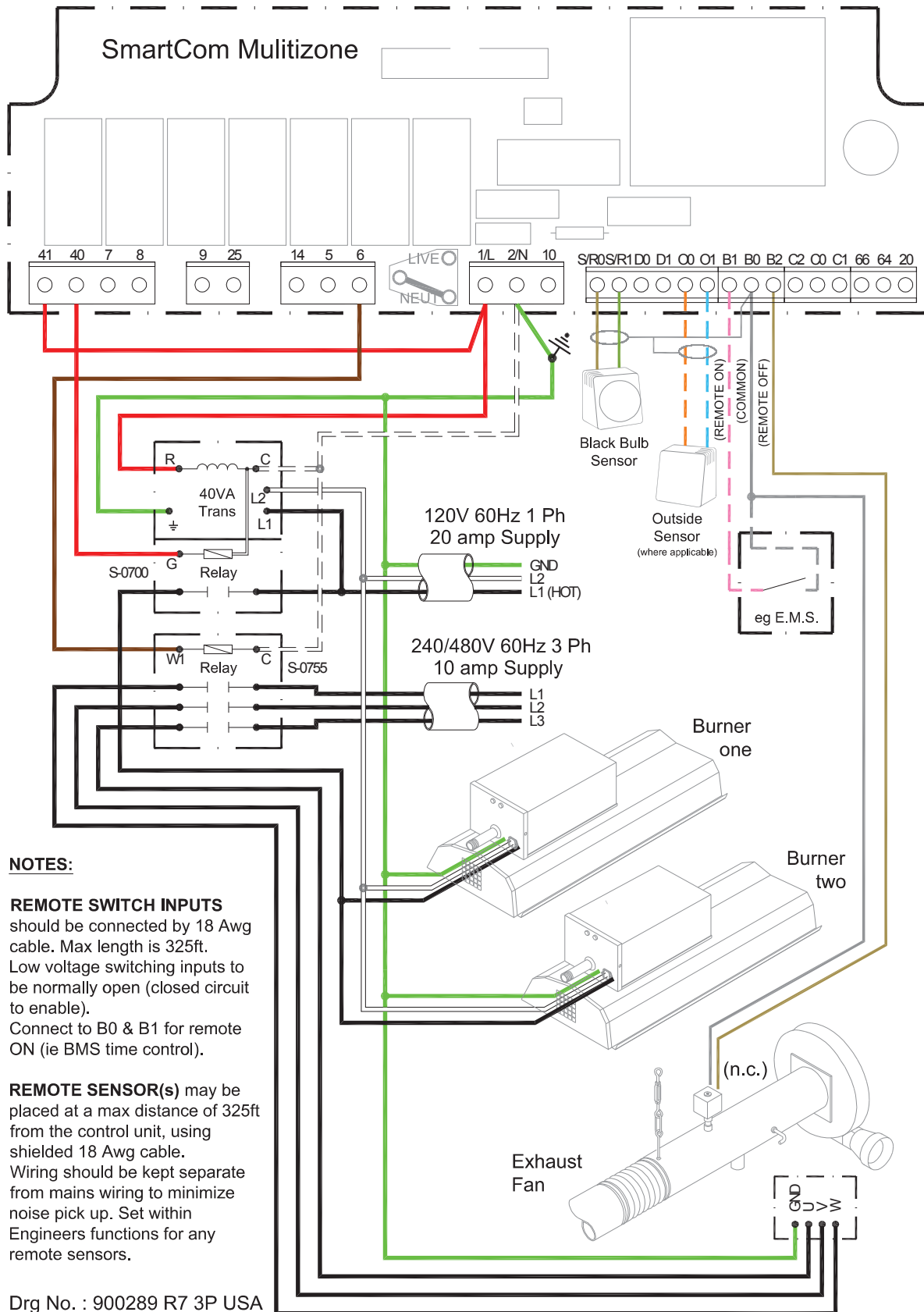


Figure 4.j: ARC modulating Multi Zone schematic interconnecting wiring (2 zones shown)



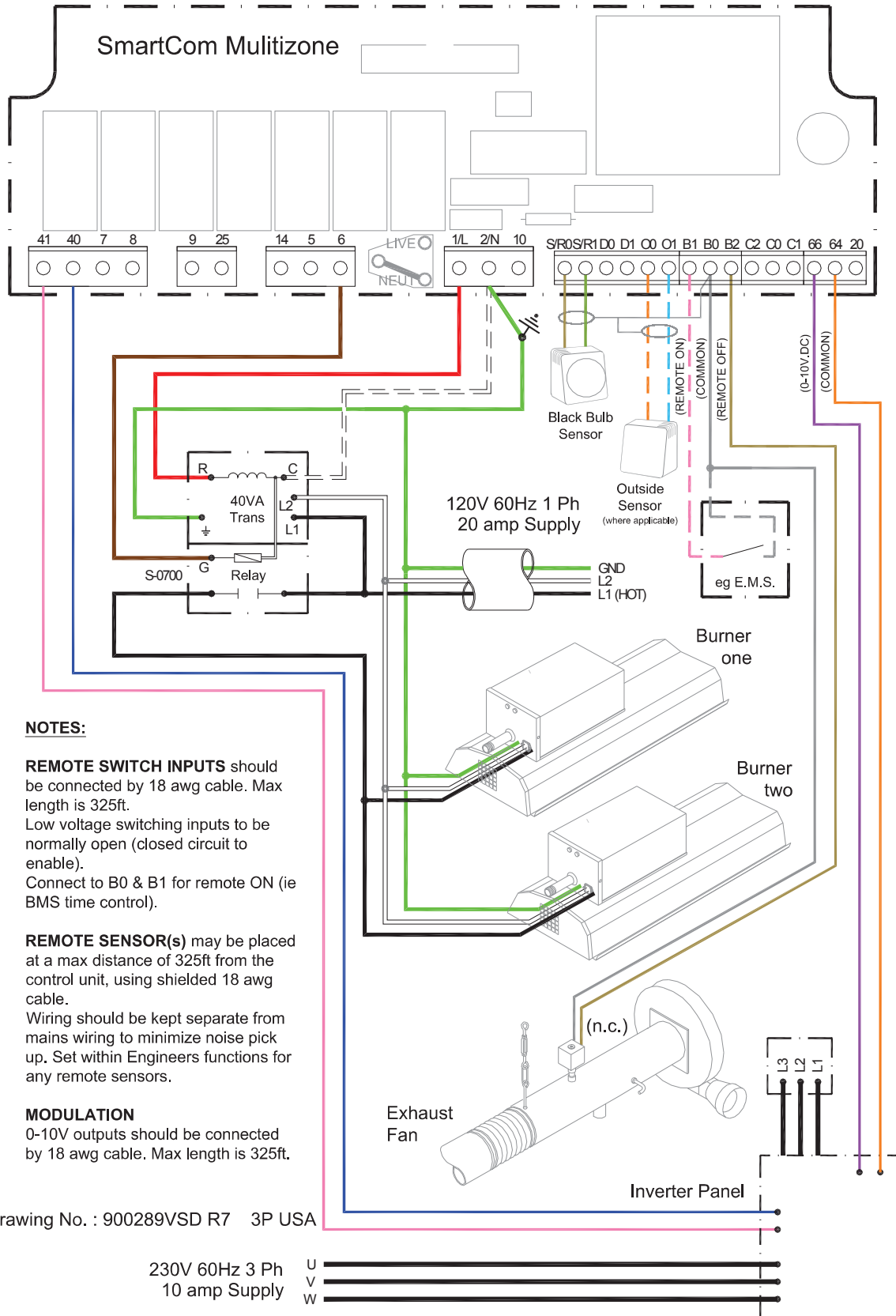
**NOTES:**

**REMOTE SWITCH INPUTS** should be connected by 18 Awg cable. Max length is 325ft. Low voltage switching inputs to be normally open (closed circuit to enable). Connect to B0 & B1 for remote ON (ie BMS time control).

**REMOTE SENSOR(s)** may be placed at a max distance of 325ft from the control unit, using shielded 18 Awg cable. Wiring should be kept separate from mains wiring to minimize noise pick up. Set within Engineers functions for any remote sensors.

Drg No. : 900289 R7 3P USA

Figure 4.I. ARC modulating Single Zone 3 phase via Inverter schematic interconnecting wiring.



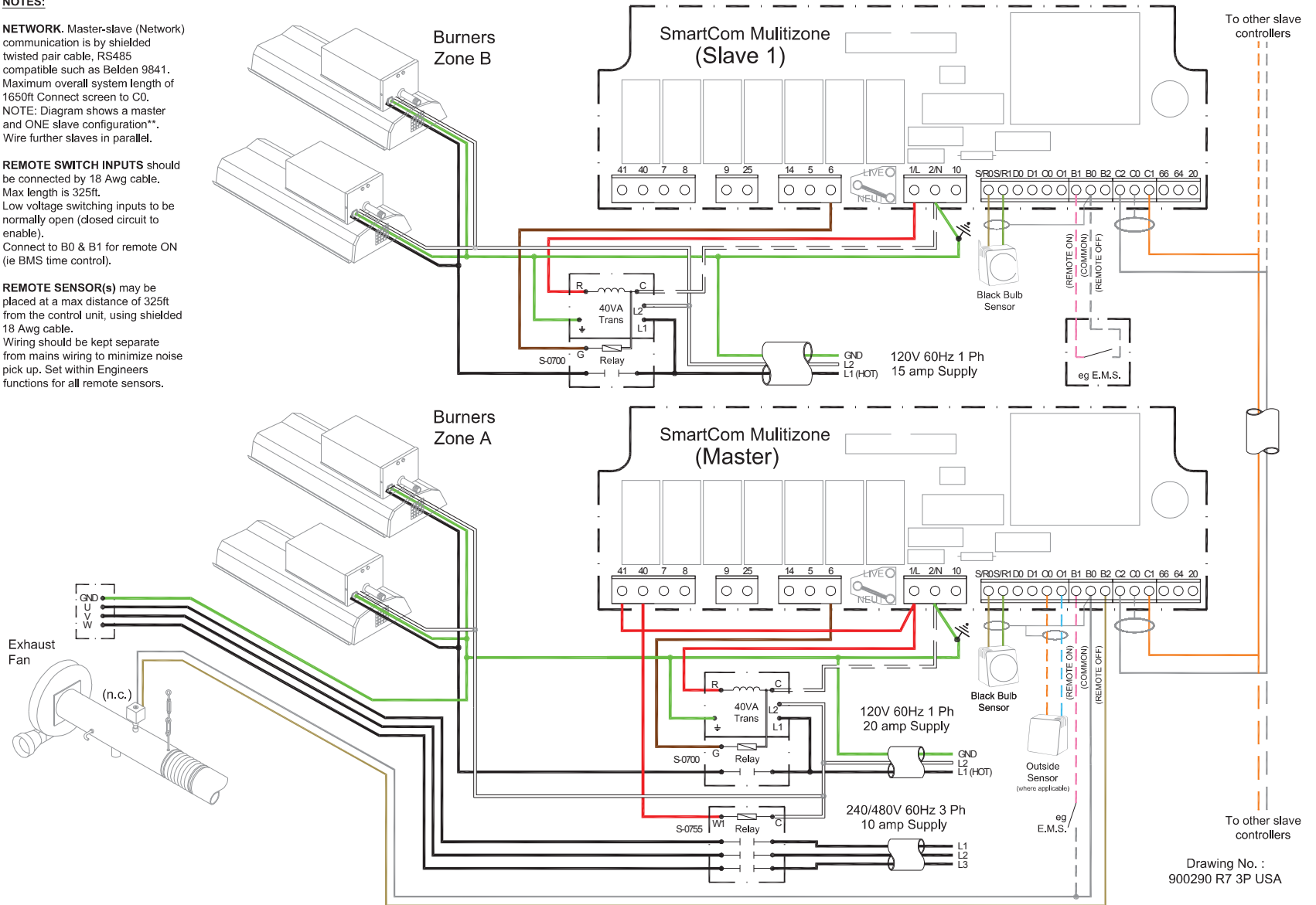


**NOTES:**

**NETWORK.** Master-slave (Network) communication is by shielded twisted pair cable, RS485 compatible such as Belden 9841. Maximum overall system length of 1650ft Connect screen to C0.  
NOTE: Diagram shows a master and ONE slave configuration\*\*. Wire further slaves in parallel.

**REMOTE SWITCH INPUTS** should be connected by 18 Awg cable. Max length is 325ft. Low voltage switching inputs to be normally open (closed circuit to enable). Connect to B0 & B1 for remote ON (ie BMS time control).

**REMOTE SENSOR(s)** may be placed at a max distance of 325ft from the control unit, using shielded 18 Awg cable. Wiring should be kept separate from mains wiring to minimize noise pick up. Set within Engineers functions for all remote sensors.



Drawing No. : 900290 R7 3P USA

Figure 4.m. ARC Split Zone 3 phase schematic interconnecting wiring (2 zones shown)

**NOTES:**

**NETWORK.** Master-slave (Network) communication is by shielded twisted pair cable, RS485 compatible such as Belden 9841. Maximum overall system length of 1650ft Connect screen to C0. NOTE: Diagram shows a master and ONE slave configuration\*\*. Wire further slaves in parallel.

**REMOTE SWITCH INPUTS** should be connected by 18 Awg cable. Max length is 325ft. Low voltage switching inputs to be normally open (dosed circuit to enable). Connect to B0 & B1 for remote ON (ie BMS time control).

**REMOTE SENSOR(s)** may be placed at a max distance of 325ft from the control unit, using shielded 18 Awg cable. Wiring should be kept separate from mains wiring to minimize noise pick up. Set within Engineers functions for all remote sensors.

**MODULATION** 0-10V outputs should be connected by 18 awg cable. Max length is 325ft.

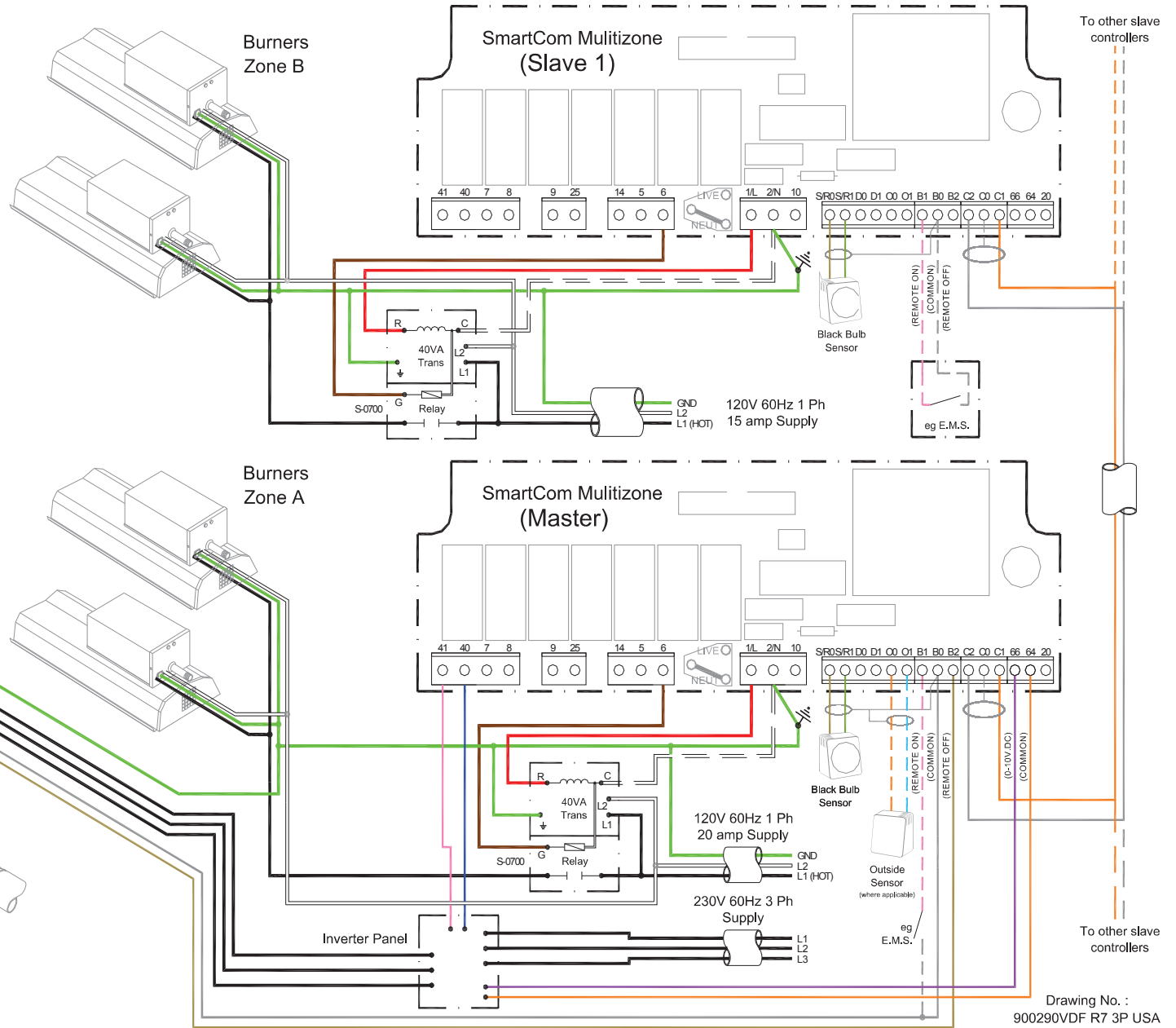


Figure 4.n. ARC Split Zone 3 phase via inverter schematic interconnecting wiring (2 zones shown)

## 1.9 Ventilation Requirements

### Considerations.

The vacuum fan must be located as shown in the layout drawing.

The vacuum fan must have a bottom horizontal discharge.

The fan should be fitted to the building structure or suspended from the roof structure, via drop rods and mounted on base frame. (Anti-vibration mountings are fitted between the fan and the mounting base frame.

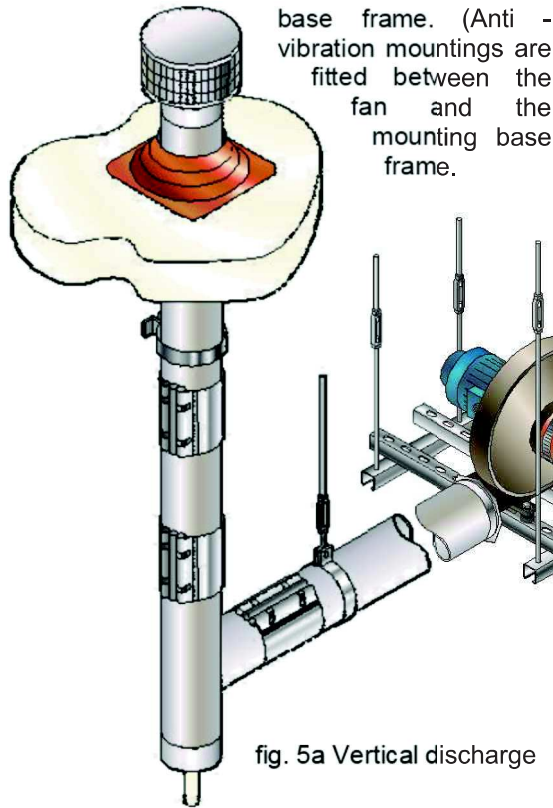


fig. 5a Vertical discharge

For full details of parts and installation, please refer to section 2.9.3

The heater can be installed with a vertical vent.

All vent piping should be adequately supported from the building structure and terminated with an approved terminal.

Distances from adjacent public walkways, adjacent buildings, openable windows and building openings, consistent

with the National Fuel Gas Code, ANSI Z223.1/ NFPA 54.

Any portion of vent that passes through a combustible wall must be insulated, or use an approved insulating thimble.

Standard vent terminals must extend at least 6" from the wall and at least 24" from any combustible overhang. Protect the building material from degradation by the vent gasses.

Vent joints should be sealed and secured using at least 3 sheet metal screws. Should condensation occur the vent should be shortened or insulated.

The terminal should be at least 3ft away from any air intake to the building.

If the heater is equipped with ducted combustion air, the vent terminal must be at least 3ft away from the air inlet and located higher than the inlet.

The vent terminal must be protected from blockage by snow.

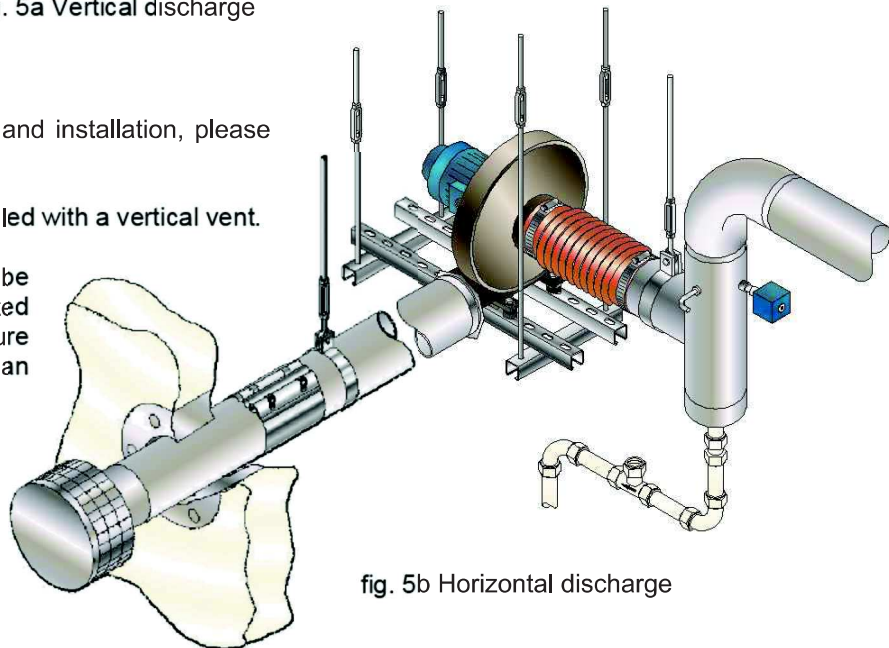


fig. 5b Horizontal discharge

### 1.10. Ducted Air Inlet Considerations.

Heat resistant flexible tube is connected to the burner assembly ducted air adaptor and the EVM ducted air adaptor and connected to the air supply duct

The maximum length of 4" diameter ductwork is 78".

Ensure that the flexible supply duct does not drape over or touch the reflector.

Ensure that the flexible ductwork is installed to allow for expansion of the heating system.

On a header duct, the main air supply header which is feeding the individual branch ducts and burner/end vent supply ducts must have a maximum pressure drop of 0.25 mbar (0.1 in w.c.).

All joints and seams in the air supply system must be made air tight and a bird screen used at the inlet.

For full details refer to section 2.13

Figure 6a. Header Duct Connection

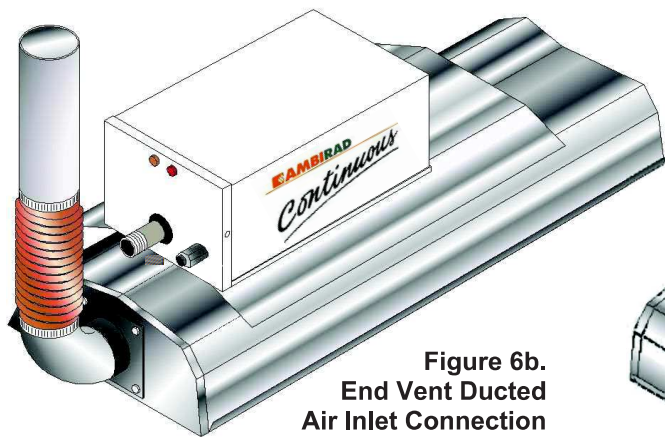
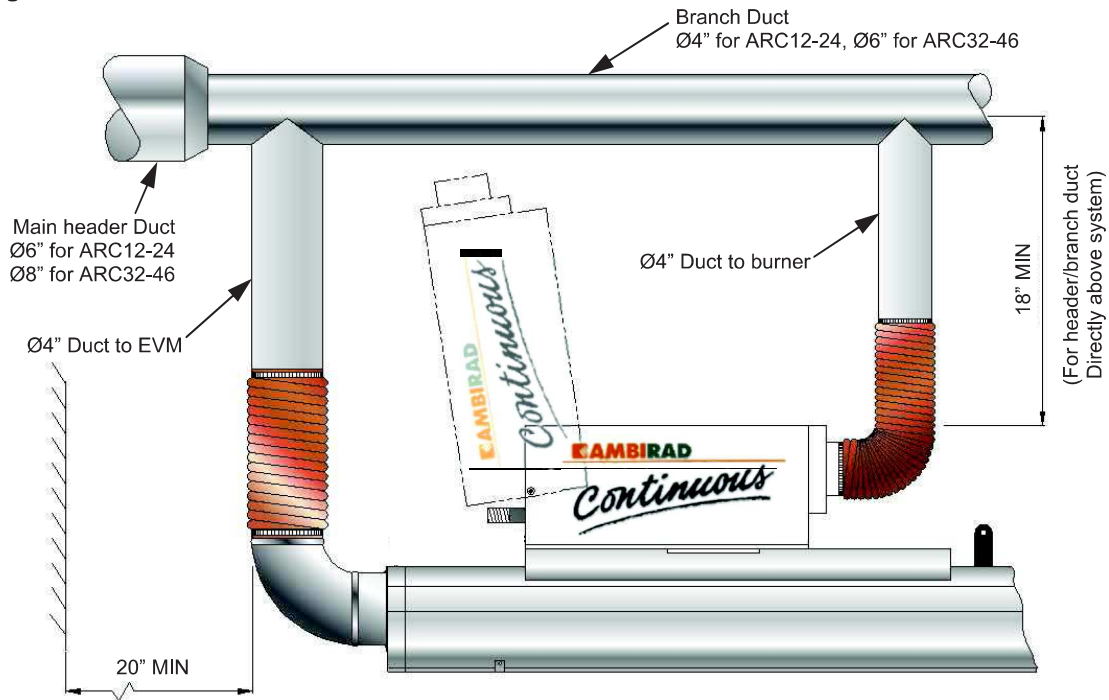


Figure 6b.  
End Vent Ducted  
Air Inlet Connection

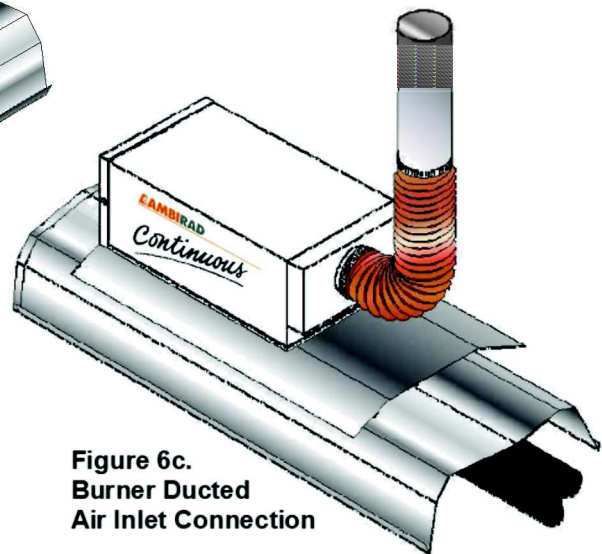


Figure 6c.  
Burner Ducted  
Air Inlet Connection

### 1.11 Vacuum fan mounting details (Type 'F200NA' fan illustrated)

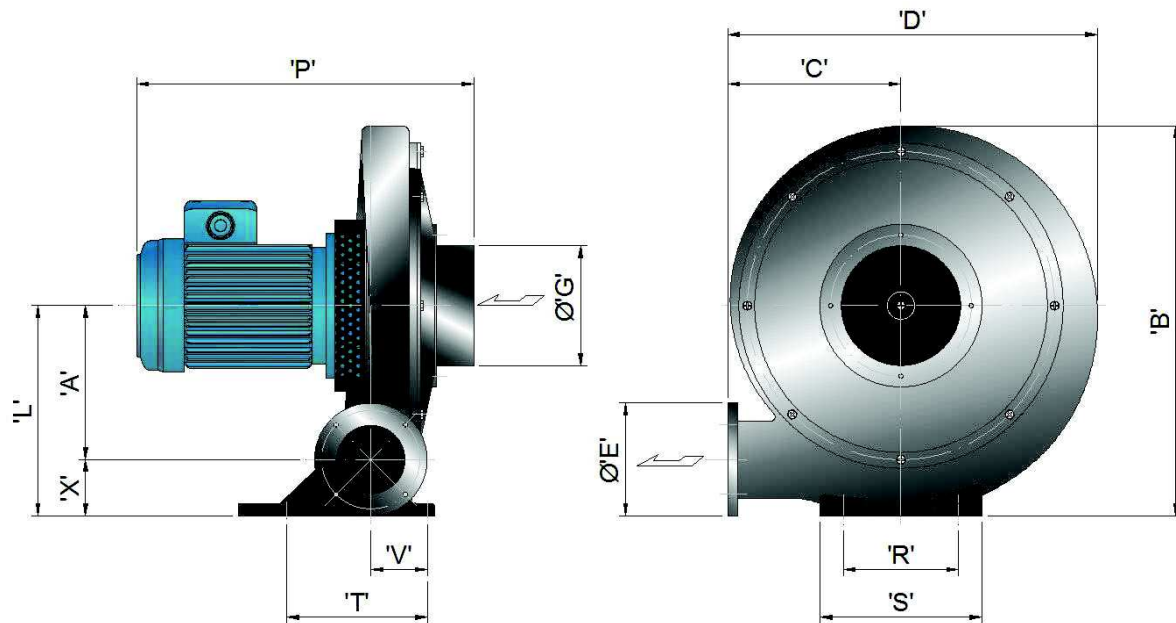


Table 4. Vacuum fan dimensions

Fan Size	F100NA	F200NA(3P)	F300NA
A (crs)	5.1"	5.9"	7.2"
B	14.6"	16.9"	19.9"
C	6.7"	8.0"	8.3"
D	14.0"	17.0"	17.9"
E (Ø)	3.7"	4.3"	6.0"
G (Ø)	4"	5"	5"
L	7.7"	9.0"	10.9"
P	13.5	15.4"	17.0"
R (crs)	5.3"	5.3"	5.4"
S (crs)	7.3"	7.5"	9.0"
T	5.3"	6.5"	4.0"
V	1.8"	2.2"	2.8"
X	2.6"	3.1"	3.6"

**1.12 Technical Details.**  
**Tables 5a Burner Details**

No of Injectors	1
Gas Connection	½" N.P.T Internal thread
Burner current	0.1 (per burner)
Electrical Voltage/Ph/Hz	120 volt 1 phase 60Hz

Burner Type	12LR	18LR	24LR	32LR	38LR	46LR
-------------	------	------	------	------	------	------

**Burner Details**

Natural Gas	Heat input (Gross)	Btu/h	41,000	61,000	82,000	109,000	130,000	157,000
	Gas consumption rate Nat Gas	ft <sup>3</sup> /h	40.5	60.8	81.1	106.4	126.4	153.0
	Max Inlet pressure Nat Gas	w.c.	12					
	Min Inlet Pressure Nat Gas	w.c.	4.8					
	Injector size Nat Gas*	mm	3.6	4.4	4.9	5.4	5.8	6.3
	Injector Part No.*		L100336	L100544	L100549	L100554	L100558	L100563
	Air shutter size Nat Gas*	mm	13	17	19.5	22.0	24.0	26.5
	Air shutter Part No.*		L100322	L100321	L100320	L100314	L100316	L100318

**Tables 5b Burner Details**

Burner Type	12LR	18LR	24LR	32LR	38LR	46LR
-------------	------	------	------	------	------	------

**Burner Details**

Propane Gas	0-2000 ft	Heat input (Gross)	Btu/h	41,000	61,000	82,000	109,000	130,000	157,000
		Gas consum rate Propane	ft <sup>3</sup> /h	16.4	24.6	32.8	43.0	51.1	61.8
		Max Inlet pressure Propane	w.c.	12					
		Min Inlet Pressure Propane	w.c.	4.8					
		Injector size Propane**	mm	2.9	3.5	4.0	4.4	4.8	5.2
		Injector Part No.**		L100529	L100535	L100540	L100544	L100548	L100552
		Air shutter size Propane**	mm	13	17	19.5	22.0	24.0	26.5
		Air shutter Part No.**		L100322	L100321	L100320	L100314	L100316	L100318
	2001-6500 ft	Injector size Propane**	mm	2.6	3.2	3.7	4.0	4.4	4.8
		Injector Part No.**		L100526	L100532	L100537	L100540	L100544	L100548
		Air shutter size Propane**	mm	13	17	19.5	22.0	24.0	26.5
		Air shutter Part No.**		L100322	L100321	L100320	L100314	L100316	L100318
	6501-8500 ft	Injector size Propane**	mm	2.5	3.1	3.5	3.9	4.2	4.6
		Injector Part No.**		L100525	L100531	L100535	L100539	L100542	L100546
		Air shutter size Propane**	mm	13	17	19.5	22.0	24.0	26.5
		Air shutter Part No.**		L100322	L100321	L100320	L100314	L100316	L100318

\* Altitude adjustment - heat input reduced naturally without adjustment by - 4% per 1000 ft (assuming natural gas is 1041 Btu/ft<sup>3</sup> at 1015 mbar atmospheric pressure)

**Tables 5c. Heat inputs and gas consumptions for modulation heaters**

			<b>Burner Type</b>	<b>18LR</b>	<b>24LR</b>	<b>32LR</b>	<b>38LR</b>
<b>Burner Details</b>							
	Heat input - LOW Fire (Gross)	Btu/h	30,000	39,000	52,000	63,000	
	Heat input - HIGH Fire (Gross)	Btu/h	74,000	98,000	130,000	155,000	
<b>Natural Gas</b>	Gas consumption rate HIGH Fire	ft <sup>3</sup> /h	76	101	133	159	
	Gas consumption rate LOW Fire	ft <sup>3</sup> /h	31	40	53	65	
<b>Propane Gas</b>	Gas consumption rate HIGH Fire	ft <sup>3</sup> /h	31	41	54	65	
	Gas consumption rate LOW Fire	ft <sup>3</sup> /h	13	16	22	26	

**Table 6. Heater Details**

<b>Burner Type</b>		<b>12LR</b>	<b>18LR</b>	<b>24LR</b>	<b>32LR</b>	<b>38LR</b>	<b>46LR</b>
Min distance between burners	ft	17	24	31	46	59	75
Max distance between burners	ft	24	34	43	59	75	88
Min distance between burner and fitting	ft	12	12	16	20	23	27
Max tube temp	°F	850			900		
Min mounting height	ft	10	12	13	15	18	20
Max burners per branch		5	4	3	3	3	3

**Table 7. Burner Dip-switch position**

		<b>Number (qty) of burners in-line</b>				
(see section 3.3.1.8)		<b>1</b>	<b>2</b>	<b>3</b>	<b>4</b>	<b>5</b>
<b>Burner Number</b> (within each radiant branch - lowest number closest to fan)	1	1	1	1	1	1
	2	-	2	2	2	1
	3	-	-	3	3	2
	4	-	-	-	4	3
	5	-	-	-	-	4

To set dip-switch slide the white switch toward the numbers (1-4)

**Table 8. Burner Noise Data**

<b>Burner Type</b>		<b>12LR</b>	<b>18LR</b>	<b>24LR</b>	<b>32LR</b>	<b>38LR</b>	<b>46LR</b>
Noise level @ 10ft below <b>In-Line BURNER</b>	db(A)	46	47	47	48	50	51
	NR±2	40	41	41	42	44	45
Noise level @ 10ft below <b>EVM Burner</b>	db(A)	46	48	48	52	55	58
	NR±2	40	42	42	46	49	52
Noise level @ 10ft below <b>EVM with silencer</b>	db(A)	44	45	45	48	51	53
	NR±2	38	39	39	42	45	47
Noise level @ 10ft below <b>EVM Burner with Ducted Air</b>	db(A)	tba	tba	tba	tba	tba	tba
	NR±2	tba	tba	tba	tba	tba	tba

**Table 9. Fan Details**

Fan Size/part number		F100NA	F200NA	F200NA3P	F200NA3P480	F300NA
Fan ref		202074	202073			202072
Motor ref		CX-75SAH	CX-75AH	CX-75AH	CX-75AH	CX-100AH
Power	kw/hp	0.4/0.5	0.75/1.0	0.75/1.0	0.75/1.0	1.5/2.0
Supply to Fan	V/Hz/P	115/230~60/1	115/230~60/1	208-220~60/3	480~60/3	230/460~60/3
Run Current	A	4.5/2.7	9.0/4.5	3.0/1.9	3.0/1.9	5.5/3.5
Speed	RPM	3500	3500	3500	3500	3500
Wired		Δ	Δ	Δ	Δ	人
Air Flow (max)	cfm	280	630	630	630	805
Noise Data	db	56	64	64	64	74
Pressure	in w.c.	6.3	10.6	10.6	10.6	12.6
Max Operating Temp.	°F	392	392	392	392	392
Weight	lb	22	52	42	42	60
Inlet	in Ø	4	4	5	5	5
Outlet	in Ø	4	5	5	5	5

**Table 10. System Weights**

Burner Type	12LR	18LR	24LR	32LR	38LR	46LR
LR Burner	lb					14.2
Radiant branch*	lb/ft					5.6
Radiant branch + Slimline grille*	lb/ft					7.3
Radiant branch + Protective guard*	lb/ft					6.7
4" Mild steel tail pipe	lb/ft					3.7
4" Aluminum tail pipe	lb/ft					0.6
6" Mild steel tail pipe	lb/ft					7.1
6" Aluminium tail pipe	lb/ft					0.9
Max / susp point @ EV position	lb					55

\* without burners or ducted air systems



## 2. Assembly Instructions

**i** PLEASE READ this section prior to assembly to familiarise yourself with the components and tools you require at the various stages of assembly. Carefully open the packaging and check the contents against the parts and check list.

**The manufacturer reserves the right to alter specifications without prior notice.**

**i** Please ensure that all packaging is disposed of in a safe environmentally friendly way.

**i** For your own safety we recommend the use of safety boots and leather faced gloves when handling sharp or heavy items. The use of protective eye wear is also recommended.

### 2.1 Tools Required.

The following tools and equipment are advisable to complete the tasks laid out in this manual.

**i** Suitable alternative tools may be used.



### 2.2 Assembly Notes.

**!** Please read these assembly notes in conjunction with the correct assembly drawings (Sections 2.2.1 to 2.18.1)

**!** The system is assembled at high level suspended by chains from first fixings to the roof structure. (First fixings by others)

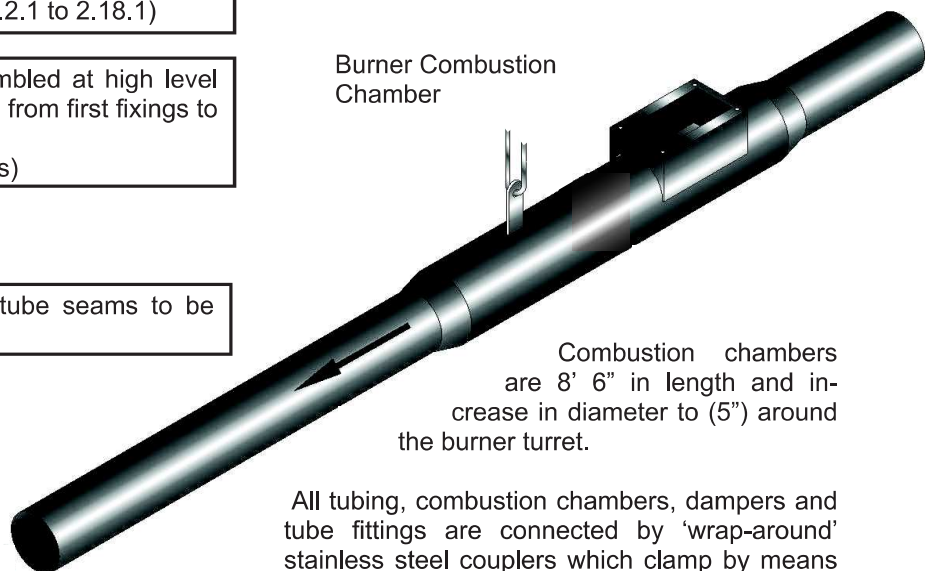
#### 2.2.1 Radiant Tubes

**!** Note: on assembly, tube seams to be facing upwards.

All radiant tubes are 4" O/D black mild steel, aluminised steel or schedule 40 iron pipe.

These may need to be cut depending on the system drawing design.

Burner Combustion Chamber



Combustion chambers are 8' 6" in length and increase in diameter to (5") around the burner turret.

All tubing, combustion chambers, dampers and tube fittings are connected by 'wrap-around' stainless steel couplers which clamp by means of two high tensile stainless steel set pins. (See section 2.2.2)

## 2.2.2 Couplers

The ARC Tube Coupler is a screw tightening, self aligning - positive located tubular coupler. Manufactured in a stainless steel it is available in both 100mm (4") and 150mm (6").

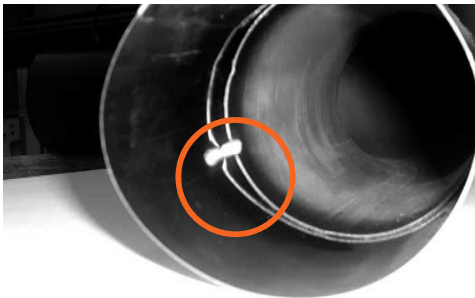
Two high tensile stainless steel set pins tighten to clamp the coupler onto the tube whilst a rivet provides a centralised permanent stop to give the joint equidistance.

The following procedure explains the correct method of assembly:

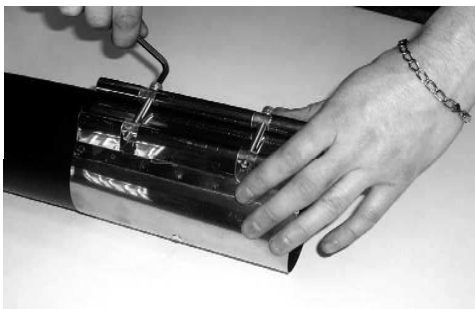
Before assembly, carefully loosen the two screws. Position the coupler onto the first tube ensuring that the bars are positioned uppermost.



Slide the coupler over the tube ensuring that the rivet stop has butted up to the tube end.



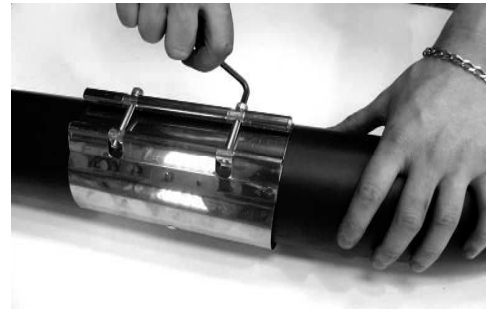
Using a 1/4" allen wrench, tighten the relevant pin. DO NOT OVERTIGHTEN.



Slide the second tube into the coupler ensuring that the rivet stop has butted up to the tube end.



Using the 1/4" allen wrench, tighten the second pin. DO NOT OVERTIGHTEN.



Moving between the two set pins, tighten both ensuring that equal pressure is applied to each set pin in turn.



If all steps have been followed correctly, the coupler should have aligned itself parallel to the two tubes and a slight indentation can be observed. Using the 1/4" allen wrench, finally tighten each screw by a further quarter turn. If a power tool is used, use a torque limit setting of 6.6 lbf/ft (0.91kgf/m) must be achieved.



### 2.2.3 Reflectors

The radiant tube sections of the system are fitted with reflectors made of either aluminum, stainless steel or aludip to direct infra-red rays downwards.

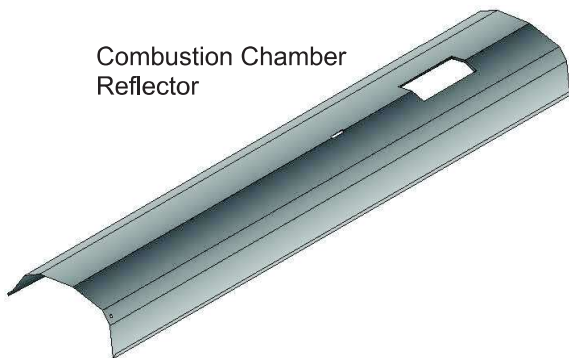
The reflectors have a unique design profile to maximise the reflected radiant heat, minimise convective loss, and maximise on rigidity.

The reflectors are overlapped and held in position by the reflector bracket assembly.

There are two styles of reflectors:

#### 2.2.3.1 Standard Reflectors


These 10' long reflectors are positioned above the tube to radiate the heat downwards and are fixed to the radiant tube via a reflector bracket (see section 2.5). The 8ft combustion chamber reflector has a rectangular hole and slot, pre cut to allow for burner combustion chamber and support lug fitting.



#### 2.2.3.2 Perimeter Reflectors

Perimeter reflectors are used when the radiant tube is mounted at the perimeter of the building. They have the same profile as standard reflectors but extended one side to direct the radiant heat away from the wall.

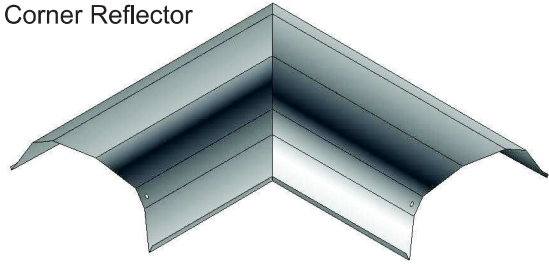
The perimeter combustion chamber reflectors have a cut-out for the combustion chamber turret and suspension lug at both ends so that the one reflector can be used for either left or right hand perimeter systems.

 Note: when overlapping the perimeter combustion chamber reflector, extra overlap is required to cover the pre-cut holes and slot.

#### 2.2.3.3 Corner Reflectors

Used where radiant tubes are joined with a 90° bend. The corner reflector comes in two pieces and is assembled on-site.

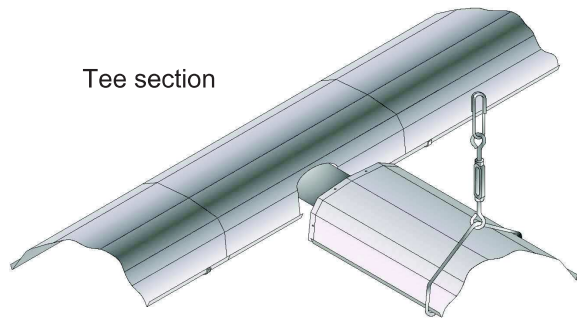
Corner Reflector



#### 2.2.3.4 Tee piece Reflectors

Used where a radiant tube connects to another at right angles. The reflector is a special short section with a central tube cut out.

Tee section

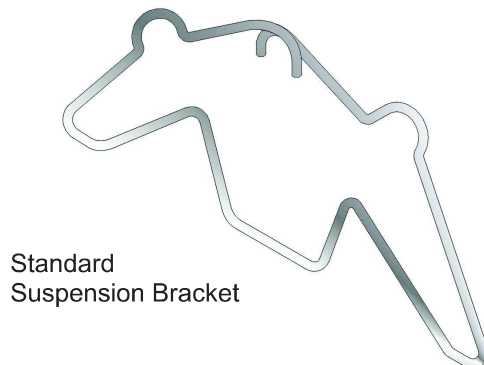


### 2.2.4 Brackets

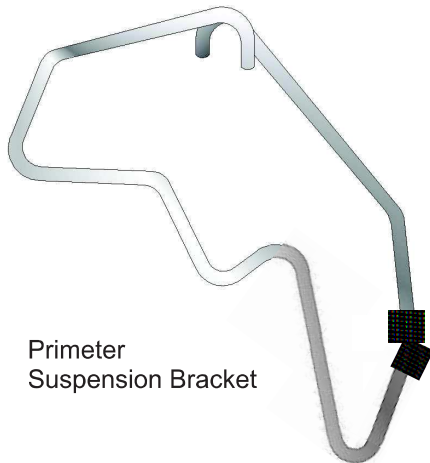
There are two styles of brackets:

#### 2.2.4.1 Suspension brackets.

Suspension brackets are made from a one piece construction and are formed to support the tube and reflector alike. The wrap around ends are aligned to hold a turnbuckle eyelet in the correct hanging position.



A perimeter suspension bracket is available which has the same profile as the standard brackets but extended one side to accommodate the perimeter reflector.



Perimeter Suspension Bracket

### 2.2.4.2 Reflector Support Bracket

Reflector Support Brackets are a two piece construction. The first half is formed to seat on top of the radiant tube and supports the reflector sides in position. The second part clamps around the bottom half of the tube and is fixed in position via a fastener.

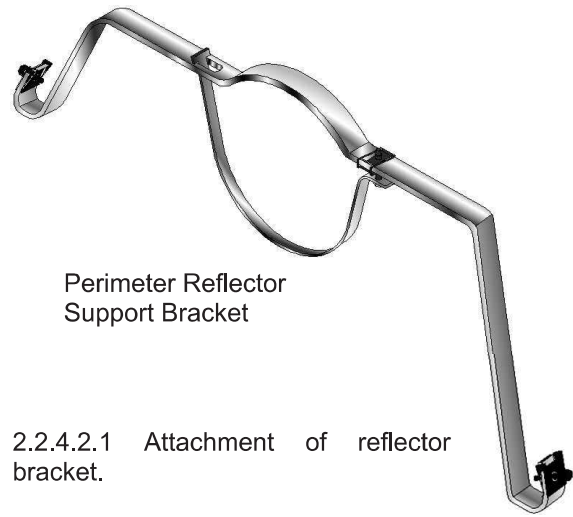


Standard Reflector Support Bracket

The reflector support bracket has two functions depending on the position of the fixing screws.

1. To fix the reflector into position.
2. To allow the reflector to slide within the bracket for thermal expansion.

A perimeter reflector support bracket is available which has the same profile as the standard brackets but extended one side to accommodate the perimeter reflector.

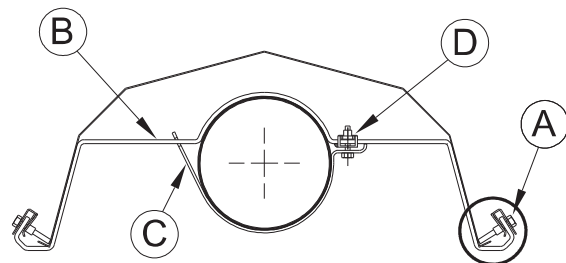


Perimeter Reflector Support Bracket

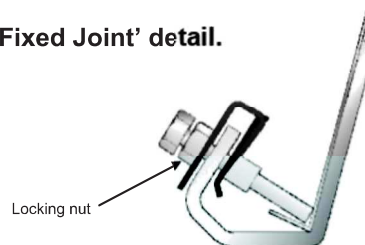
#### 2.2.4.2.1 Attachment of reflector bracket.

Fit the reflector bracket (B) around the tube and tighten the set pin (D) to clamp the central clip (C) to the tube.

The set pins (A) positioned at both edges of the bracket (B) are used to provide either a fixed joint or a sliding joint.

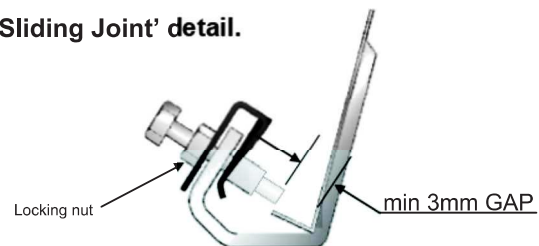


#### 'Fixed Joint' detail.



Fully tighten these screws for **fixed joints**.

#### 'Sliding Joint' detail.



Leave a minimum 3mm gap clearance between reflector and screws for a **sliding joint**.

The reflector overlap after each burner must be a 'sliding joint', to allow for thermal expansion.

The next downstream reflector overlap must be a 'fixed joint'.

This pattern of alternate sliding and fixed joints will continue up to the next in line burner or damper assembly.

■ **A reflector support bracket must be positioned at the end vent and at the damper end of each radiant branch, plus either side of a reflector corner and reflector tee section.**

**These units must be 'fixed joints'.**

## 2.2.5 Burner

### 2.2.5.1 LR Burner Unit

Each burner will consist of:

A burner control housing (BCH) of chassis style with detachable pivoting lid. All control wiring to the burner head is within the BCH, which also contains a combination gas valve comprising of 2 class 2 solenoid valves, dedicated zero governor and filter, a full sequence controller and cassette air filter for primary air supply to the burner. Externally on the BCH, neon lights indicate **main on** and **burner on** modes.

The air and gas are pre-mixed to stoichiometric proportions within the burner head assembly, prior to being admitted to the point of combustion.

Ignition is by an electric arc forward of the face of the burner head on to the main frame.



LR Burner

### 2.2.5.2 Burner Head

A burner head assembly of lightweight cast aluminium construction, a ceramic style burner head insert, maintained in position by the flame retention grid. The casting assembly also accommodates the gas jet, air shutter and mixing chamber.

The ignition and flame sensing electrode

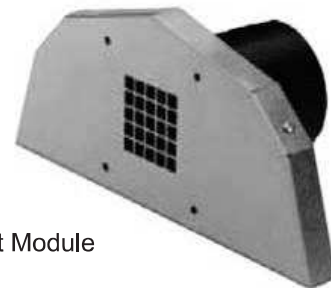
LR Burner head



assembly is mounted to the casting flange of the burner face.

## 2.2.6 End Vent Module (EVM)

At the start of each radiant branch an end vent module is connected to the rear of the first combustion chamber. The end vent module externally maintains the lines of the reflector profile.



End Vent Module

## 2.2.7 Vacuum fans

A low noise robust steel plate fabricated centrifugal fan coated with heat and corrosion resistant paint, capable of a static pressure of either 5.5 in w.c. or 7.5 in w.c. at 68°F and directly coupled to a totally enclosed motor to be fitted at the end of the tube system.

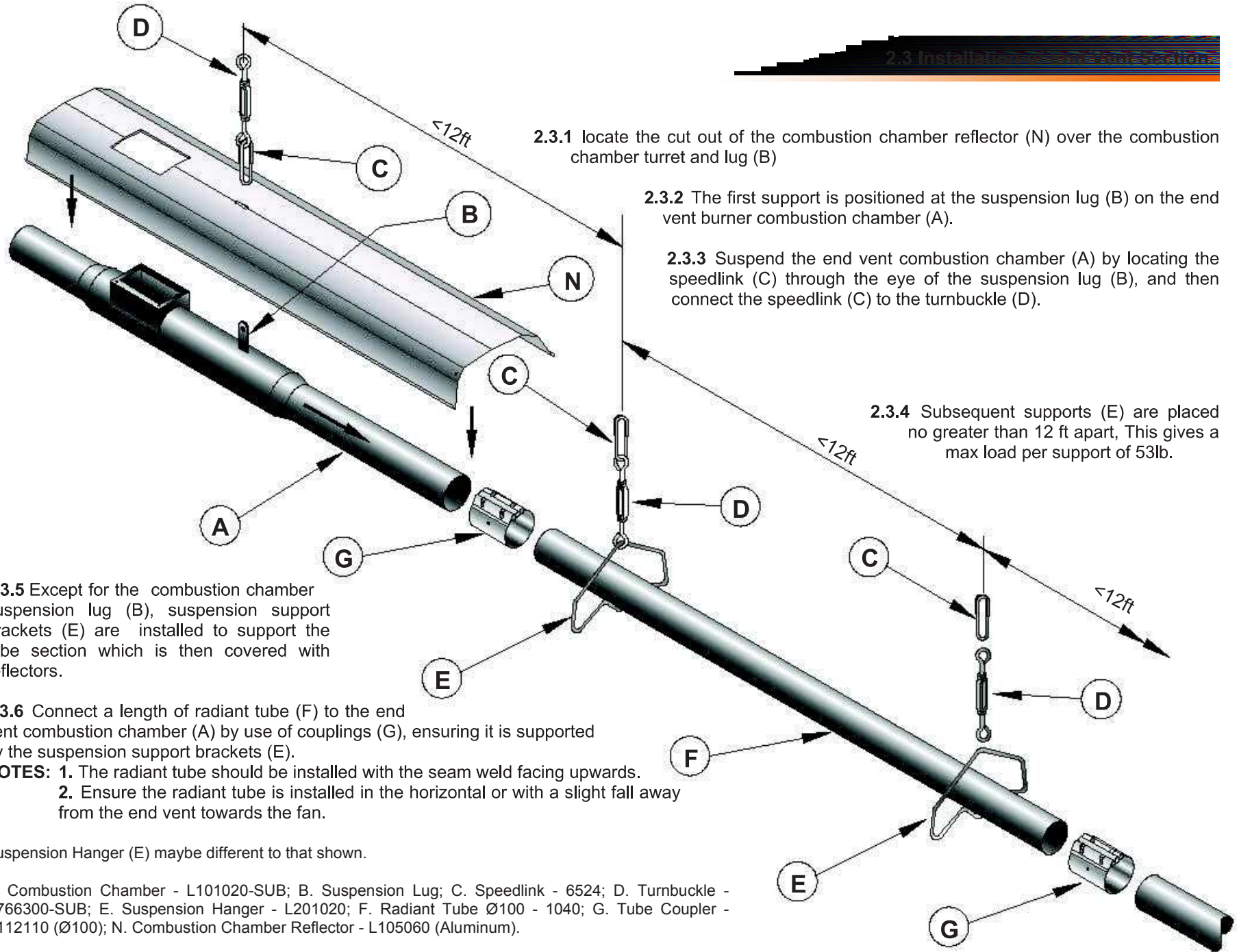
The fan exhausts the products of combustion from the system discharging through an outlet flue pipe to atmosphere external to the building.

The maximum operating temperature is 400°F.

The fan motor is IP55 rated for external use.



Exhaust Fan



**2.3.1** locate the cut out of the combustion chamber reflector (N) over the combustion chamber turret and lug (B)

**2.3.2** The first support is positioned at the suspension lug (B) on the end vent burner combustion chamber (A).

**2.3.3** Suspend the end vent combustion chamber (A) by locating the speedlink (C) through the eye of the suspension lug (B), and then connect the speedlink (C) to the turnbuckle (D).

**2.3.4** Subsequent supports (E) are placed no greater than 12 ft apart, This gives a max load per support of 53lb.

**2.3.5** Except for the combustion chamber suspension lug (B), suspension support brackets (E) are installed to support the tube section which is then covered with reflectors.

**2.3.6** Connect a length of radiant tube (F) to the end vent combustion chamber (A) by use of couplings (G), ensuring it is supported by the suspension support brackets (E).

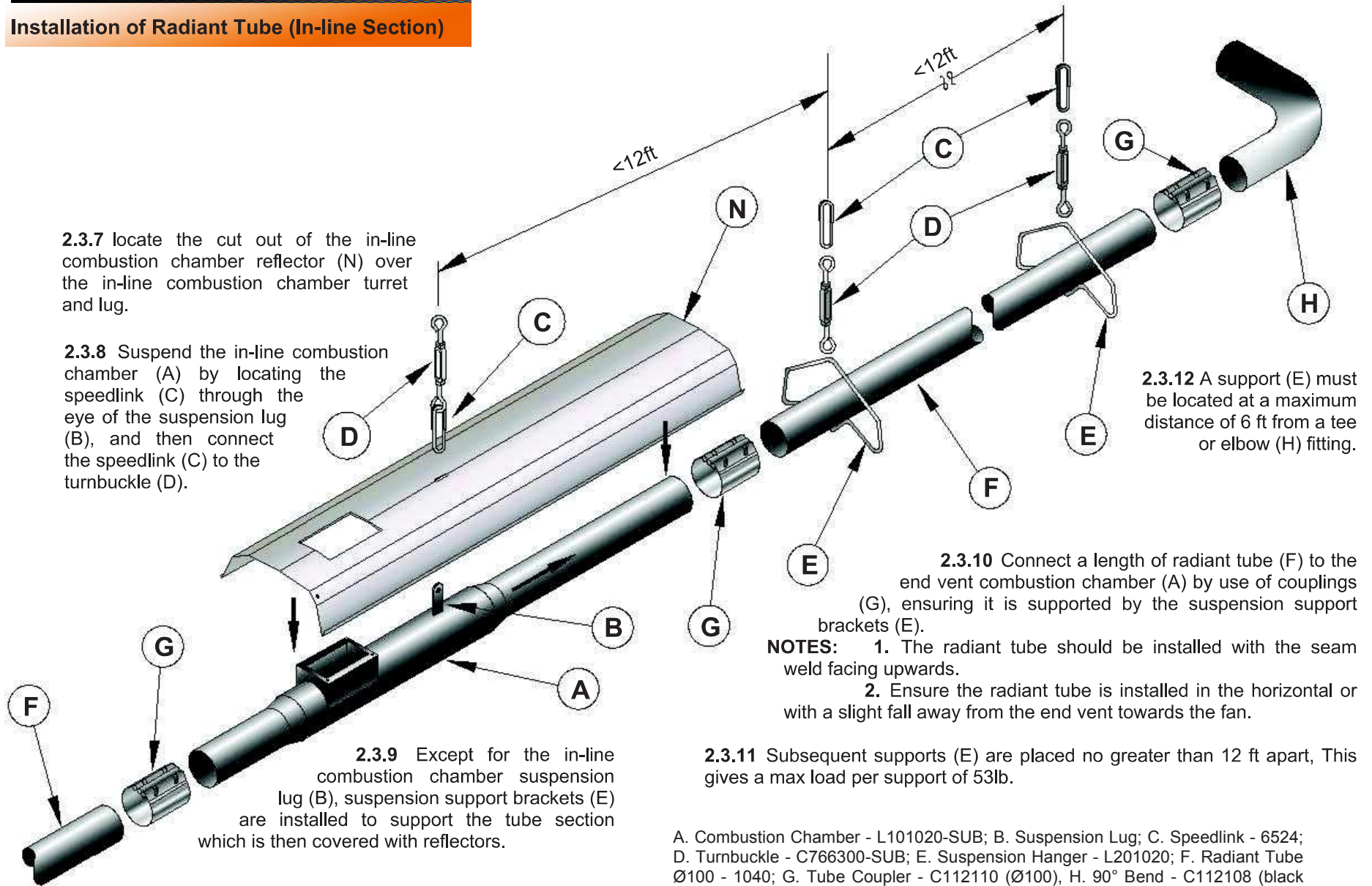
**NOTES:** 1. The radiant tube should be installed with the seam weld facing upwards.  
 2. Ensure the radiant tube is installed in the horizontal or with a slight fall away from the end vent towards the fan.

Suspension Hanger (E) maybe different to that shown.

A. Combustion Chamber - L101020-SUB; B. Suspension Lug; C. Speedlink - 6524; D. Turnbuckle - C766300-SUB; E. Suspension Hanger - L201020; F. Radiant Tube Ø100 - 1040; G. Tube Coupler - C112110 (Ø100); N. Combustion Chamber Reflector - L105060 (Aluminum).

## Installation of Radiant Tube (In-line Section)

39



**2.3.7** locate the cut out of the in-line combustion chamber reflector (N) over the in-line combustion chamber turret and lug.

**2.3.8** Suspend the in-line combustion chamber (A) by locating the speedlink (C) through the eye of the suspension lug (B), and then connect the speedlink (C) to the turnbuckle (D).

**2.3.9** Except for the in-line combustion chamber suspension lug (B), suspension support brackets (E) are installed to support the tube section which is then covered with reflectors.

**2.3.12** A support (E) must be located at a maximum distance of 6 ft from a tee or elbow (H) fitting.

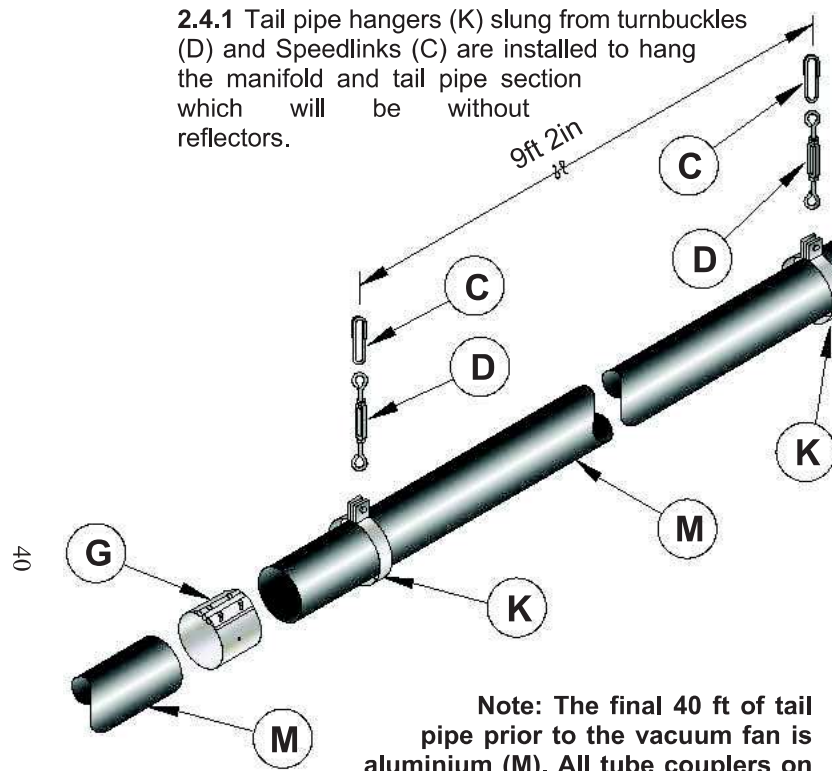
**2.3.10** Connect a length of radiant tube (F) to the end vent combustion chamber (A) by use of couplings (G), ensuring it is supported by the suspension support brackets (E).

**NOTES:** 1. The radiant tube should be installed with the seam weld facing upwards.  
2. Ensure the radiant tube is installed in the horizontal or with a slight fall away from the end vent towards the fan.

**2.3.11** Subsequent supports (E) are placed no greater than 12 ft apart, This gives a max load per support of 53lb.

A. Combustion Chamber - L101020-SUB; B. Suspension Lug; C. Speedlink - 6524; D. Turnbuckle - C766300-SUB; E. Suspension Hanger - L201020; F. Radiant Tube Ø100 - 1040; G. Tube Coupler - C112110 (Ø100), H. 90° Bend - C112108 (black Ø100); N. Combustion Chamber Reflector - L105060 (Aluminum).

Suspension Hanger (E) maybe different to that shown.

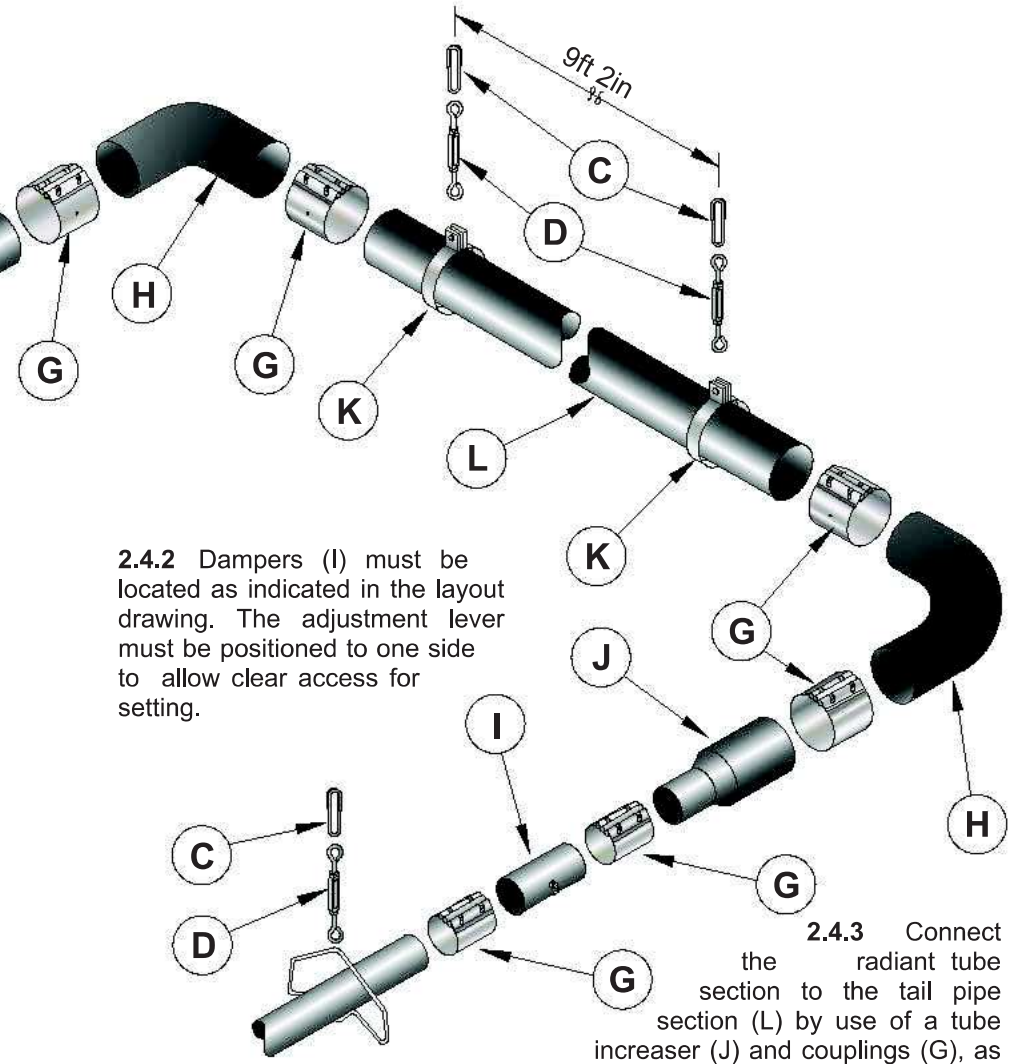


2.4.1 Tail pipe hangers (K) slung from turnbuckles (D) and Speedlinks (C) are installed to hang the manifold and tail pipe section which will be without reflectors.

Note: The final 40 ft of tail pipe prior to the vacuum fan is aluminium (M). All tube couplers on this section ONLY must be sealed with a bead of silicone sealant on each side of the coupler.

**NO SEALANT ON ANY BLACK TUBE!!**

Note: Ensure the tail pipe section has the correct fall (1 inch in every 20 ft towards the fan).



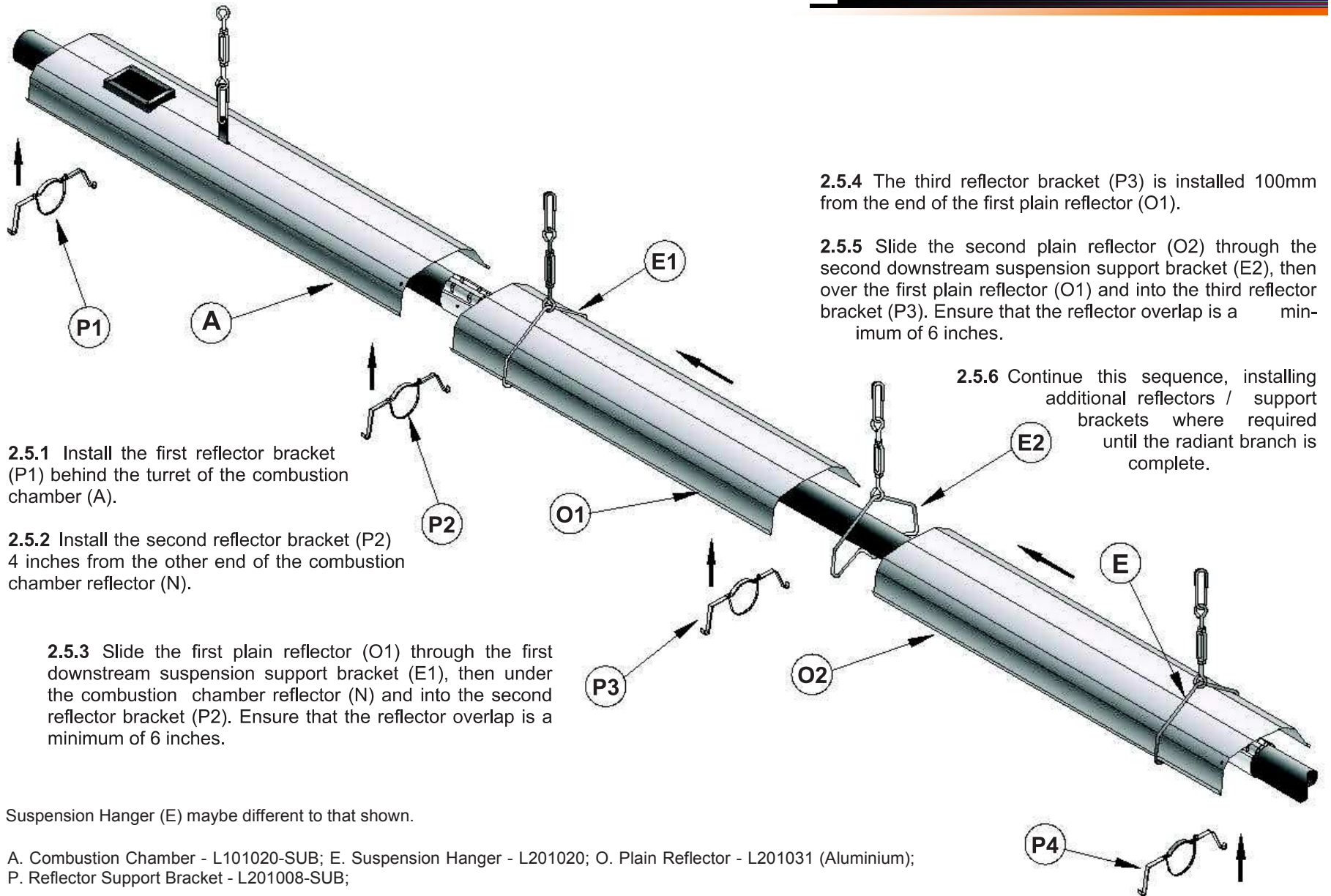
2.4.2 Dampers (I) must be located as indicated in the layout drawing. The adjustment lever must be positioned to one side to allow clear access for setting.

2.4.3 Connect the radiant tube section to the tail pipe section (L) by use of a tube increaser (J) and couplings (G), as per the layout drawing.

- C. Speedlink - 6524; D. Turnbuckle - C766300-SUB; E. Suspension Hanger - L201020; G. Tube Coupler - C112110 (Ø100), C112120 (Ø150); H. 90° Bend - C112108 (black Ø100), C112109 (black Ø150), L101554 (Alum Ø150); I. Damper - C110241-SUB; J. Increaser - C112117; K. Ø150 Tail Pipe Hanger - C112015; L. Ø150 Black Tail Pipe - C112126; M. Ø150 Alum Tail Pipe - 7230-3.



41



**2.5.1** Install the first reflector bracket (P1) behind the turret of the combustion chamber (A).

**2.5.2** Install the second reflector bracket (P2) 4 inches from the other end of the combustion chamber reflector (N).

**2.5.3** Slide the first plain reflector (O1) through the first downstream suspension support bracket (E1), then under the combustion chamber reflector (N) and into the second reflector bracket (P2). Ensure that the reflector overlap is a minimum of 6 inches.

**2.5.4** The third reflector bracket (P3) is installed 100mm from the end of the first plain reflector (O1).

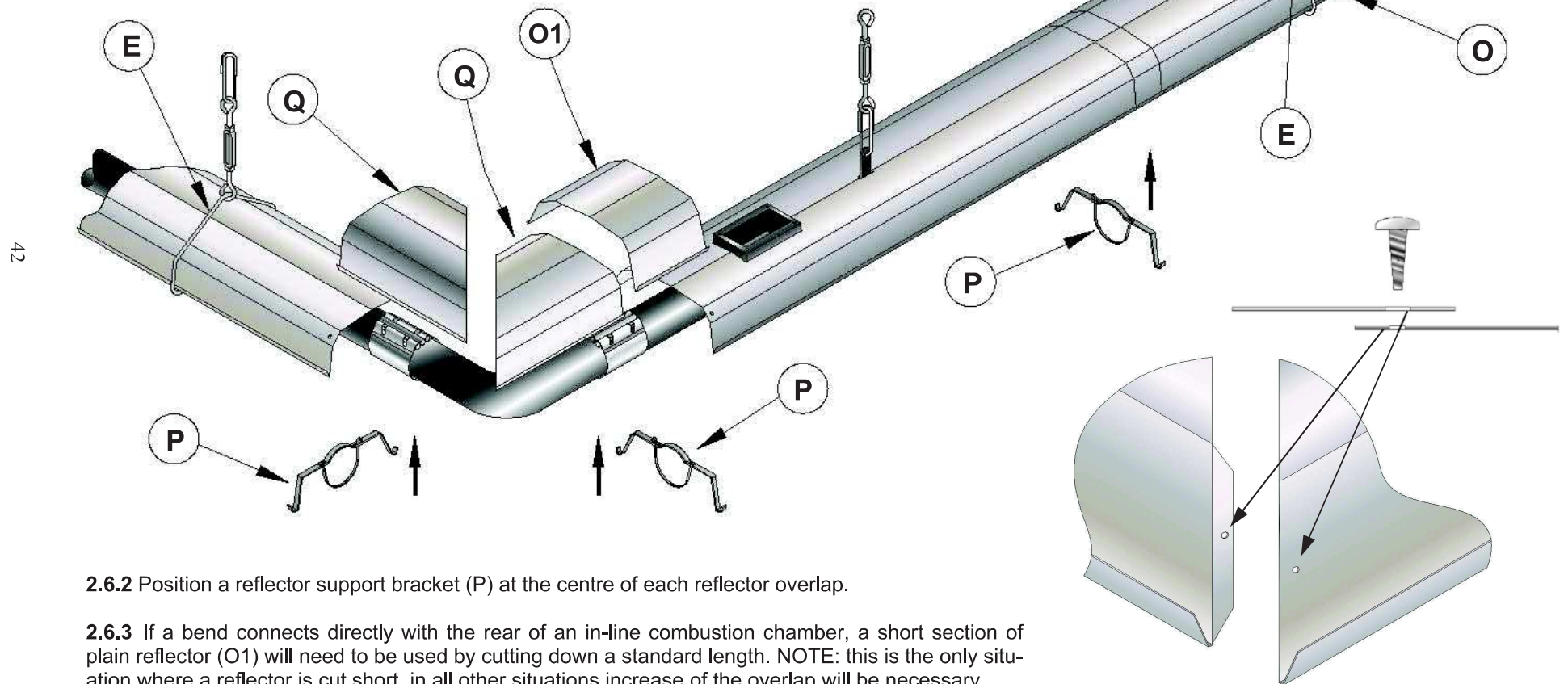
**2.5.5** Slide the second plain reflector (O2) through the second downstream suspension support bracket (E2), then over the first plain reflector (O1) and into the third reflector bracket (P3). Ensure that the reflector overlap is a minimum of 6 inches.

**2.5.6** Continue this sequence, installing additional reflectors / support brackets where required until the radiant branch is complete.

Suspension Hanger (E) maybe different to that shown.

A. Combustion Chamber - L101020-SUB; E. Suspension Hanger - L201020; O. Plain Reflector - L201031 (Aluminium); P. Reflector Support Bracket - L201008-SUB;

**2.6.1** The corner section must first be assembled by overlapping the right hand reflector (Q1) over the tabbed left hand reflector (Q2) and secured using a No. 8 self tapping screws into a capture nut placed on the flange of the reflector (Q2). nb Ensure that the two reflector overlaps are 6 inches.

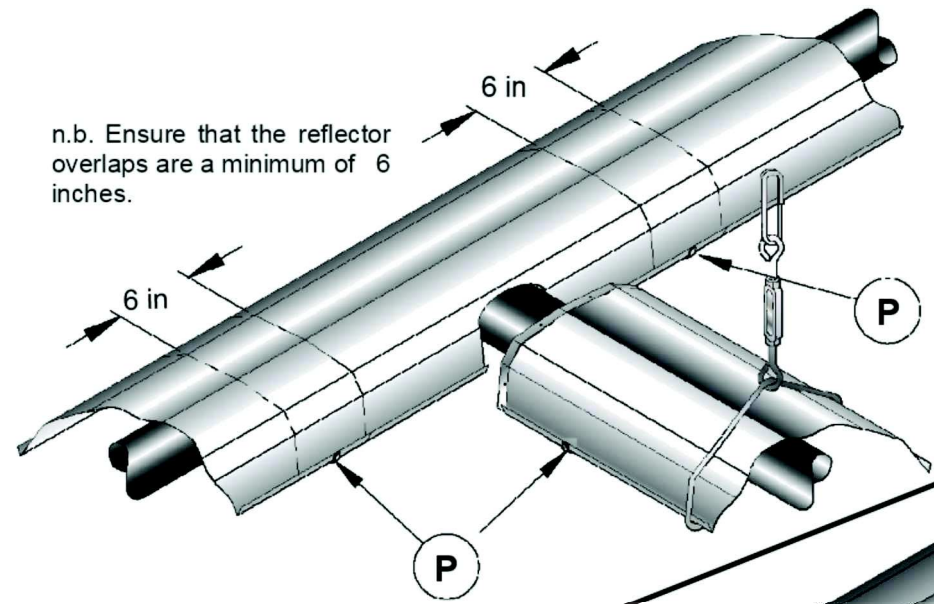


**2.6.2** Position a reflector support bracket (P) at the centre of each reflector overlap.

**2.6.3** If a bend connects directly with the rear of an in-line combustion chamber, a short section of plain reflector (O1) will need to be used by cutting down a standard length. NOTE: this is the only situation where a reflector is cut short, in all other situations increase of the overlap will be necessary.

A. Combustion Chamber - L101020-SUB; E. Suspension Hanger - L201020; O. Plain Reflector - L201031 (Aluminium); P. Reflector Support Bracket - L201008-SUB; Q. Corner Reflector Assembly - L105039-SUB (Aluminium).

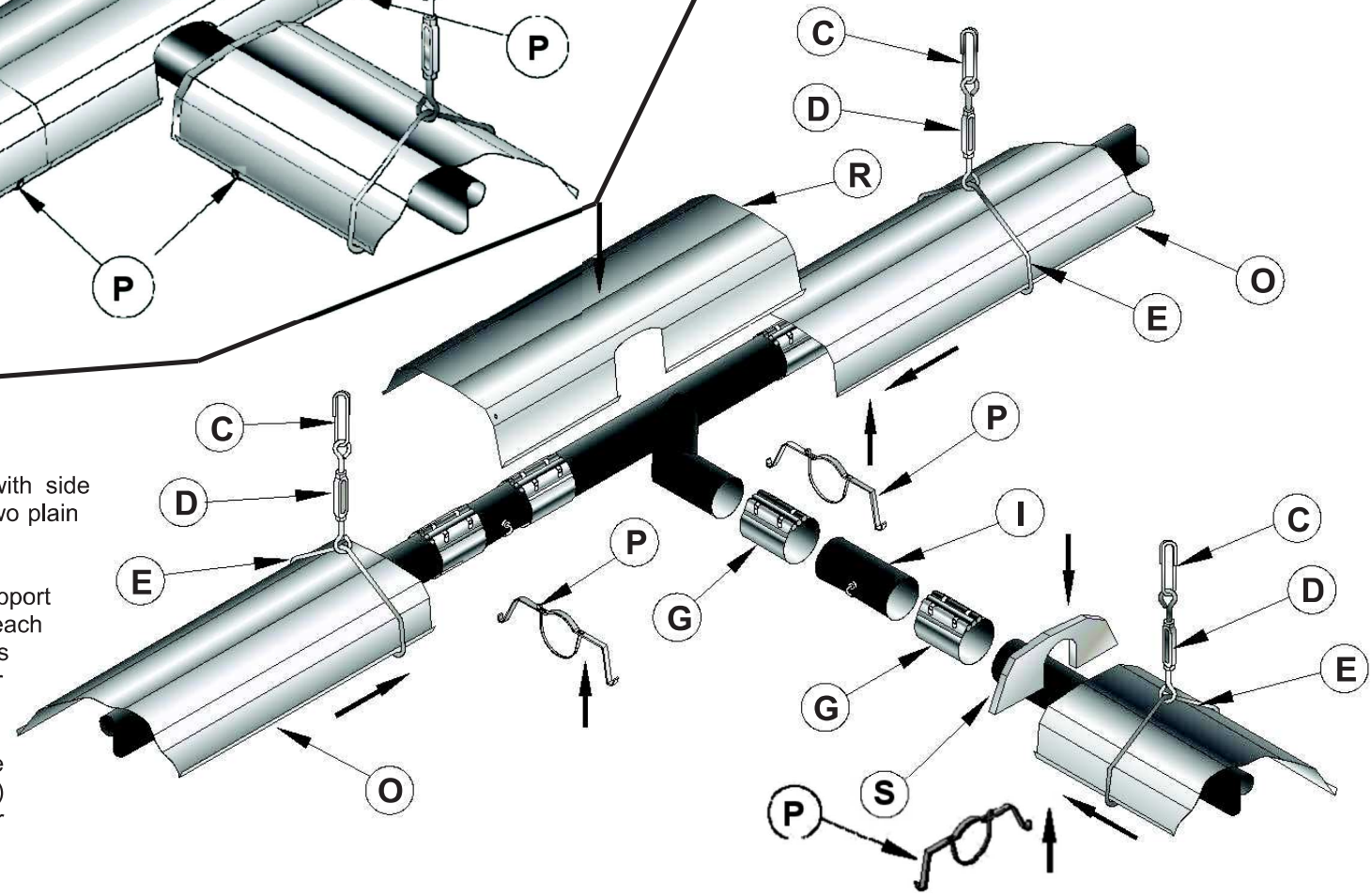
n.b. Ensure that the reflector overlaps are a minimum of 6 inches.



2.7.1 Position the reflector with side cut-out over the ends of the two plain reflectors.

2.7.2 Position a reflector support bracket (P) at the centre of each reflector overlap and 4 inches from end of last plain reflector in radiant branch.

2.7.3 At the entry to the tee section, the plain reflector (O) MUST be fitted with a reflector end cap (S).



- C. Speedlink - 6524; D. Turnbuckle - C766300-SUB; E. Suspension Hanger - L201020; G. Tube Coupler - C112110 (Ø100), C112120 (Ø150); I. Damper - C110241-SUB; O. Plain Reflector - L201031 (Aluminium); P. Reflector Support Bracket - L201008-SUB; R. Reflector with Side cut out - L105035 (Aluminium); S. End Cap - L105041 (Aluminium);

**2.8.1 General.** Ensure all reflector overlaps are a minimum of 6 inches and that there is a reflector support bracket positioned in the centre of the overlap.

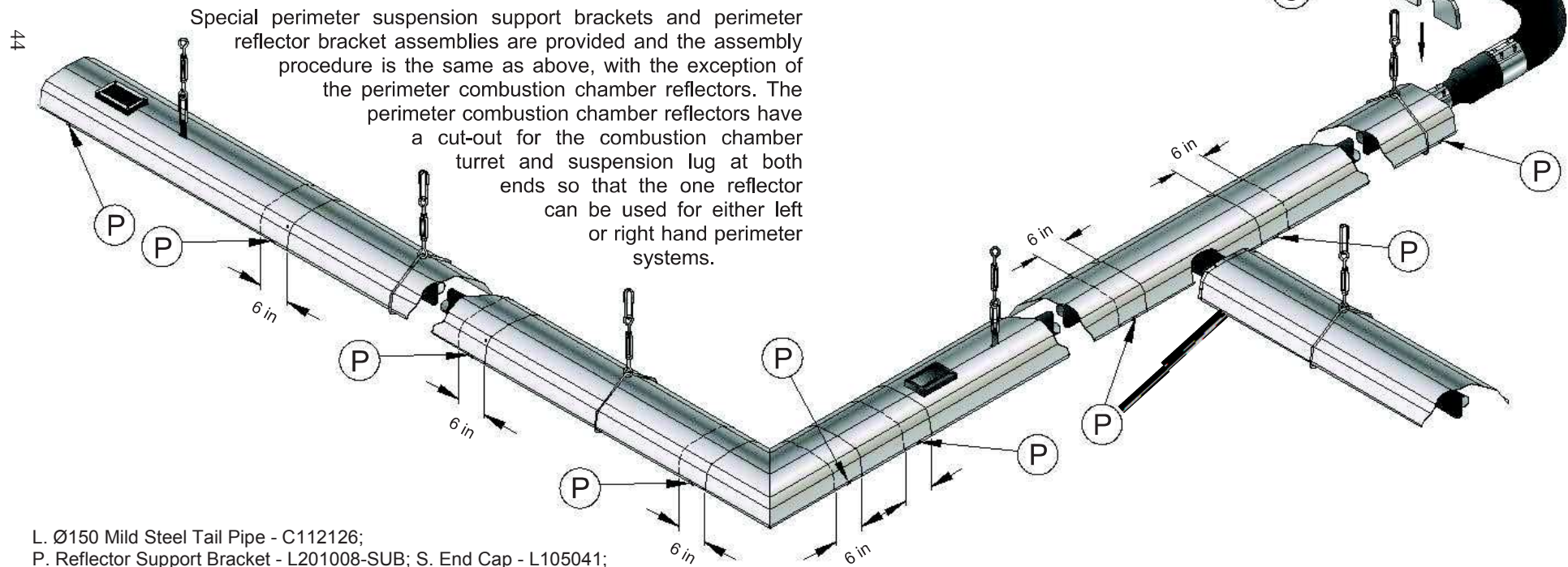
**2.8.2 End Caps.** At the end of each reflected radiant branch the last reflector must have an end cap (S) fitted.

2.8.2.1 Using the end cap (S) as a template mark the positions of the two fixing holes onto the last reflector. Drill two 7/32" diameter holes through the positions marked.

2.8.2.2 Position the end cap (S) under the last reflector and secure using the two M4 set-screws provided.

**2.8.3 Perimeter reflectors** (Not shown) Perimeter reflectors are used when the radiant tube is mounted at the perimeter of the building. They are standard 7ft 10in long reflectors but with one side extended to direct the radiant heat away from the wall.

Thus, the overlap of the perimeter combustion chamber reflector with the second perimeter reflector must be such that the cut-outs are adequately covered i.e. **3ft 3in overlap**.



C. Speedlink - 6524; D. Turnbuckle - C766300-SUB; E. Suspension Hanger - C110500-SUB; G. Tube Coupler - C112120 (Ø150); M. Ø150 Alum Tail Pipe - 7230-3; T. Expansion Joint - 7532; U. Jubilee Clip Ø150 - 7542; V. Condensate Trap Assembly - L101527-SUB; W. Tee Piece Ø150 - M201024; Y. Fan - refer table.9; Za. Ø150 Flue Pipe (1m lengths) - A791050; Zb. Flue Terminal - L101580-SUB

The vacuum fan (Y) must be located as shown in the layout drawing and must have a bottom horizontal discharge.

**2.9.1 Fan exhaust duct for vertical discharge.**

2.9.1.1 In vertical discharge, a tee piece (W) must be fitted in the exhaust ducting with a connection to drain.

Flue couplers (G) are used to connect all exhaust flue fittings.

All ducting must be sealed using silicone sealant to avoid condensate leaking to the outside of the ductwork.

Ensure that an adequate weatherproof seal such as a 'dekitite' is made where the duct passes through the roof.

The flue terminal (Zb) is fitted by first applying silicone sealant around the connecting tube ends and then inserting the swaged end of the flue terminal into the flue duct. The joint is secured by drilling through the tube and connector with 3 pop rivets at 12, 4 and 8

o'clock position. 3.5 mm (3/16 in) diameter pop rivets are recommended. (Not supplied by AmbiRad).

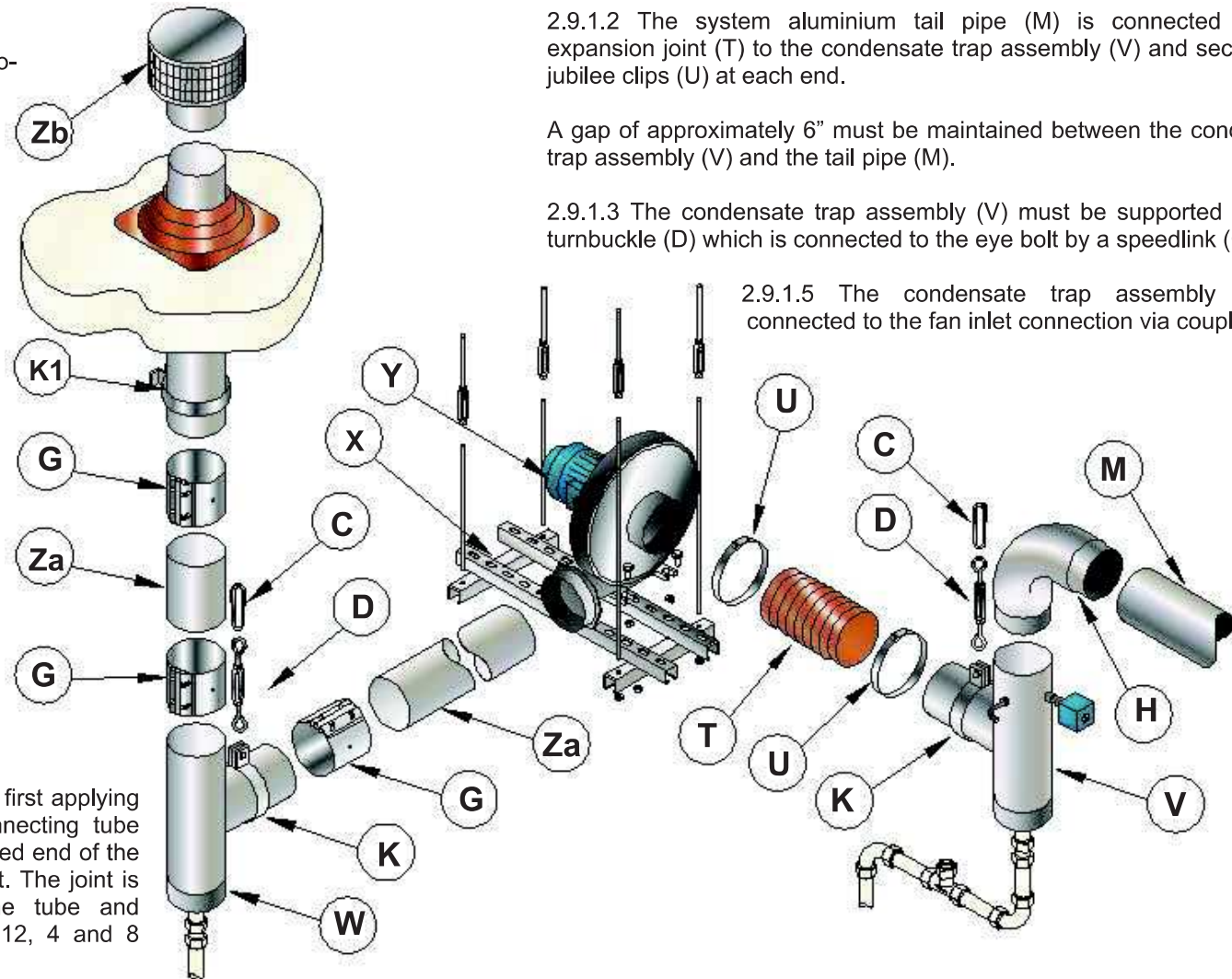
2.9.1.2 The system aluminium tail pipe (M) is connected via an expansion joint (T) to the condensate trap assembly (V) and secured by jubilee clips (U) at each end.

A gap of approximately 6" must be maintained between the condensate trap assembly (V) and the tail pipe (M).

2.9.1.3 The condensate trap assembly (V) must be supported using a turnbuckle (D) which is connected to the eye bolt by a speedlink (C).

2.9.1.5 The condensate trap assembly (V) is connected to the fan inlet connection via coupler (G).

45



C. Speedlink - 6524; D. Turnbuckle - C766300-SUB; E. Suspension Hanger - C110500-SUB; G. Tube Coupler - C112120 (Ø150); M. Ø150 Alum Tail Pipe - 7230-3; T. Expansion Joint - 7532; U. Jubilee Clip Ø150 - 7542; V. Condensate Trap Assembly - L101527-SUB; Xa. Fan Wall Mounting Platform - L103060; Xb. (alternate) Fan Base Frame; Y. Fan - refer table.9; Za. Ø150 Flue Pipe (1m lengths) - A791050; Zb. Flue Terminal - L101580-SUB

The vacuum fan (Y) must be located as shown in the layout drawing and must have a bottom horizontal discharge.

### 2.9.2 Fan exhaust duct for horizontal discharge

2.9.2.1 The exhaust flue duct (Za) must incline downwards away from the fan to avoid condensate running back into the fan. Flue couplers (G) are used to connect all exhaust duct fittings.

All flue ducting must be sealed using silicone sealant to avoid condensate leaking to the outside of the ductwork. A non-combustible sleeve (a) - not supplied by AmbiRad) must be fitted between the exhaust flue duct and the building wall.

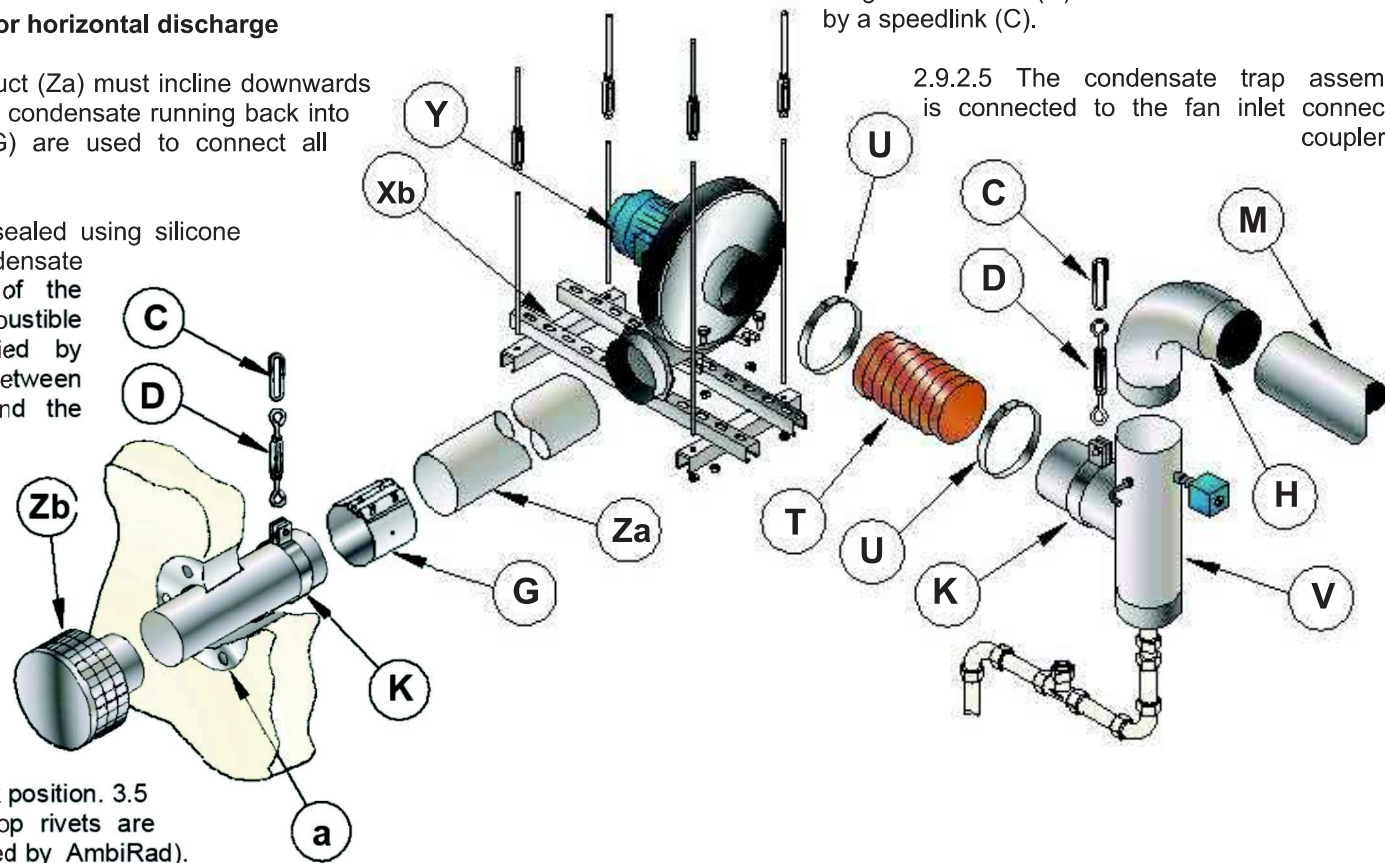
The flue terminal (Zb) is fitted by first applying silicone sealant around the connecting tube ends and then inserting the swaged end of the flue terminal into the flue duct. The joint is secured by drilling through the tube and connector with 3 pop rivets at 12, 4 and 8 o'clock position. 3.5 mm (3/16 in) diameter pop rivets are recommended. (Not supplied by AmbiRad).

2.9.2.2 The system aluminium tail pipe (M) is connected via an expansion joint (T) to the condensate trap assembly (V) and secured by jubilee clips (U) at each end.

A gap of approximately 6" must be maintained between the condensate trap assembly (V) and the tail pipe (M).

2.9.2.3 The condensate trap assembly (V) must be supported using a turnbuckle (D) which is connected to the eye bolt of a speedlink (C).

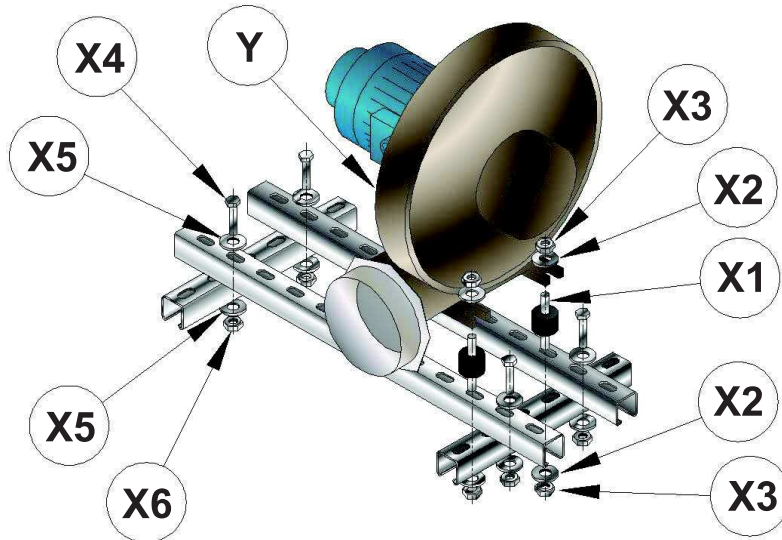
2.9.2.5 The condensate trap assembly (V) is connected to the fan inlet connection via coupler (G).



### 2.9.3 Fan Mounting

2.9.3.1 The vacuum fan must be located as shown in the layout drawing and must have a bottom horizontal discharge.

The fan (Y) should be fitted to a base frame which is fixed to the wall or building structure.



Identify the anti-vibration mounts (X1) and fixings (X2 & X3). Place An anti-vibration mount through one of the slots in the fan feet. Place washer and secure with nut as shown. Repeat for remaining vibration mounts.

Place the longer lengths of unistrut as shown over the bottom of the anti-vibration mounts as shown. Place washer and secure with nut. Repeat for remaining anti-vibration mounts.

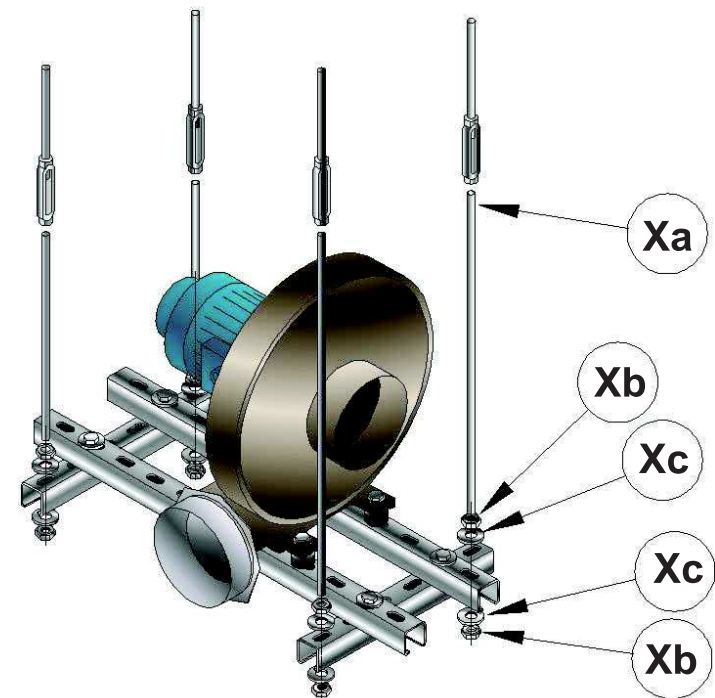
Locate the shorter pieces of unistrut and the fixings (X4-X6) provided. The fixings should contain 4 M12 x 70mm bolts (X4), 4 M12 nyloc nuts (X6) and 8 M12 washers (X5)

Xa. Fan Wall Mounting Platform - L103060; Xb. (alternate) Fan Base Frame; X1-5 Anti-vibration Mount Kit - L103045-SUB; Y. Fan - refer table.9;

Place the shorter unistrut lengths underneath, and at right angles to, the two longer lengths. The bolt (X4) and washer (X5) should be located through one of the holes and facing downwards. Position bolt through hole in shorter length and secure with washer and nyloc nuts. Repeat for remaining bolts.

**! Be sure to tighten the nut and bolt!**

2.9.3.2 The fan base frame (Xa) can be suspended from a roof structure, via drop (not supplied).



### 2.9.4 Condensate Trap Assembly

The condensate trap assembly (V) is connected to the 6 inch diameter fan inlet connection via a coupler.

Ensure that a 1½ in drain tube assembly is fitted to the connection (V1) and to the non-return valve (V3) via bends (V2).

Ensure that the non-return valve (V3 - supplied) is fitted with the flow indication arrow pointing AWAY from the trap, in the HORIZONTAL position and at a vertical distance of 26" \* for F300 fans or 20" \* for F100 & f200 fans, below the condensate trap assembly.

The condensate drainage pipe (V4 - not supplied) should be run in a standard drain pipe material, e.g. polyvinyl chloride (PVC), unplasticized polyvinyl chloride (PVC-U), acrylonitrile-butadiene-styrene (ABS), polypropylene polyproene (PP) or cross-linked polyvinyl chloride (PVC-C)

Copper or copper based alloy shall not be used for condensate drains.

The drain tube must be resistant against the action of flue gas condensate and suitable for operation up to a maximum temperature of 120°F.

Ensure that the drain tube is adequately supported.

All connecting drainage pipework should have a fall of at least 2.5° to the horizontal or approximately 2 inches per 3 foot of pipe run.

If the drainage pipe has a run externally, it is recommended that the pipe is insulated to protect against frost.

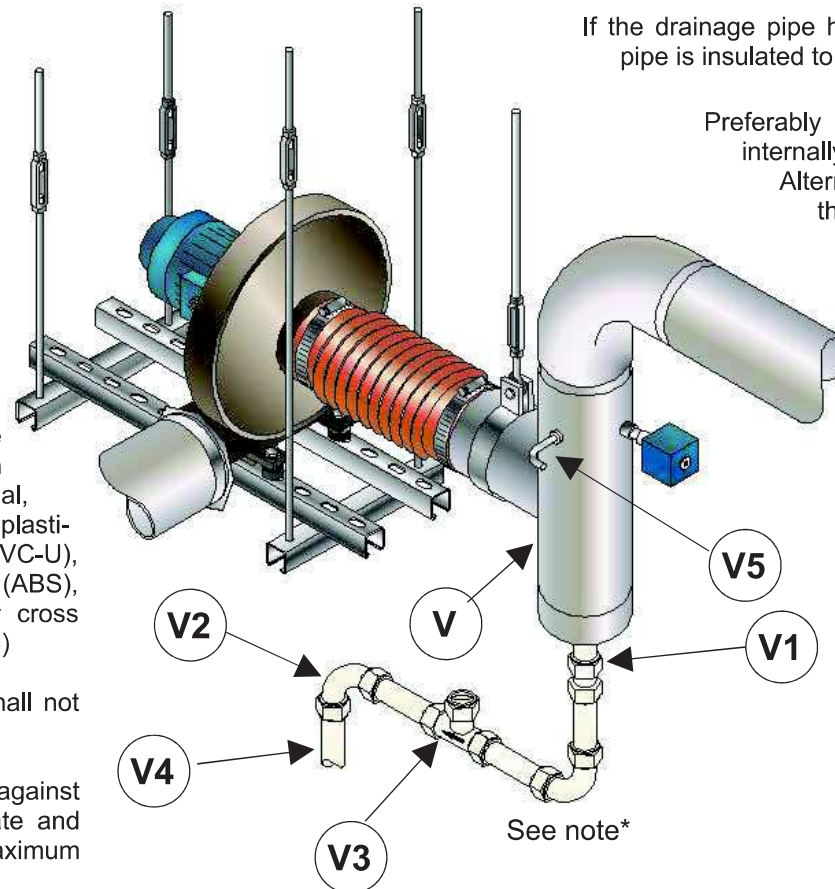
Preferably the condensate pipe should run and terminate internally to a soil and vent stack or a waste pipe. Alternatively, the condensate can be discharged into the rainwater system or a purpose-made soakway.

It should be noted that the connection of a condensate pipe to a drain might be subject to local building controls.

Any internal pipework should be of a diameter stated.

Any external pipework should be kept to a minimum to avoid freezing.


Damper to control the vacuum of the system during commissioning, is adjusted by rotating adjustment handle (V5) then locking with grub screw.





### 2.9.5 Optional Modulation Damper

The modulation damper (A) is connected to the 6 inch inlet of the fan via a stainless steel coupler (K).

Before fitting the coupler, carefully loosen the two screws. Position the coupler onto the end of the modulation damper assembly ensuring that the tightening bars are positioned uppermost 



Slide the coupler (K) over the fan inlet ensuring that the rivet stop has butted up to the spigot end.

Moving between the pins, using the 1/4" allen wrench tighten both ensuring equal pressure is applied to each set pin in turn.

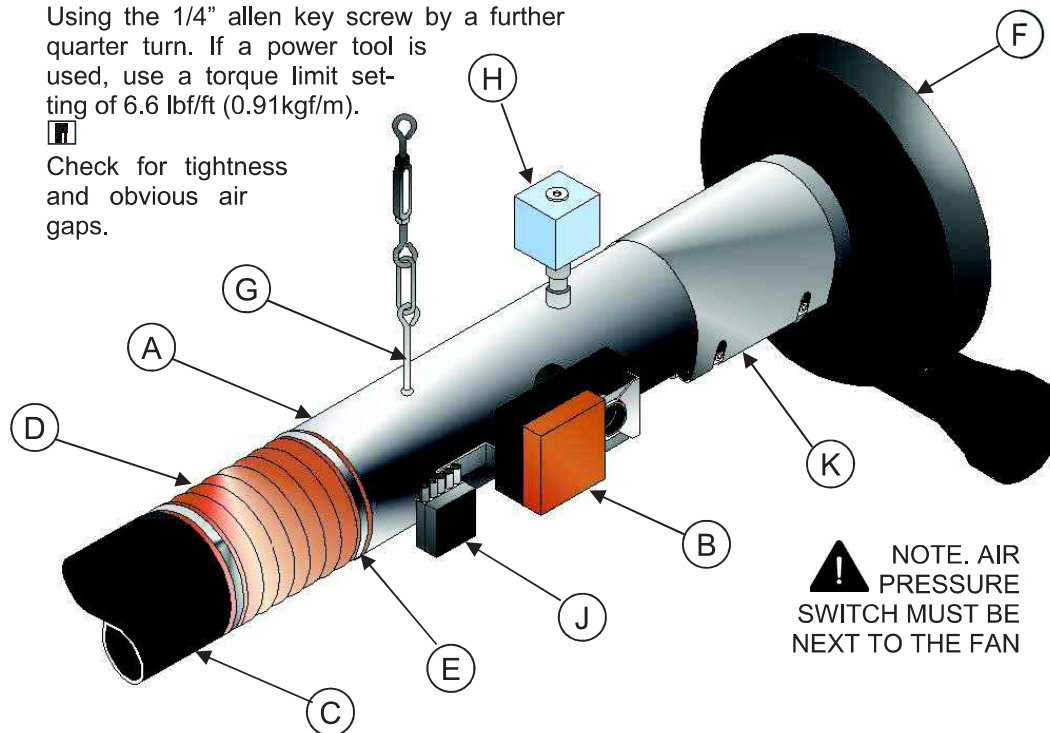
To ensure the coupler has aligned itself correctly, a slight indentation can be observed.

Using the 1/4" allen key screw by a further quarter turn. If a power tool is used, use a torque limit setting of 6.6 lbf/ft (0.91kgf/m).



Check for tightness and obvious air gaps.

49

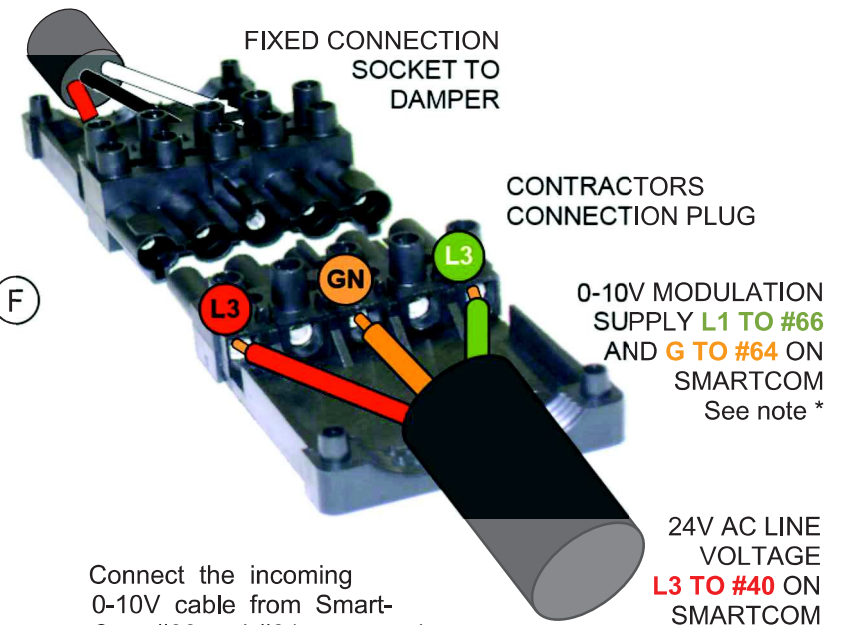


**NOTE.** AIR PRESSURE SWITCH MUST BE NEXT TO THE FAN

The fan damper is wired via a plug and socket arrangement. The socket is connected to the assembly via a bracket.

Release the loose plug and remove the cap via two screws.

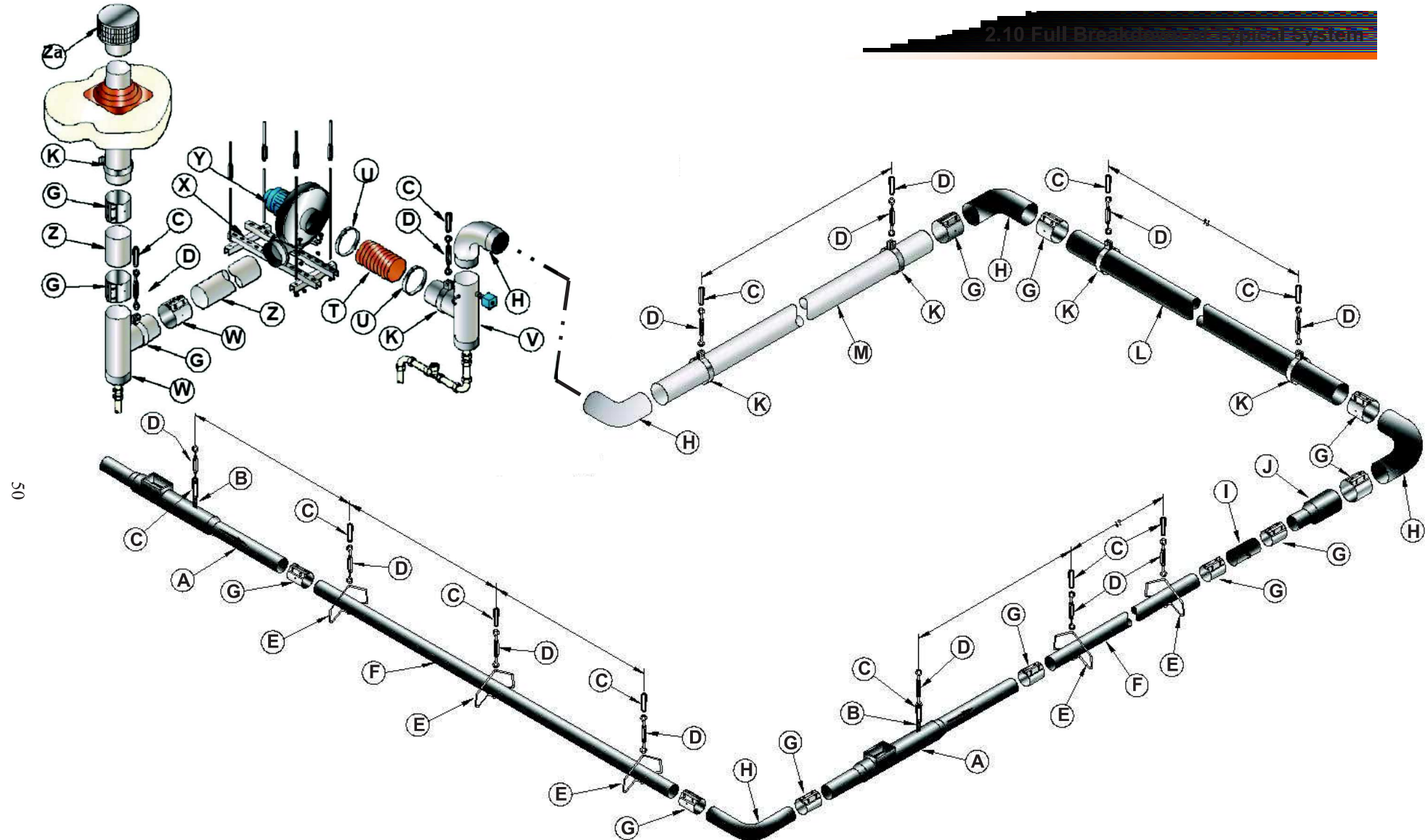
Connect the incoming 24V cable from SmartCom #40 onto terminal L3.



Connect the incoming 0-10V cable from Smart-Com #66 and #64 onto terminals L1 and GND respectively, ensuring correct orientation.

**\* IMPORTANT:**  
An additional cable is required between SmartCom #2/N and contractors plug terminal GND only if the 24VAC supply to the panel DOES NOT originate from the secondary of an isolating transformer.

Replace the cap and plug into socket.

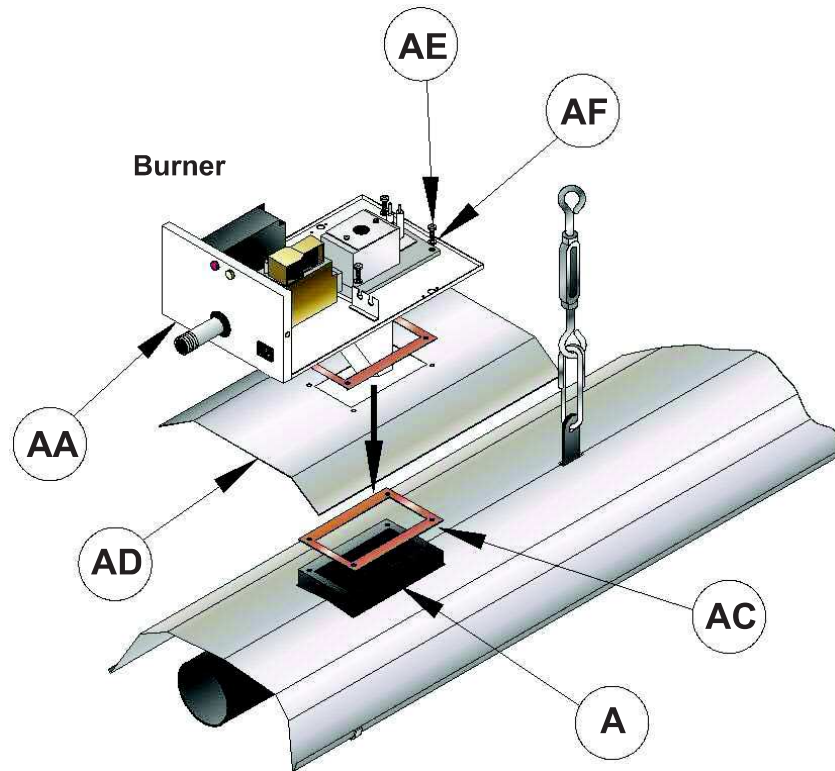


50

A. Combustion Chamber - L101020-SUB; B. Suspension Lug; C. Speedlink - 6524; D. Turnbuckle - C766300-SUB; E. Suspension Hanger - L201020; F. Radiant Tube Ø100 - 1040; G. Tube Coupler - C112110 (Ø100), C112120 (Ø150); H. 90° Bend - C112108 (black Ø100), C112109 (black Ø150), L101554 (Alum Ø150); I. Damper - C110241-SUB; J. Increaser - C112117; K. Ø150 Tail Pipe Hanger - C112015; L. Ø150 Black Tail Pipe - C112126; M. Ø150 Alum Tail Pipe - 7230-3; T. Expansion Joint - 7532; U. Jubilee Clip Ø150 - 7542; V. Condensate Trap Assembly - L101527-SUB; W. Tee Piece Ø150 - M201024; X. Fan Mounting Platform - L103060; Y. Fan - refer table.9; Za. Ø150 Flue Pipe (1m lengths) - A791050; Zb. Flue Terminal - L101580-SUB

## 2.11 Installation of End Vent 2000 BTU Burners

51



**2.11.1** Each burner is marked with its rated heat input. The correct burner **MUST** be located as indicated on the site layout drawing.

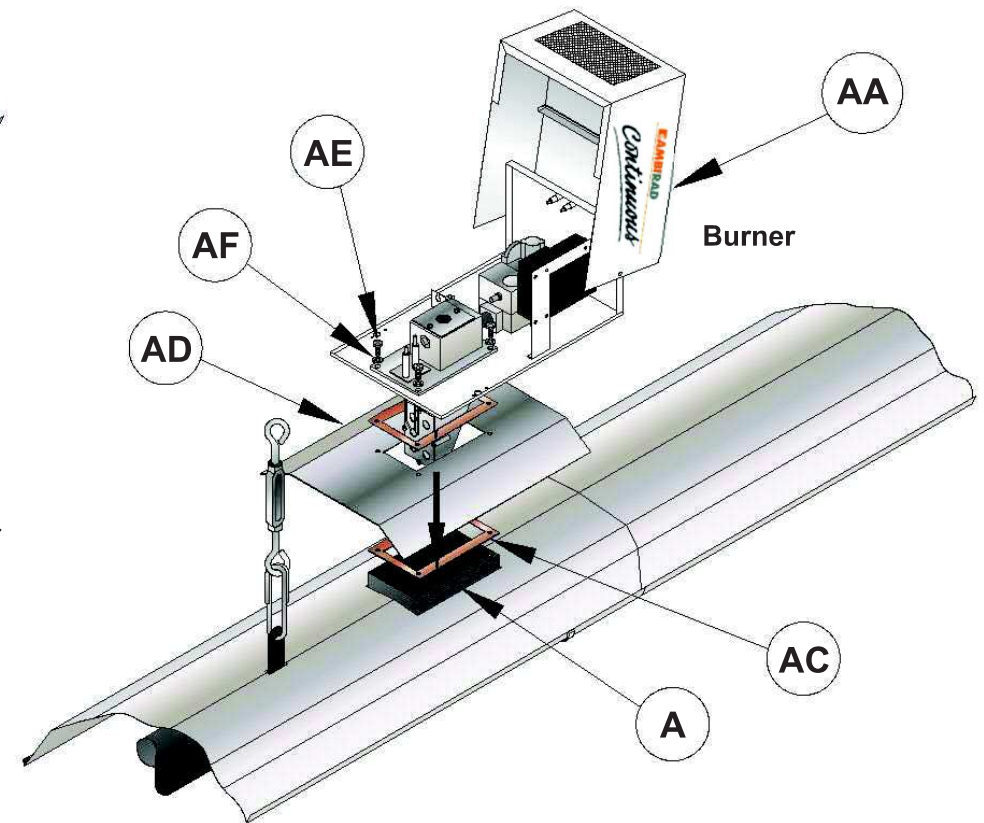
**2.11.2** Position gasket (AC) on combustion chamber turret (A), in line with all four fixing holes.

**2.11.3** Position heat shield (AD) on top of gasket (AC) in line with all four fixing holes of gasket and turret.

**2.11.4** Fit each burner through heat shield (AD), gasket (AC) and turret. Square burner in line with all four fixing holes of gasket and turret.

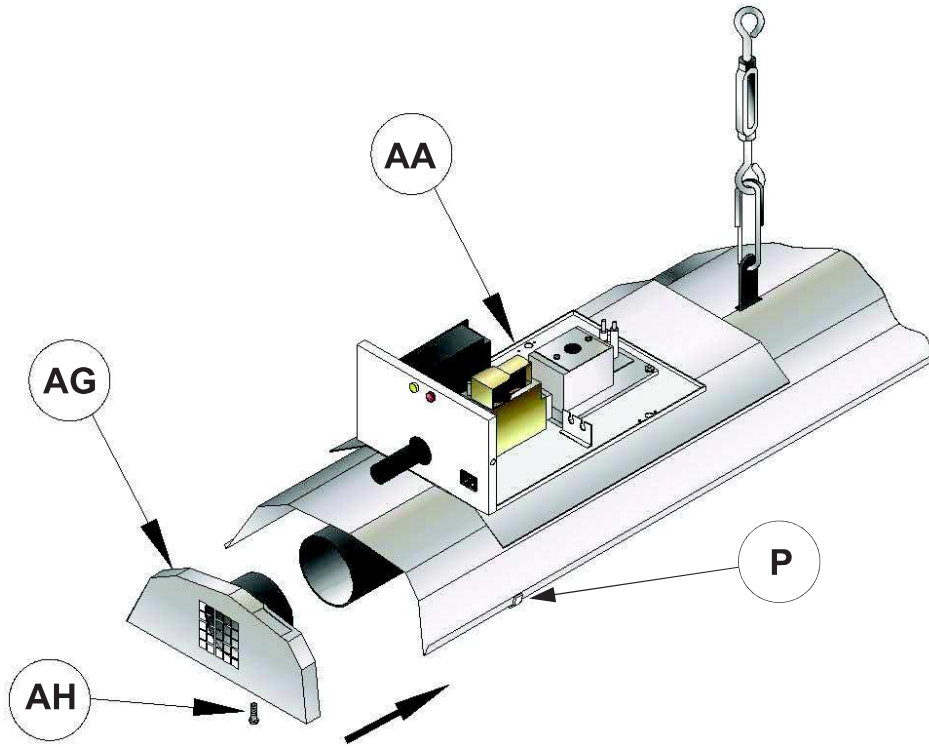
**2.11.5** Secure the burner through the heat shield (AD) and gasket (AC) to the turret using the four M6 bolts (AE) and washers (AF) provided.

**2.11.6** Repeat for all other burners



AA. Burner; AC. Burner Gasket - L102032; AD. Burner Heat Shield - 200195; AE. 6mm Set Pin - 5429-1; AF. 6mm Washer - 5425

52



**2.12.1** An end vent module or 'EVM' (AG) is positioned at each end vent burner position.

Each end vent module must be fitted with the correct end vent orifice plate to suit the end vent burner.

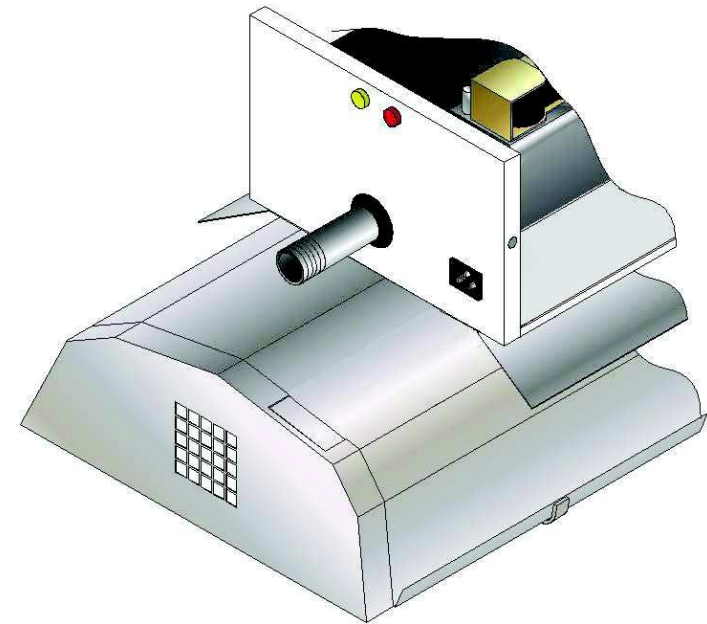
An orifice or orifice plate attached inside the EVM support spinning is located on the air entry point of the EVM.

**2.12.2** Slide the EVM support spinning over the end vent combustion chamber tube.

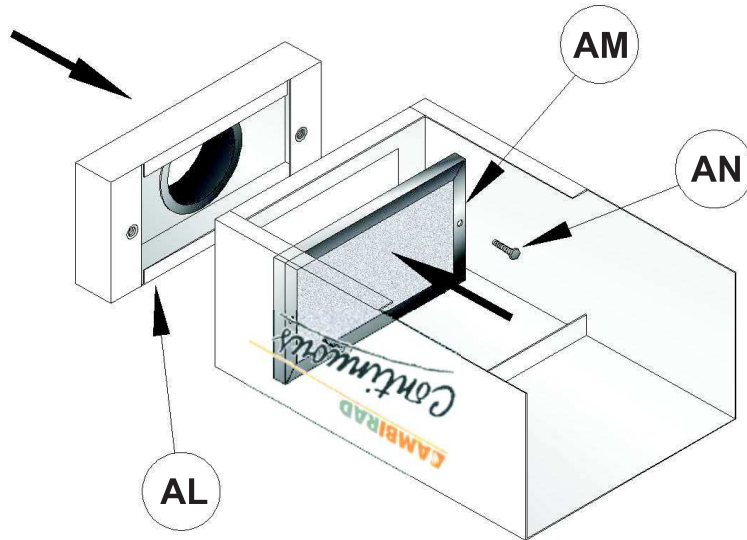
**2.12.3** Ensure combustion chamber tube end butts positively against the orifice plate.

Secure using the M8 set pin (AH).

Ensure fittings are tightened securely.



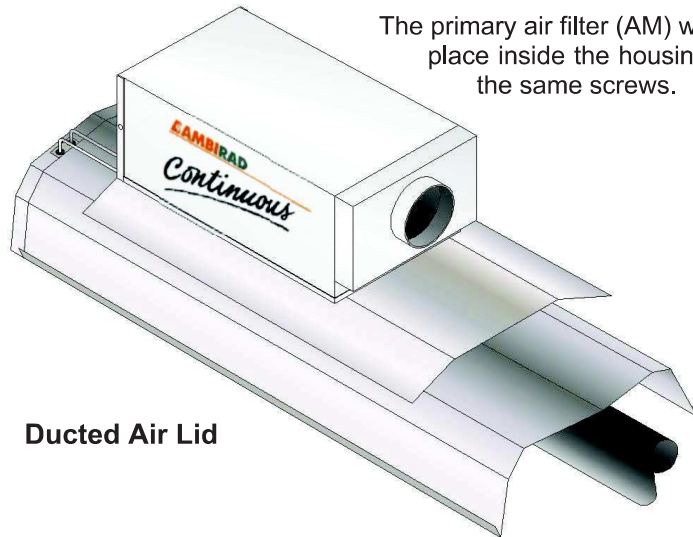
AA. End Vent Burner; AG. End Vent Module; AH. M8 Set Pin - 5447; P. Reflector Support Bracket.



**2.13.1 Fitting ducted air adaptor to burner assembly**

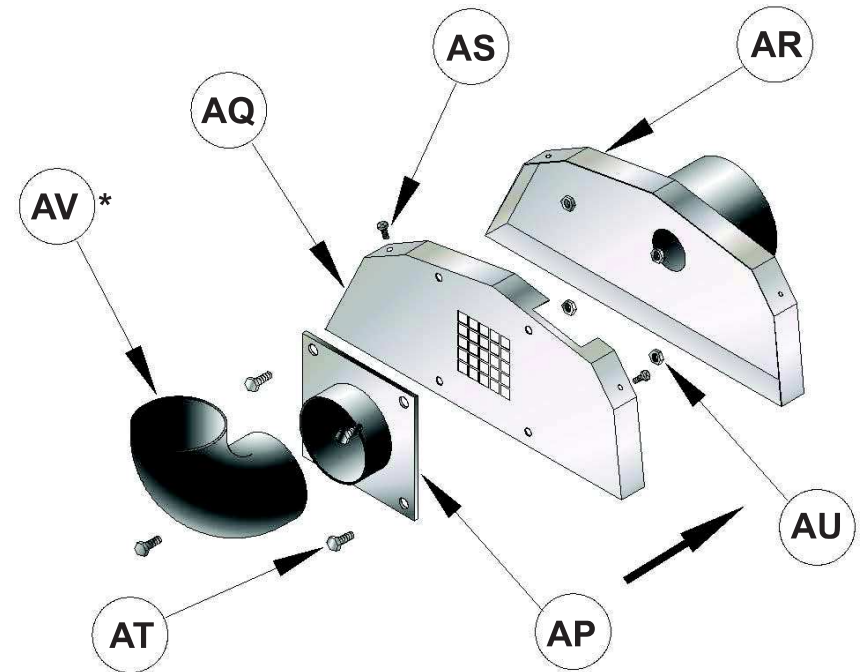
The ducted air adaptor (AL) is fitted over the air inlet position of the burner housing lid using two M5x30 set-screws (AN).

The primary air filter (AM) will remain in place inside the housing lid (A) via the same screws.



**Ducted Air Lid**

AL. Burner Ducted Air Adaptor - L104115; AM. Filter - L102013; AN. M5x30 Set screw; AP. EVM Ducted Air Adaptor - L104122-SUB; AQ. EVM Outer Plate; AR. EVM Inner Plate; AS. EVM Fastener; AT. M5 Set Pin - 5369; AU. M5 Nut - 5350; AV. 90° Elbow - 7075-2



**2.13.2 Fitting ducted air adaptor to end vent module**

The ducted air adaptor (AP) is fitted to the air inlet position of the EVM. To achieve this, the EVM has to be taken apart. Remove the EVM.

2.13.2.1 Unscrew the fasteners (AS) securing the EVM outer plate (AQ) and remove.

2.13.2.2 Position ducted air adaptor against inlet plate and secure using four M5 set pins (AT) washers and Nuts (AU) provided.

2.13.2.3 Reposition assembled plate onto the EVM inner plate (AR) and affix using screws (AS)

\* Optional 90° elbow (AV) can be fitted to allow individual orientation.

The ARC ballguard system consists of standard 8ft long modules which are supported from the underside of the radiant tube. The ballguard sections are fitted in tandem along the system. Perimeter ballguards are installed in the same manor.

**2.14.1 Installation**

2.14.1.1 Starting at each system end vent, position the 'U' bolts (BB) around the radiant tube, through the clamp bridge (BC) and secure using with M8 nuts (BE). Ensure that the distance between the 'U' bolts is approximately 3ft 8". The 'U' bolt assemblies should be positioned **perfectly square** to ensure that the ballguard module lies horizontal when fitted.

2.14.1.2 A retaining plate (BD) is positioned on the underside of the ballguard (BA) at each 'U' bolt assembly position and secured using M8 nuts (BE) and washers (BF).

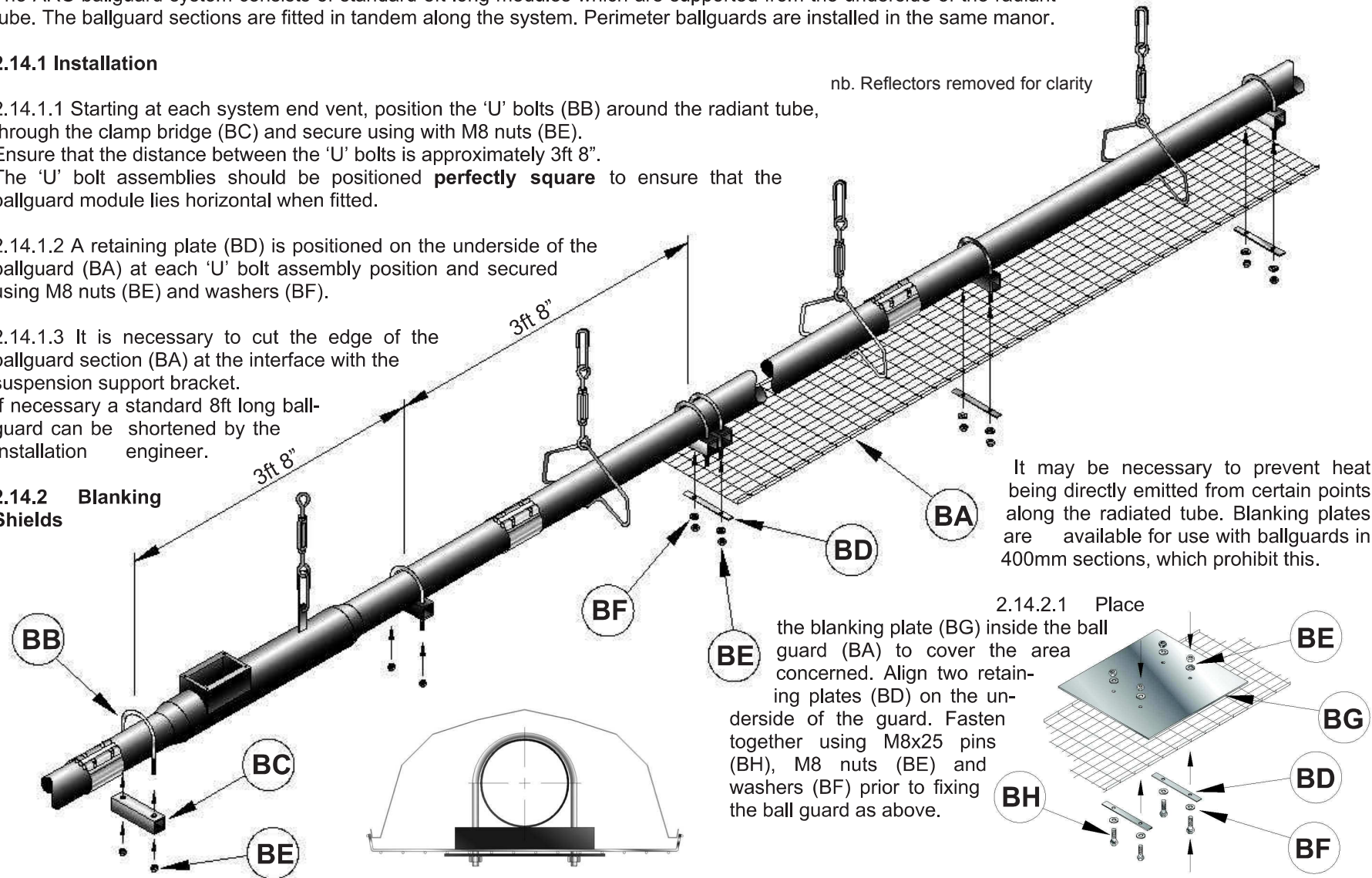
2.14.1.3 It is necessary to cut the edge of the ballguard section (BA) at the interface with the suspension support bracket. If necessary a standard 8ft long ballguard can be shortened by the Installation engineer.

**2.14.2 Blanking Shields**

It may be necessary to prevent heat being directly emitted from certain points along the radiated tube. Blanking plates are available for use with ballguards in 400mm sections, which prohibit this.

2.14.2.1 Place the blanking plate (BG) inside the ball guard (BA) to cover the area concerned. Align two retaining plates (BD) on the underside of the guard. Fasten together using M8x25 pins (BH), M8 nuts (BE) and washers (BF) prior to fixing the ball guard as above.

54



BA. 2.44M Ballguard - C110555; BB. 'U' Bolt - C110548; BC. Clamp Bridge - C110549; BD. Clamp Plate - C110449; BE. M8 Nut - 5441; BF. M8 Washer - 5445; BG. Blanking Shield - L106020; BH. M8 x 25 Set Pin

## 2.15 Installation of Slimline 'M' Decorative Grille System

The Slimline 'M' decorative grille system consists of standard 8ft long modular grille assemblies which are supported from the underside of the radiant tube. The modular assemblies are fitted in tandem along the system.

### 2.15.1 Standard 8ft long modular grille assemblies

2.15.1.1 Starting at each system end vent, position the 'U' bolts (BB) around the radiant tube, through the clamp bridge (BC) and secure using with M8 locknuts (BE) approximately 10mm from the ends of the threads.

Ensure that the distance between 'U' bolts is 4 ft. The 'U' bolt assemblies should be positioned **perfectly square** to ensure that the modular grille assembly lies horizontal when fitted.

2.15.1.2 Fit 2 eggcrate grille pieces (BL) into the standard 8ft long grille support frame (BK).

2.15.1.3 Raise the modular grille assembly (BJ) and pass the threaded ends of the three 'U' bolts through the three sets of fixing holes.

2.15.1.3 Fit the M8 dome head nuts (BM) and washers (BF) to the threaded ends of the 'U' bolts. Check that the module is secure.

A standard 2.44m long modular grille assembly can

nb. Reflectors removed for clarity

be shortened to suit the system layout and also to accommodate corner reflector sections.

### 2.15.2 Shortened modular grille assemblies.

2.15.2.1 Carefully disconnect one end support from the standard 2.44m long grille support frame (BK).

2.15.2.2 Cut the side support to the required length, ensuring that the cut ends are square and free from burrs. Reposition the end

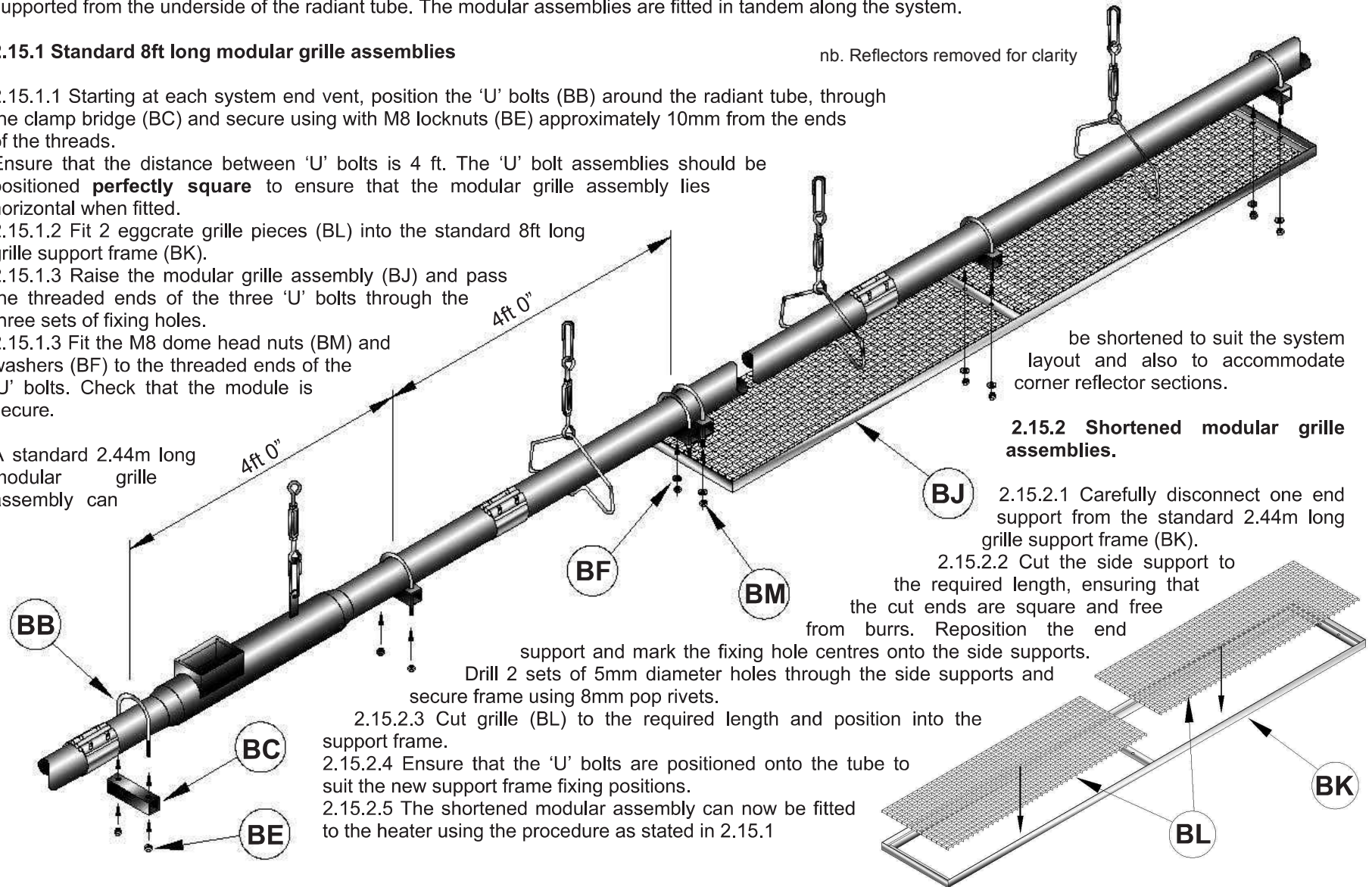
support and mark the fixing hole centres onto the side supports.

Drill 2 sets of 5mm diameter holes through the side supports and secure frame using 8mm pop rivets.

2.15.2.3 Cut grille (BL) to the required length and position into the support frame.

2.15.2.4 Ensure that the 'U' bolts are positioned onto the tube to suit the new support frame fixing positions.

2.15.2.5 The shortened modular assembly can now be fitted to the heater using the procedure as stated in 2.15.1



BB. 'U' Bolt - C110548; BC. Clamp Bridge - C110549; BE. M8 Nut - 5441; BF. M8 Washer - 5445; BJ. Modular Grille Assembly - L106000-SUB; BK. Support Frame - L106004; BL. Eggcrate Grille - L106015; BM. M8 Dome Nuts - L106007

It may be necessary to prevent heat being directly emitted from certain points along the radiated tube. Blanking plates are available in either 4ft 1" or 16" sections, which prohibit this.

**2.16.1 Installation**

2.16.1.1 Locate radiant tube area to be blanked. Position the 'U' bolts (BB) around the radiant tube, through the clamp bridge (BC) and secure using with M8 nuts (BE).

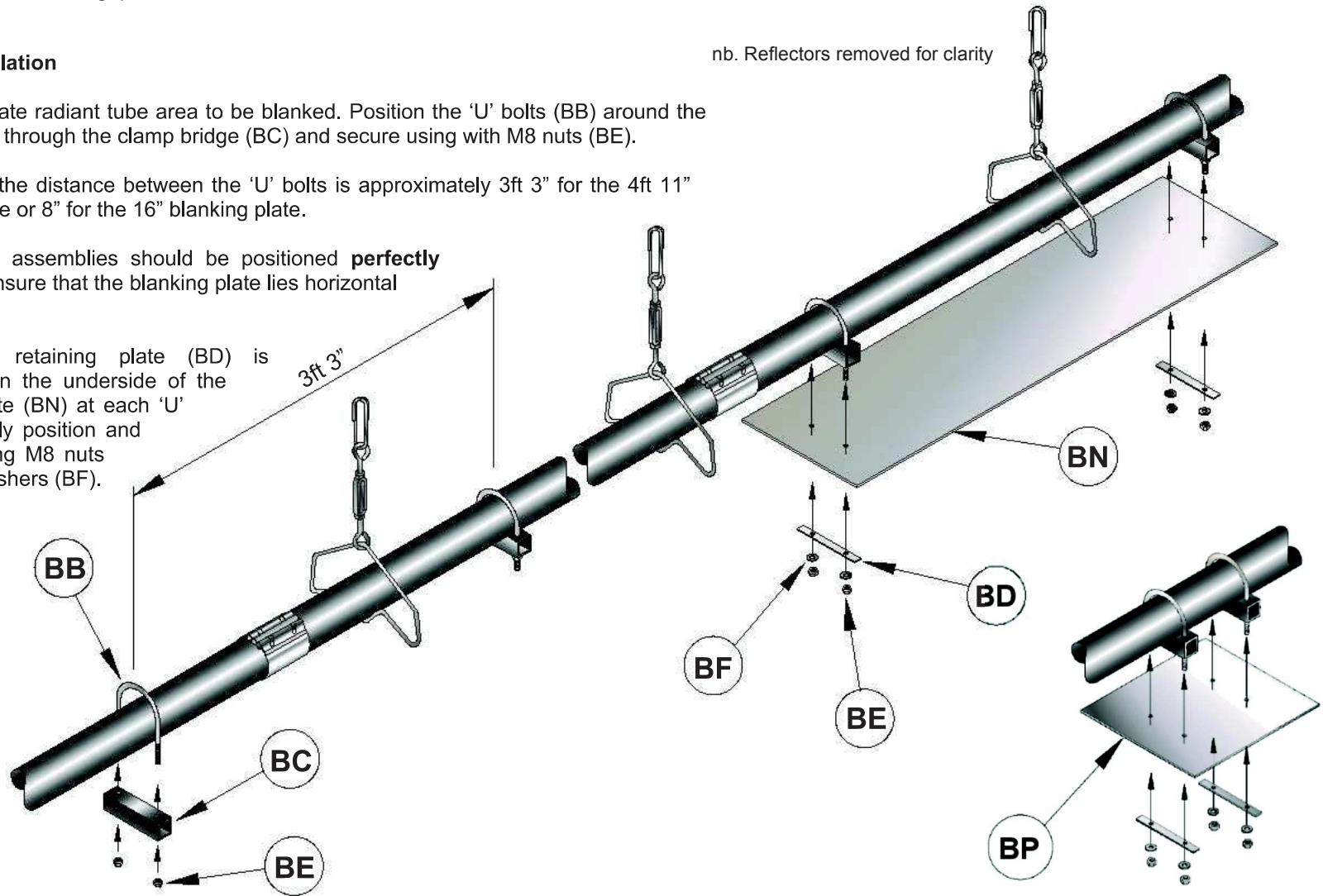
Ensure that the distance between the 'U' bolts is approximately 3ft 3" for the 4ft 11" blanking plate or 8" for the 16" blanking plate.

The 'U' bolt assemblies should be positioned **perfectly square** to ensure that the blanking plate lies horizontal when fitted.

2.16.1.2 A retaining plate (BD) is positioned on the underside of the blanking plate (BN) at each 'U' bolt assembly position and secured using M8 nuts (BE) and washers (BF).

nb. Reflectors removed for clarity

56



BB. 'U' Bolt - C110548; BC. Clamp Bridge - C110549; BD. Clamp Plate - C110449; BE. M8 Nut - 5441; BF. M8 Washer - 5445; BN. Blanking Shield 4ft 1" - L106020-1; BP. Alt Blanking Shield 16" - L106020



An Undershield Deflector (BR) is positioned beneath the radiant tube, usually at the first half of the firing leg (nearest the burner), although this can be positioned at any point if being used purely as a heat deflector for clearance purposes.

The oversized munsen rings (BQ) supplied will allow the undershield deflector to move with the expansion and contraction of the radiant tube.

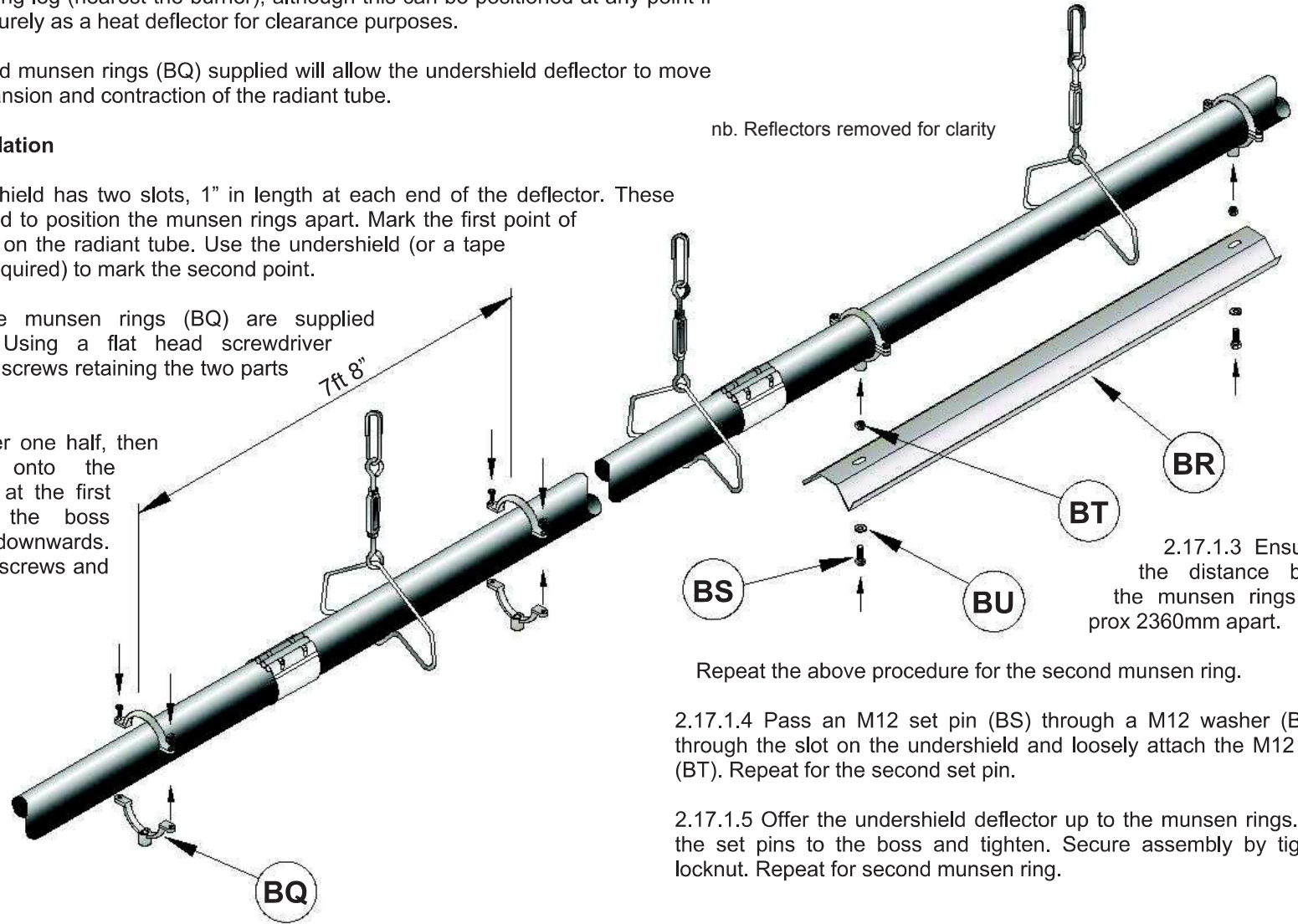
**2.17.1 Installation**

Each undershield has two slots, 1" in length at each end of the deflector. These slots are used to position the munsen rings apart. Mark the first point of the deflector on the radiant tube. Use the undershield (or a tape measure if required) to mark the second point.

2.17.1.1 The munsen rings (BQ) are supplied assembled. Using a flat head screwdriver remove both screws retaining the two parts together.

2.17.1.2 Offer one half, then the other onto the radiant tube at the first mark with the boss facing downwards. Replace the screws and tighten.

nb. Reflectors removed for clarity



2.17.1.3 Ensure that the distance between the munsen rings is approx 2360mm apart.

Repeat the above procedure for the second munsen ring.

2.17.1.4 Pass an M12 set pin (BS) through a M12 washer (BU) and through the slot on the undershield and loosely attach the M12 locknut (BT). Repeat for the second set pin.

2.17.1.5 Offer the undershield deflector up to the munsen rings. Locate the set pins to the boss and tighten. Secure assembly by tightening locknut. Repeat for second munsen ring.

57

The ARC End Vent Silencer - reduces the break out noise from the inrush of air into the combustion tube when installed within areas where noise is an issue. It is constructed of noise reducing panels assembled in an enclosure.

### 2.18.1 Assembly

2.18.1.1 Remove cover plate (AQ) of the end vent module by releasing the 2 set screws (AS).

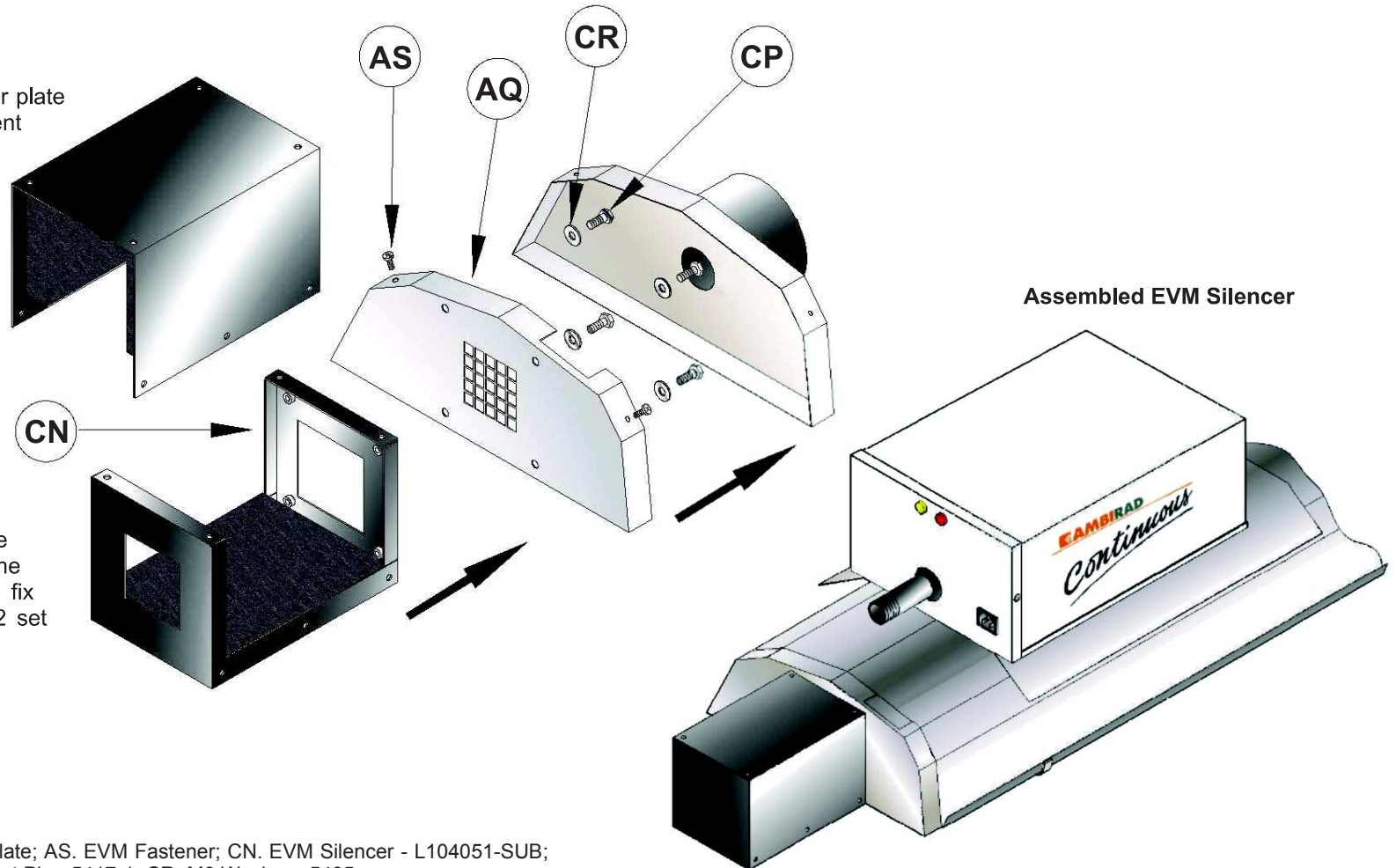
2.18.1.2 Offer the silencer (CN), up to the cover plate of the end vent module and attach by fixing the 4 set screws (CP) and washers (CR) to the hank bushes in the end of the silencer box.

2.18.1.3 Re-attach the cover plate (AQ) to the end vent module and fix in position using the 2 set screws (AS).

Dims:

(hwd) □5" x 8" long

Weight: 2lbs



AQ. EVM Outer Plate; AS. EVM Fastener; CN. EVM Silencer - L104051-SUB;  
CP. M6 x 12mm Set Pin - 5417-1; CR. M6 Washer - 5405

### 3. Commissioning Instructions.



These appliances should be commissioned by a qualified engineer.

#### 3.1 Tools Required.

The following tools and equipment are advisable to complete the tasks laid out in this manual.



Suitable alternative tools may be used.



Various Phillips Screwdrivers



Various Flat Head Screwdrivers



Manometer



Wrench Set



Allen Wrench set

#### 3.2 General.

On completion of installation testing and balancing should be undertaken by a competent gas engineer following the instructions provided by the manufacturer. Special attention should be given to testing and confirming the correct operation of the ignition and burner fail safe system and the correct setting of the gas pressure.



Under normal working conditions it is recommended that the ARC system is regularly maintained to ensure long life and efficient operation.

Maintenance is required only once per year.

In dusty or dirty conditions more frequent maintenance is desirable. Servicing work must be carried out by a qualified gas service engineer.

##### Important

When maintaining or servicing the systems:

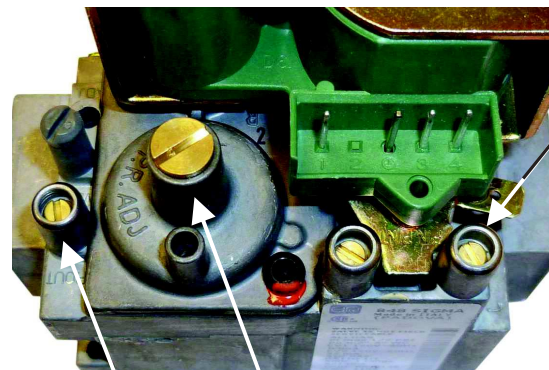
-  Never rest anything, especially ladders against heating system.
-  Isolate gas and electrical supplies before commencing any service work.

3.3.1.3 Ensure that each burner is electrically disconnected at the plug/socket.

3.3.1.4 Set individual burner delay timer dip-switches (located in each burner) to required setting. **Refer to section 3.3.1.8**

3.3.1.5 Check gas is turned on at meter and take meter gas pressure reading.

Fit pressure manometer to the inlet pressure test point on the burner furthest from the gas supply and with all burners off observe pressure reading. Turn off gas at meter and again observe reading. If pressure falls check system for leaks.



Gas inlet test point

Injector pressure test point.

Adjustment screw under cap to set injector pressure

#### 3.3 Commissioning Procedure

##### 3.3.1 Start Up Checks

3.3.1.1 Check that the installation is to the design layout drawing and installed in accordance with the installation instructions.

3.3.1.2 Check installation electrically. Ensure that the vacuum fan, burners and control panel are wired correctly to diagrams provided.

**The gas pressure at the burner inlet connection must not exceed 20in w.c..**

3.3.1.6 Start the vacuum fan.

For various controllers/BMS systems it may be necessary to adjust the set point to above room temperature.

3.3.1.7 Check for correct fan rotation.

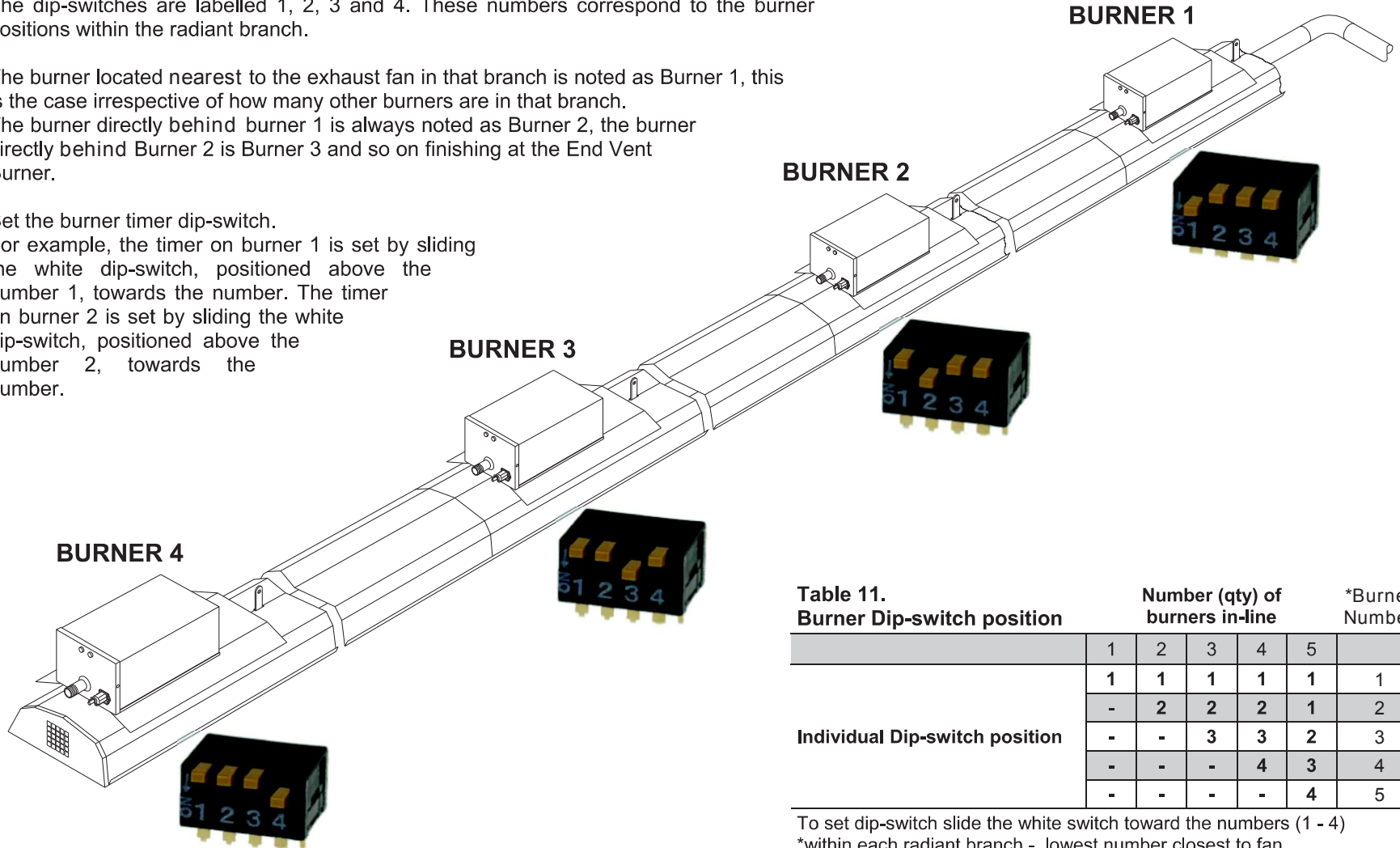
Each burner is fitted with an adjustable burner delay timer. The timer is adjusted using dip-switches located on top of the timer casing.

The dip-switches are labelled 1, 2, 3 and 4. These numbers correspond to the burner positions within the radiant branch.

The burner located nearest to the exhaust fan in that branch is noted as Burner 1, this is the case irrespective of how many other burners are in that branch. The burner directly behind burner 1 is always noted as Burner 2, the burner directly behind Burner 2 is Burner 3 and so on finishing at the End Vent Burner.

Set the burner timer dip-switch.  
 For example, the timer on burner 1 is set by sliding the white dip-switch, positioned above the number 1, towards the number. The timer on burner 2 is set by sliding the white dip-switch, positioned above the number 2, towards the number.

69



**Table 11. Burner Dip-switch position**

Burner Dip-switch position	Number (qty) of burners in-line					*Burner Number
	1	2	3	4	5	
1	1	1	1	1	1	1
- 2	-	2	2	2	1	2
- - 3	-	-	3	3	2	3
- - - 4	-	-	-	4	3	4
- - - - 5	-	-	-	-	4	5

To set dip-switch slide the white switch toward the numbers (1 - 4)  
 \*within each radiant branch - lowest number closest to fan

### 3.4 Set up

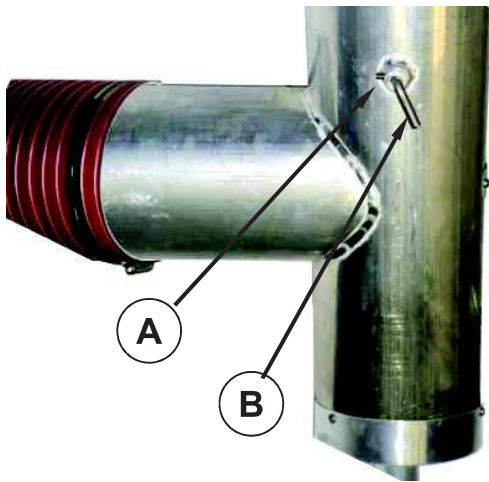
End vent vacuum settings are made firstly by means of adjusting the damper at the vacuum fan inlet, this brings the end vent with the lowest reading to the normal operating vacuum.

The dampers on each branch can then be adjusted to bring the vacuum readings in other branches to the normal operating figure.

Ensure that all dampers are locked securely after adjustment.

3.4.1 Ensure that each burner is electrically disconnected at the end vent module plug/socket.

3.4.2 Check vacuum fan inlet and branch dampers are fully open in the first instance and secure.



The fan inlet damper is integral to the fan inlet condensate tee piece.

- 1 Loosen grub screw (A).
- 2 Turn adjustment lever (B).
- 3 Position of the damper blade is indicated by position of bent adjustment lever.
- 4 Tighten grub screw (A) to secure damper position when finished.

3.4.3 Ensure the controller is in a programmed ON and above the actual room temperature.

3.4.4 After a 30s delay the fan should run.

3.4.5 Working at the end vent burner FURTHEST AWAY from the fan, measure the vacuum pressure and adjust the **fan inlet damper** to obtain above 3.6in w.c. **WHEN COLD.**

The end vent vacuum is measured by inserting a small tube through the end vent orifice.

3.4.6 Remove power to the system and allow fan to halt.

3.4.7 Ensure that each burner is electrically re-connected at the end vent module plug/socket.

3.4.8 Return power to system. After a 30s delay the fan should run and a red neon should have illuminated on the rear of each burner.

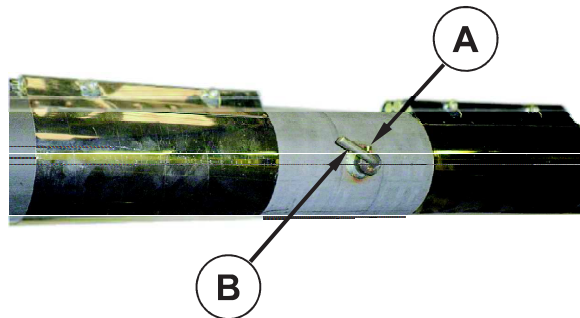
3.4.9 Working once more at the radiant branch FURTHEST AWAY from the fan, observe the ignition of the burners. An amber neon should illuminate on the rear of the burner.

3.4.10 If the dip-switches have been set correctly, the burner closest to the manifold (last on branch) should ignite first followed in order by every burner towards the end vent burner.

Note: It may be necessary to temporarily break the union at a burner in order to purge the gas pipe of air.

Allow the branch to run for 30 minutes.

3.4.11 Recheck the end vent burner FURTHEST AWAY from the fan, measure the vacuum pressure. Adjust the **branch damper** to obtain above 2.5in w.c. **WHEN HOT.**



Adjustment instruction for branch damper.

- 1 Loosen grub screw (A).
- 2 Turn adjustment lever (B).
- 3 Position of damper blade is indicated by position of bent adjustment lever.
- 4 Tighten grub screw (A) to secure damper position.

3.4.12 Repeat for any further branches (where necessary), moving closer to the fan as each branch is completed.

The vacuum setting procedure is now complete

### 3.5 Final Commissioning.

3.5.1 Check that the burner injector pressures are zero  $\pm 0.1$  in w.c.. Adjust if necessary.

3.5.2 Check operation of thermostat controllers a number of times, allowing the burner ignition cycle to complete each time, checking that each burner relights.

3.5.3 With all burners firing check the inlet gas pressure at the burner furthest away from the gas supply.

The minimum inlet pressure is 4.8 in w.c.

The difference between gas pressure at the burner, with all the burners on and all the burners off should not be more than 1 in w.c.

3.5.4 Take gas consumption meter readings for each separate ARC system or building heated ensuring all other loads are off.

3.5.5 After the system has reached equilibrium: take the following measurements.

a The flue gas temperatures entering the vacuum fan. The flue gas sample point located on the vacuum fan tee is used.

b The surface temperature of the underside of the tube at the end of each radiant branch.

c The surface temperature of the underside of the tube at a point directly underneath each combustion chamber suspension lug.

3.5.6 Reset thermostat controllers to required setting.

3.5.7 Complete service report sheet.

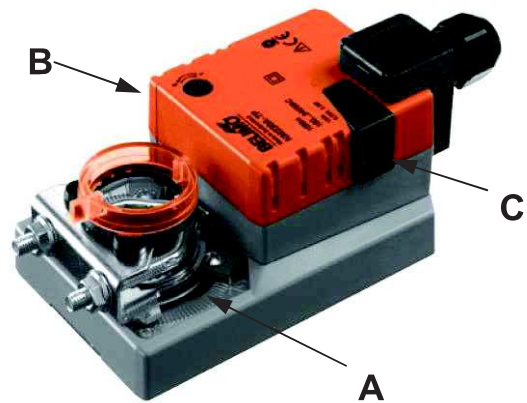
### 3.6 Optional Motorised Hi/Lo End Vent Suction Setting Procedure

The high/low fire end vent suction adjustment is made using the fan damper. Suction figures are shown as **HOT SETTINGS**.

#### 3.6.1 Setting Maximum Fire End Vent Suction.

1. Isolate supply from the motorised damper.
2. Press and hold the manual override button (C) - damper can now be adjusted manually.
3. Rotate damper spindle until end vent suction of between 2.5" to 3" W.C. is achieved. Release the manual override button.

4. Using a phillips screwdriver, reposition the mechanical end stop (A) to final bracket position.
5. Reconnect power to damper. Check correct direction of rotation (i.e. when 10Vdc from controller = damper fully open). If this is not correct, use a flat head screwdriver and change the direction switch (B).



#### 3.6.2 Setting Minimum Fire End Vent Suction.



1. Isolate supply from the motorised damper.
2. Press and hold the manual override button (C) — damper can now be adjusted manually.
3. Rotate damper spindle until low fire end vent suction of between 0.5" to 1" W.C. is achieved. Release the manual override button (C).
4. Using a phillips screwdriver, reposition the mechanical end stop (A) to final bracket position.
5. Reconnect power to damper. Recheck correct direction of rotation (i.e. when 10Vdc from controller = damper fully open). If this is not correct, use a flat head screwdriver and change the direction switch (B).

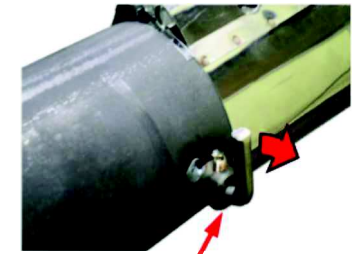
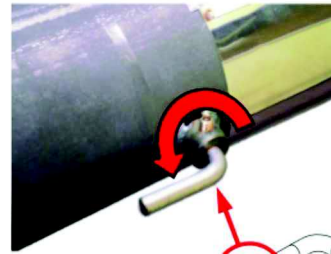
### 3.6.3 Option Damper Technical details

		Heater Model			
		ARC18LR(M)	ARC24LR(M)	ARC32LR(M)	ARC38LR(M)
Minimum Fire BTU		30,000	39,000	52,000	63,000
Maximum Fire BTU		74,000	98,000	130,000	155,000
Jet Size	LPG	L100535 (3.5mm)	L100540 (4.0mm)	L100544 (4.4mm)	L100548 (4.8mm)
	Nat Gas	L100544 (4.4mm)	L100549 (4.9mm)	L100554 (5.4mm)	L100558 (5.8mm)
Shutter Plate		L100321 (17mm)	L100320 (19.5mm)	L100314 (22mm)	L100316 (24mm)
End Vent Orifice Plate		L104102 (16mm)	L104101 (24mm)	L104100 (27mm)	L104103 (28mm)
<b>End Vent Suction (All Models)</b>					
Minimum Fire		0.5" to 1" W.C.			
Maximum Fire		2.5" to 3" W.C.			

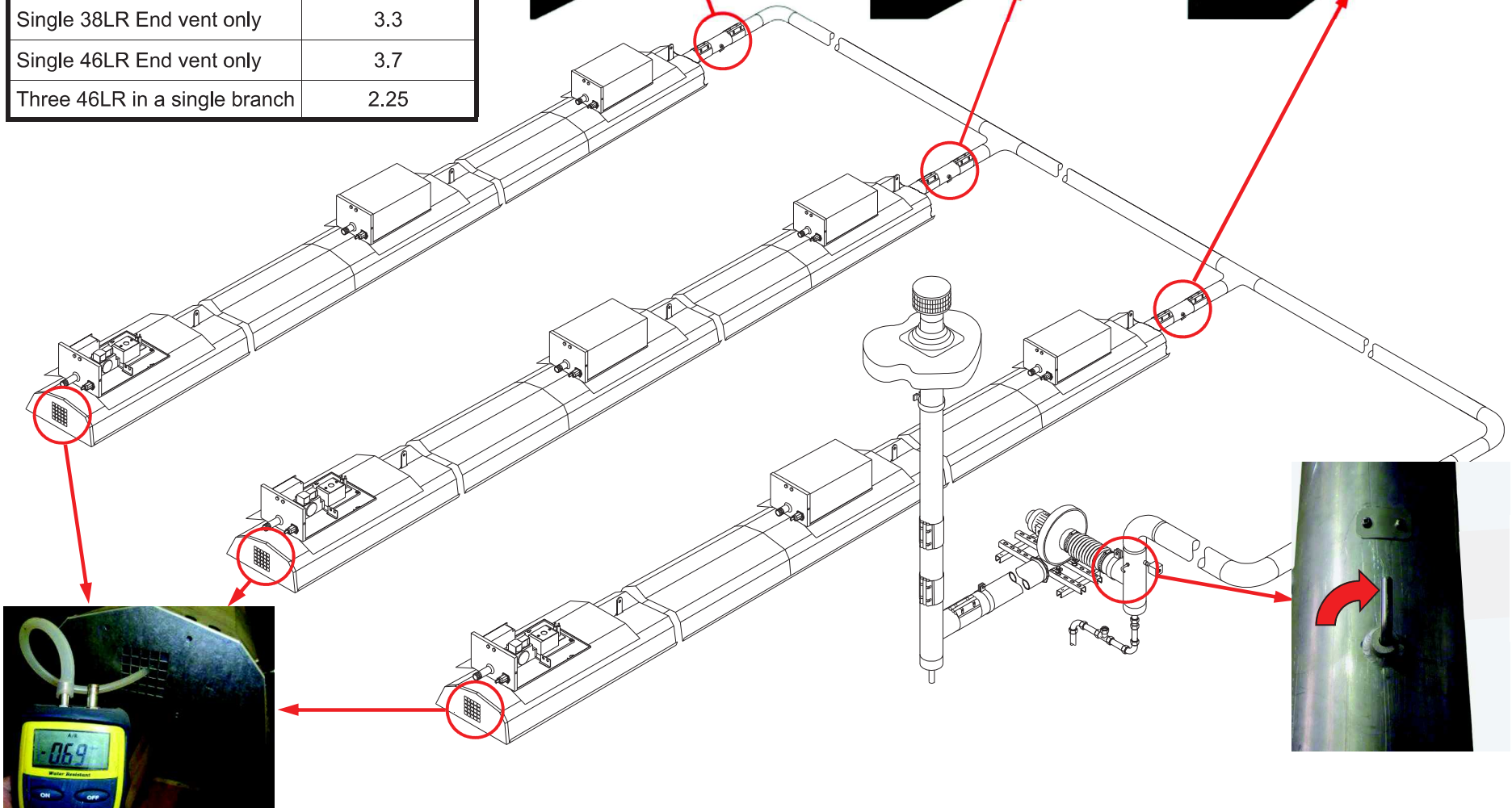
**Nb: Please contact an AmbiRad representative for installations over 4000' elevation**

### 3.7 Typical U

System	End vent Pressure HOT in w.c.
Standard systems - shown	2.5
Special considerations	
Single 32LR End vent only	3.0
Single 38LR End vent only	3.3
Single 46LR End vent only	3.7
Three 46LR in a single branch	2.25



64





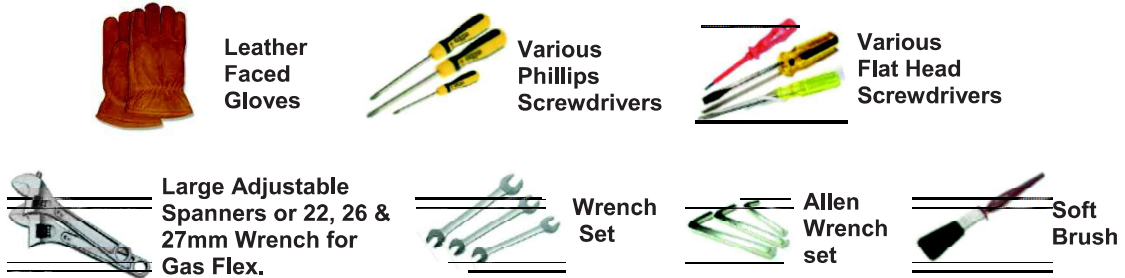
# 4. Servicing Instructions.

**!** These appliances should be serviced annually by a competent person to ensure safe and efficient operation. In exceptional dusty or polluted conditions more frequent servicing may be required.  
 The manufacturer offers a maintenance service. Details available on request

## 4.1 Tools Required.

**i** Suitable alternative tools may be used.

The following tools and equipment are advisable to complete the tasks laid out in this manual.

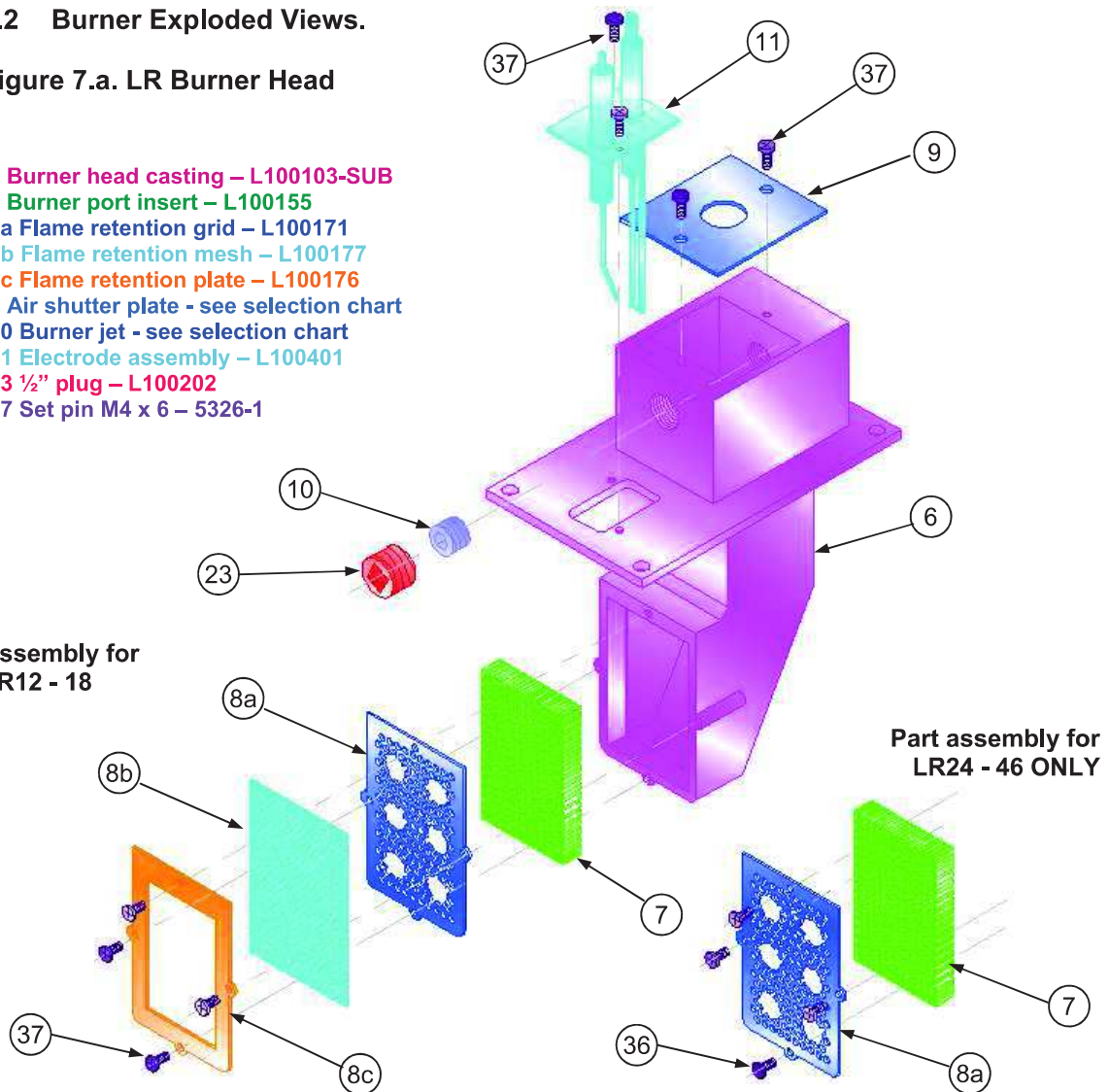


## 4.2 Burner Exploded Views.

Figure 7.a. LR Burner Head

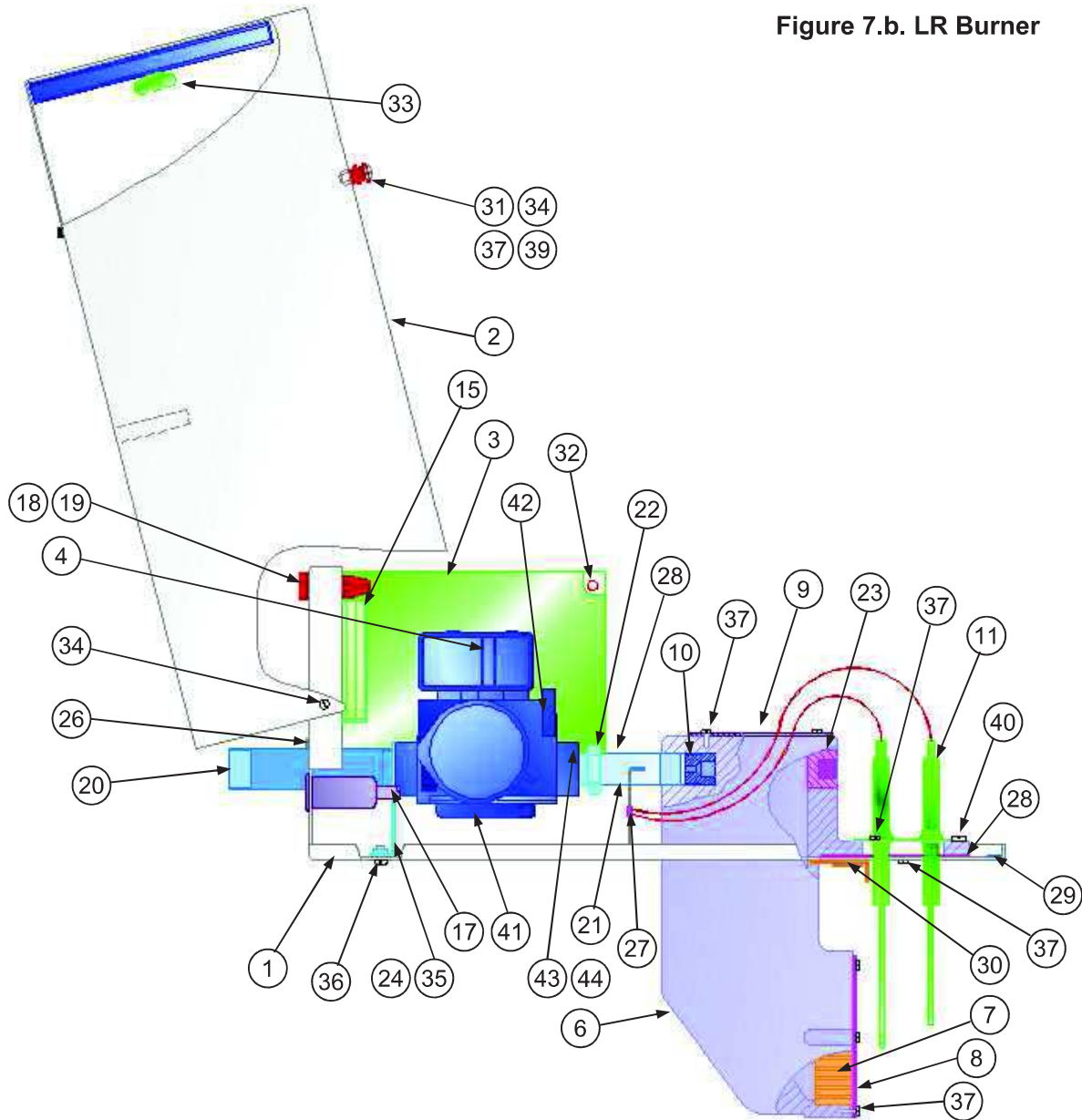
- 6 Burner head casting – L100103-SUB
- 7 Burner port insert – L100155
- 8a Flame retention grid – L100171
- 8b Flame retention mesh – L100177
- 8c Flame retention plate – L100176
- 9 Air shutter plate - see selection chart
- 10 Burner jet - see selection chart
- 11 Electrode assembly – L100401
- 23 ½" plug – L100202
- 37 Set pin M4 x 6 – 5326-1

Assembly for LR12 - 18



Part assembly for LR24 - 46 ONLY

Figure 7.b. LR Burner



- 1 Control housing base plate – L102001
- 2 Control housing lid – L102009
- 3 Full sequence gas controller – 3256-11
- 4 Multi functional gas valve – 2056 plus 900041
- 5 Air filter – L102013
- 6 Burner head casting – L100103-SUB
- 7 Burner port insert – L100155
- 8 Flame retention grid – L100171
- 9 Air shutter plate - see selection chart
- 10 Burner jet - see selection chart
- 11 Electrode assembly – L100401
- 15 Delay timer – L102025-SUB
- 17 Wiring harness – E200107
- 18 Red neon light – 2180
- 19 Amber neon light – 2175
- 20 Gas inlet connection pipe 1/2" x 4" – 2360
- 21 Gas outlet inlet connection pipe 3/8" x 2 1/2" – 2314-1
- 22 1/2" x 3/8" reducing bush – 2320

- 23 1/2" plug – L100202
- 24 Valve mounting bracket – L102020
- 26 Grommet (gas supply) – B200500
- 27 Grommet (13mm) – 2878
- 28 Burner gasket – L102032
- 29 Silicone gasket – L102031
- 30 Slide latch – L100200
- 31 Latch clip – L100201
- 32 Push clip – C110714
- 33 Wing nut – C111700
- 34 Set pin M4 x 12 – 5325
- 35 Set pin M4 x 10 – 5314
- 36 Set pin M5 x 10 – 5363
- 37 Set pin M4 x 6 – 5326-1
- 38 Washer M4 – 5322
- 39 Nut M4 – 5315
- 40 Torque Screw - 201093

#### 4.3 Vacuum fan



Inspect fan and flue ductwork for any contamination.

Inspect expansion joints for damage and replace if necessary.

#### 4.4 Tubes



Inspect radiant tubes and fittings internally. If there is any appreciable build up of dust or deposits the tubes should be cleaned internally.

If corrosion is present replace as necessary.

Note It may be necessary to determine whether chlorinated hydrocarbons are being used by the client.

#### 4.5 Tube couplers



Check for tightness. Inspect for evidence of holes and cracks and replace if necessary.

#### 4.6 Reflectors



Check for overlaps and re-adjust if necessary. The reflectors may be cleaned with a soft cloth and detergent in water.

#### 4.7 Condensate trap



Inspect for dirt and scale and clean if necessary.

#### 4.8 Burner electrodes



Check ceramic visually for build up of carbon or cracks. Check the spark distance and position of the electrodes relative to the burner head, replace if necessary (see fig.8).

#### 4.9 Burner head



Check condition of burner head insert and flame retention grid and replace if necessary.

#### 4.10 Filter



Replace if contaminated with dirt.

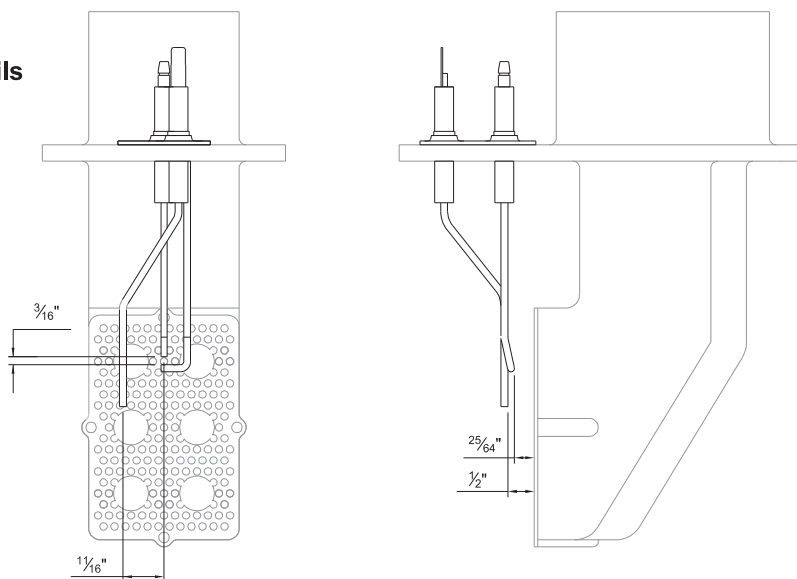
#### 4.11 Combustion Chamber Viewing Window



Window should be clean and free from cracks.

 **Re-commission system after servicing (see section.3)**


Figure 8.  
Burner Electrode Details



## 5. Spare Parts

### Required Spares




In order to aid troubleshooting and servicing we recommend that the components shown in this section should be stocked.

 Note Any spare part components that are not approved by AmbiRad could invalidate the approval of the appliance and validity of the warranty.

Item	Description	Part No.	Item	Description	Part No.
	Ignition Controller	3256-11		Amber Neon (Burner On)	2176
	Nat Gas Valve Twin Solenoid 220/240	2056		Red Neon (Mains On)	2181
	Valve Mini Harness	900041		Burner Timer	L102026
	Mains input Cable Gland & Nut	3231-3 3231-4		Main Harness	E200107
	Ignitor Assembly	L100401		Lockout Relay	2104-1
	HT Spark Lead	2243-1		Lockout Relay Base	2108
	Rectification Lead	2243-2		Burner Gasket	L102032
	Burner Air Filter	L102013		Ceramic Insert	L100155
	Webber Valve	3255		Mica Window	A523500
	Sight Glass Cover	A571202		Window Gasket	C110350

Item	Description	Part No.	Item	Description	Part No.
	End Vent Module	EVM		Burner Head Assembly LR12-18 LR24-46	L100102-SUB12-18 L100102-SUB
	Fan F100NA F200NA F200NA3P	F100NA F200NA F200NA3P		Flame Retention Grid LR12-18 LR24-46	L100175-SUB L100171
	Fan F300NA	F300NA		Vacuum Proving Switch	L104045
	100mm (4") Tube Coupler	C112110		Damper Motor	N9002
	150mm (6") Tube Coupler	C112120		Fan Expansion Joint 4" 6"	7531 7532
	Combustion Chamber	L101020-SUB		Jubilee Clip 4" 6"	7541 7542
	Combustion Chamber Reflector Stainless Steel Aluminium Aludip	L105053 L105060 L105050		Suspension Bracket	L201020
	Standard Reflector Stainless Steel Aluminium Aludip	L201030 L201031 L201032		Reflector Support Bracket	L201008-SUB
	End Cap Stainless Steel Aluminium Aludip	L105023 L105041 L105043		Speedlinks	6524

**NRV LR Injector/Air Shutter selection chart**

Gas	Burner	 Jet Size dia mm Part number		 Sutter Size dia mm Part number		 EVM Orifice Plate dia mm Part number	
		Jet Size dia mm	Part number	Sutter Size dia mm	Part number	EVM Orifice Plate dia mm	Part number
Natural G20	12	3.6	L100536	13	L100322	14.5	L104102
	18	4.4	L100544	17	L100321	16	L104101
	24	4.9	L100549	19.5	L100320	24	L104100
	32	5.4	L100554	22	L100314	27	L104093
	38	5.8	L100558	24	L100316	32	L104092
	46	6.3	L100563	26.5	L100318	-	-
Propane G31	12	2.9	L100529	13	L100322	14.5	L104102
	18	3.5	L100535	17	L100321	16	L104101
	24	4.0	L100540	19.5	L100320	24	L104100
	32	4.4	L100544	22	L100314	27	L104093
	38	4.8	L100548	24	L100316	32	L104092
	46	5.2	L100552	26.5	L100318	-	-

## 6. Fault Finding Guide.

Symptoms	Possible causes	Remedy
Vacuum fan is running but there is no power at burner. Neon lights are off.	Thermostat is satisfied.	Check to see that thermostat is calling for heat.
	No power at burner.	Check for 240V supply.
	Blown fuse in supply to heater.	Check and replace if necessary.
	End vent vacuum too low.	Vacuum at end vent should be 6.25 mbar (2.5in w.c.). Check for air leaks on burner.
	Air pressure switch on end vent burner not opening.	Check and replace if necessary.
Red neon comes on but ignition sequence does not start and amber neon remains off.	3 way air valve (if fitted) in end vent burner not opening.	Check and replace if necessary.
	Loose or broken leads to full sequence gas controller.	Check and repair.
Red neon comes on. Amber neon comes on for ignition period; then amber neon goes off.	Fault in full sequence gas controller.	Replace.
	No ignition spark.	Check for loose or broken high tension lead to spark electrode. Check spark gap and position for spark electrode Check ceramic is not cracked. Check for loose earth wire connection on full sequence gas controller.
	Fault in full sequence gas controller.	Replace.
	Insufficient gas supply to burner.	Check service cock is open and gas pressure is available at inlet to gas valve.
	Gas solenoid valve not opening.	Check for loose or broken wires to the gas valve. Check for adequate end vent vacuum. Replace valve if necessary.
	Injector pressure not set at zero.	Check and adjust.
Red neon comes on. Amber neon comes on for ignition period, burner lights for a short time and then goes out. Amber neon off.	Incorrect aeration.	Check that air shutter plate on mixing chamber is correctly positioned.
	Flame probe faulty or lead detached.	Check for broken ceramic. Check for correct position of flame probe.
	Fault in sequence gas controller.	Measure flame current. The minimum signal is 3 $\mu$ A (DC).
	Polarity of line and neutral incorrect.	Check for correct polarity of the electrical supply.
	Burner earth is poor.	Check and ensure burner is correctly earthed.
	Full sequence gas controller faulty.	Replace.
End vent vacuum too low (ie below 6.25 mbar (2.5in w.c.). Check section 3, commissioning for exact vacuum details.	Incorrect aeration.	Check that air shutter plate on mixing chamber is correctly positioned.
	Branch damper closed or broken.	Open branch damper until end vent vacuum is 6.25 mbar (2.5in w.c.). Replace damper if necessary.
	Fan rotation incorrect.	Reverse two phase wires on 3 phase motors.
	Fan speed wrong.	Check voltage at motor. Replace if necessary.
	Fan impeller loose or defective.	Tighten or replace if necessary.
	Restriction to fan inlet.	Clear restriction, repair flue duct.
	Air leaks into system via poor joints.	Replace defective tube couplers gaskets or acoustic joints.
	Insufficient fall of system towards fan allowing condensate blockage.	Reinstate system fall.
Non return valve sticking open on condensate trap assembly.	Clean valve or replace if damaged.	

## 7. Replacing Parts



### 7.1 Removal of burner assembly.

- a Disconnect electrical supply at burner mains inlet connection.
- b Turn-off gas supply at service cock and disconnect union.
- b1 On EVM burners, remove the vacuum tubes by releasing the two compression fittings (14).
- c Release the slider latches (30) from the underside of the burner base plate (1).



- d Pull lid (2) apart and upwards from base (1). Lid is attached to back plate via 2 screws (34).
- e Remove lid by unscrewing set pins (34) from back of base plate.
- f Remove spark electrode assembly (11) (see section 7.6)
- g Release and remove the four set screws (40) from the combustion chamber flange. Retain combustion chamber gasket (28).



- h Lift burner clear of combustion chamber and withdraw.

- i Remove the burner heat shield.

j When replacing do so in the reverse order ensuring that the gasket between the burner heat shield and combustion chamber (28) is undamaged or replaced.

- k Check for gas soundness.

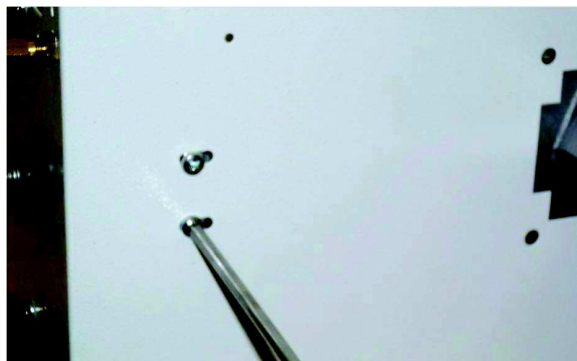


### 7.2 Removal of gas valve.

- a Remove burner assembly from combustion chamber as detailed in 7.1.

- b Secure burner head (6) and unscrew gas inlet pipe (21).

- c Remove burner set screws (37) and valve bracket set screws (36) from burner base plate.



- d Withdraw burner head and valve from base plate. Retain burner gasket for later (28).

- e Secure burner head (6) and unscrew gas valve (4).

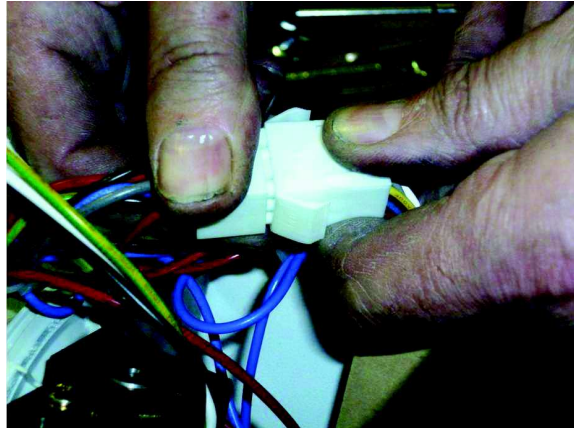
- f Replace in reverse order.





c Pull lid (2) apart and upwards from base (1).

d Disconnect JST connection (3a).



### 7.3 Filter Replacement.

a Release the slider latches (30) from the underside of the burner base plate (1).

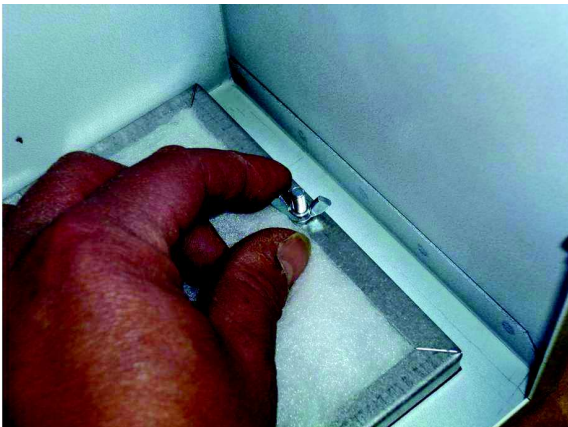
b Pull lid (2) apart and upwards from base(1).

c Unscrew wing nut fastener (33).

e Disconnect ignition wire from controller (3b).

f Release three push clips (32) from controller fixing holes.

g Remove controller (3)



h Replace in reverse order.

d Slide filter (5) out of location brackets.

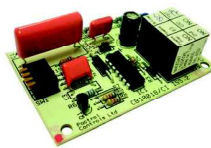
e Replace in reverse order.



### 7.4 Controller Replacement

a Disconnect electrical supply.

b Release the slider latches (30) from the underside of the burner base plate.



### 7.5 Sequence Timer Replacement.

a Disconnect electrical supply.

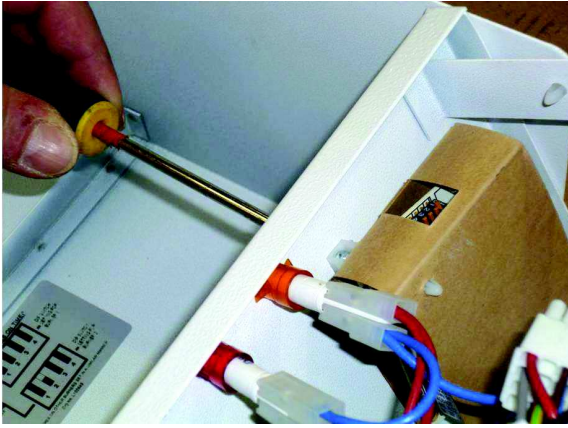
b Release the slider latches (30) from the underside of the burner base plate.

c Pull lid (2) apart and upwards from base (1).

d Remove controller as described in section 7.4

e Disconnect electrical connection from the timer.

**f** Remove fixing screws from timer bracket and withdraw.



**g** Remove timer from the insulation wrap and remove unit.

**h** Replace in reverse order.



### 7.6 Electrode Assembly Replacement.

**a** Disconnect electrical supply.

**b** Release the slider latches (30) from the underside of the burner base plate.

**c** Pull lid (2) apart and upwards from base (1).

**d** Remove fixing screws (37) from electrode mounting flange (11).



**e** Carefully withdraw electrode assembly from burner - noting electrode orientation.

**f** Replace in reverse order.



### 7.7 Injector Replacement. (See figure 6a)

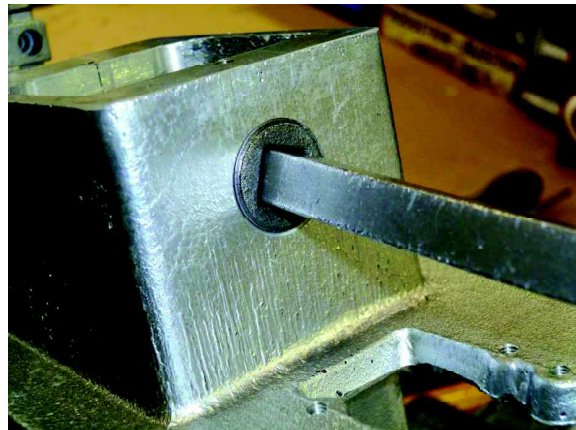
**a** Turn off gas and disconnect electrical supply.

**b** Release the slider latches (30) from the underside of the burner base plate (1).

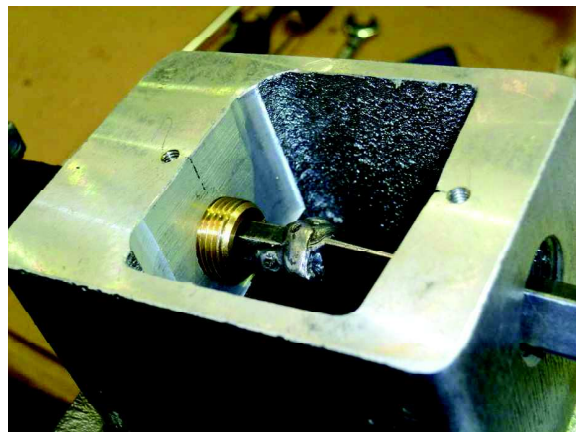
**c** Pull lid (2) apart and upwards from base (1).

**d** remove fixings screws (37) and air shutter plate (9) from top of burner casting.

**e** Remove plug (23).



**f** Unscrew brass jet (10) inside mixing chamber using 8mm allen key and withdraw through 1/2in BSP hole.



**g** Replace in reverse order.



## 7.8 Combustion Chamber Viewing Window Replacement.

- a Turn off the system including the vacuum fan.
- b Unscrew dome nuts (47) and spring washers (48). Remove sight glass cover (49), gasket (50) and mica window (51).



- c Replace in reverse order as shown ensuring components are re-assembled in correct order.



## 8. User & Operating Instructions

AmbiRad is the manufacturer of a series of tubular infra-red heaters designed for overhead heating of industrial and commercial buildings. Individual heating units are suspended from the roof or mounted at an angle on the wall



1. **This appliance must only be installed by qualified craftsmen in accordance with the requirements of local and National Codes.**
2. **This appliance must be grounded in accordance with the National Electrical Code ANSI/NFPA No.70 or Canadian Codes.**
3. **Never rest anything, especially ladders against the heaters.**

### 8.1 To Start the Heater

1. Ensure that gas supply is turned on at each burner.
2. Switch on electrical supply to heaters.
3. Ensure that the controls are correctly set i.e.;

  - Clock is correctly set.
  - Heater program is correctly set.
  - Required room temp is correctly set

4. The vacuum fan will operate and at the same time the **red** neon lights will illuminate at all burners. After 10 seconds the burners closest to the exhaust fan in each radiant branch will light, with both **red** and **amber** neons illuminated. After a further 25 seconds the next burner in line within each radiant branch will light and after a further 25 seconds the end vent burner will light.
- 5 If the lighting up sequence fails and lockout occurs press the lockout reset button (if available), or switch off the electrical supply and restart after 40 seconds. If lockout occurs three times consecutively switch off and isolate the gas and electricity supplies.

Contact Your Local Representative

### 8.2. To Switch Off Heater

1. Switch off electrical supply to the heater. The burner will stop and the fan will shut off.
2. If the heater is to be switched off for periods in excess of one week it is highly recommended that both the gas and the electrical supplies are turned off.

### 8.3. Routine Maintenance between Service Intervals

After ensuring that the heater is cold and mains electric isolated, cleaning of the reflectors with a soft cloth and a mild detergent (non solvent based cleaners only) in water can be undertaken.

Additional removal of dust from the radiant tubes, burner and heat exchanger can be undertaken.

### 8.4 Frequency of Servicing

The manufacturer recommends that to ensure continued efficient and safe operation of the appliance, the heater is serviced annually by a competent person e.g. every year in normal working conditions but in exceptional dusty or polluted conditions more frequent servicing may be required.

#### NORTEK GLOBAL HVAC (UK) LTD

Fens Pool Avenue  
Brierley Hill  
West Midlands DY5 1QA  
United Kingdom

Tel: 01384 489 700  
Fax: 01384 489 707

[ambiradsales@nortek.com](mailto:ambiradsales@nortek.com)  
[www.ambirad.co.uk](http://www.ambirad.co.uk)

# AMBIRAD

HEATING AND VENTILATION SOLUTIONS

AmbiRad is a registered trademark of AmbiRad Limited. Because of continuous product innovation, AmbiRad reserves the right to change product specification without due notice.