Technical Support:

Tel: 01384 489200

Email: ambiradgroupsupport@tnb.com

BENSON

WIRING DIAGRAM MANUAL FOR BENSON VARIANTE² BI DIRECTIONAL



WARNINGS

Installation of Benson Equipment must be carried out in accordance with the current IEE wiring regulations (BS 7671), BS 6896 (Industrial & Commercial) and any other relevant British Standards and Codes of Practice by a qualified installer. All external wiring **MUST** comply with the current IEE wiring regulations.

Wiring Diagram 33-68-004 VRBD 72-95 Auto ignition On/Off

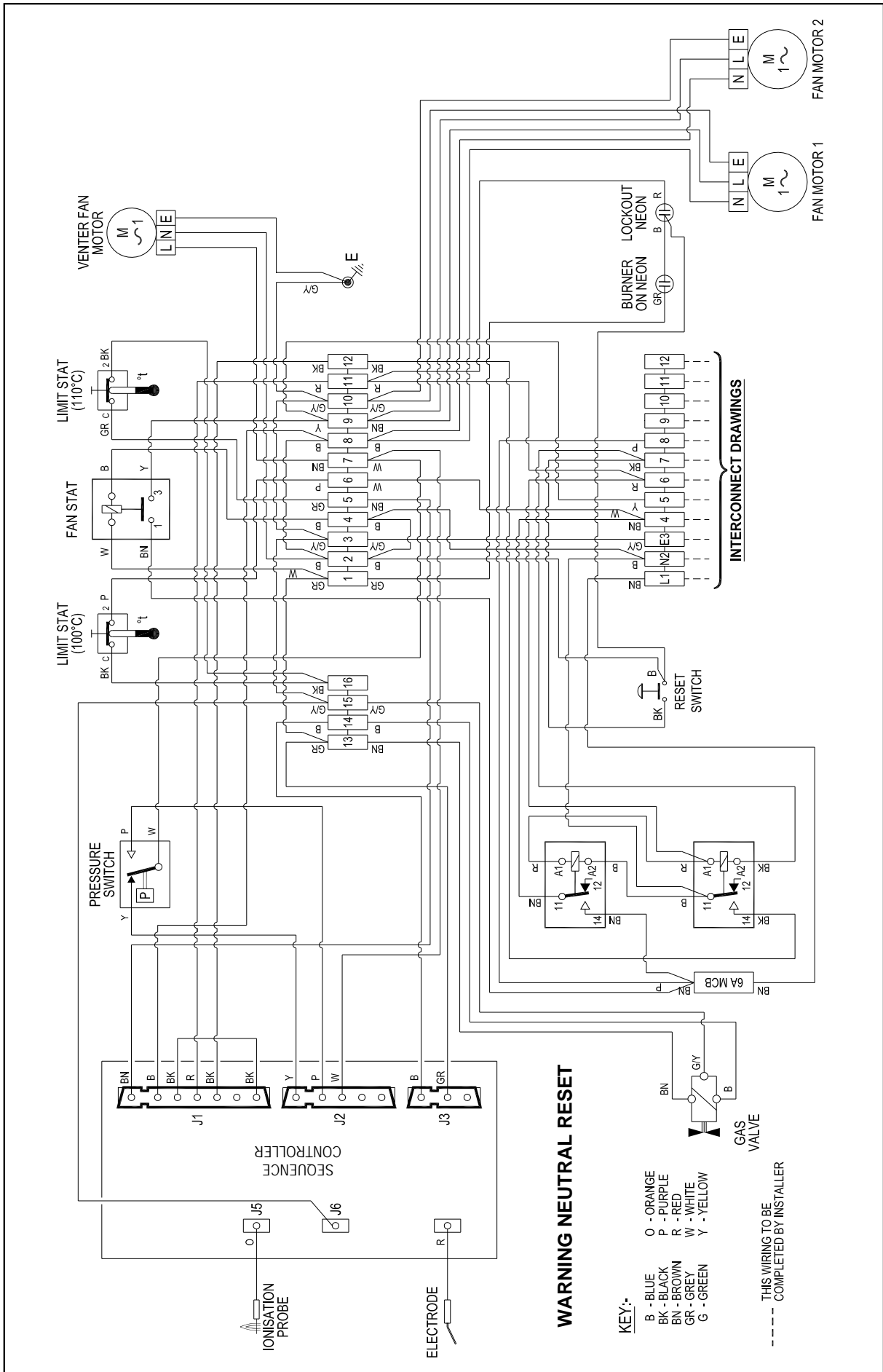

Wiring Diagram 33-68-013 VRBD 120-145 Auto ignition On/Off

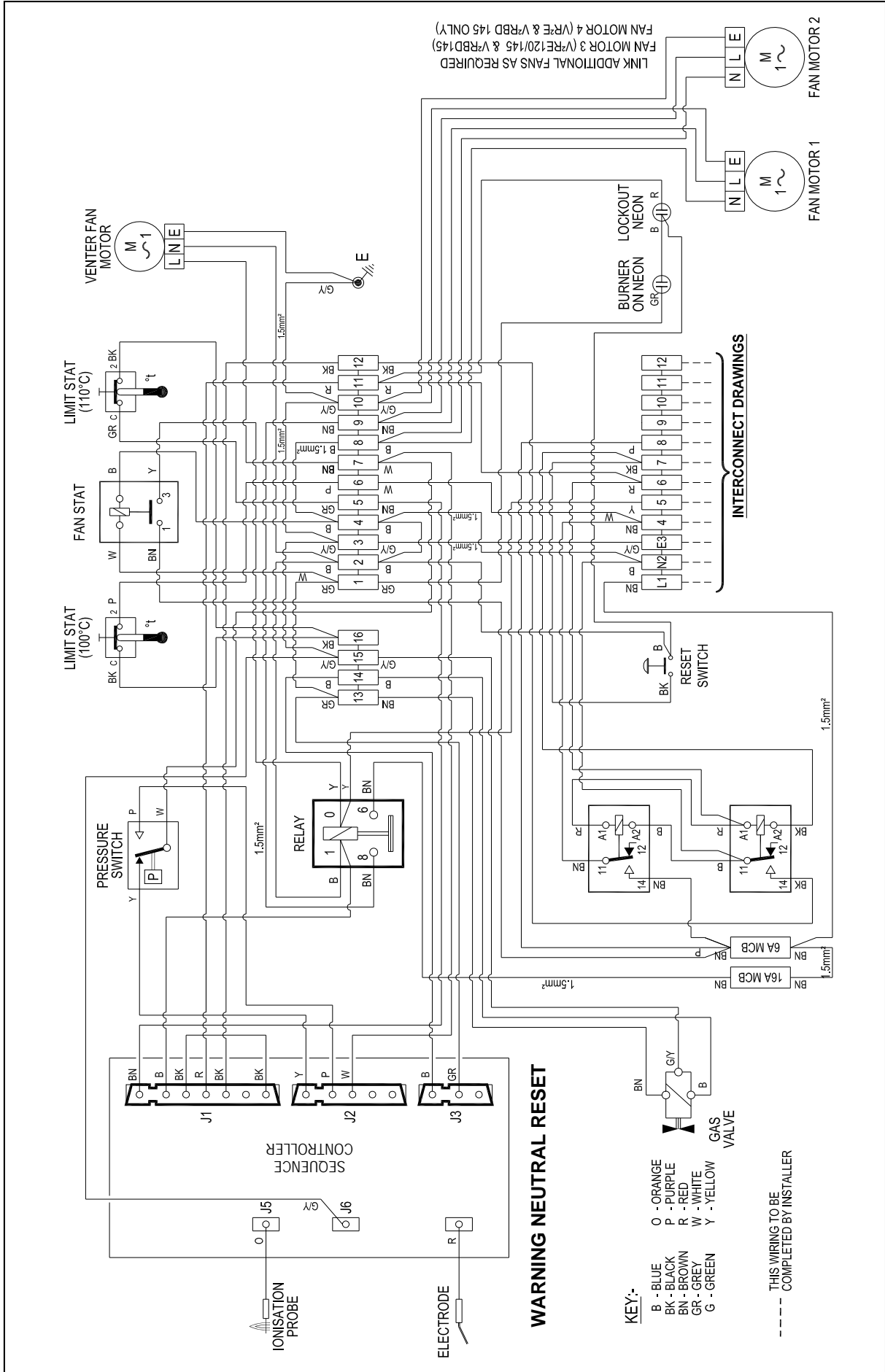

Wiring Diagram 33-68-005 VRBD 72-95 Auto ignition Hi/Low

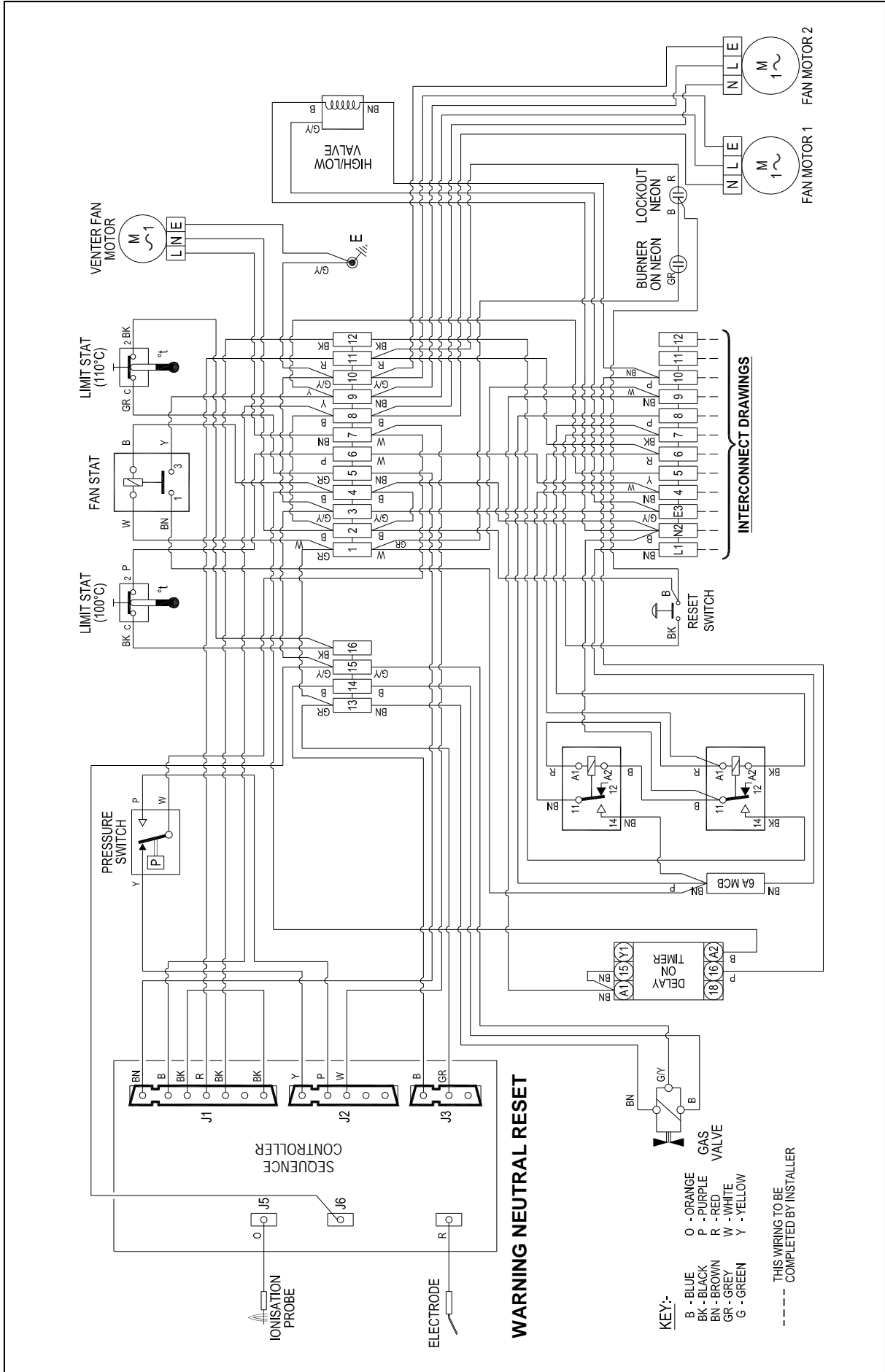

Wiring Diagram 33-68-014 VRBD 120-145 Auto ignition Hi/Low

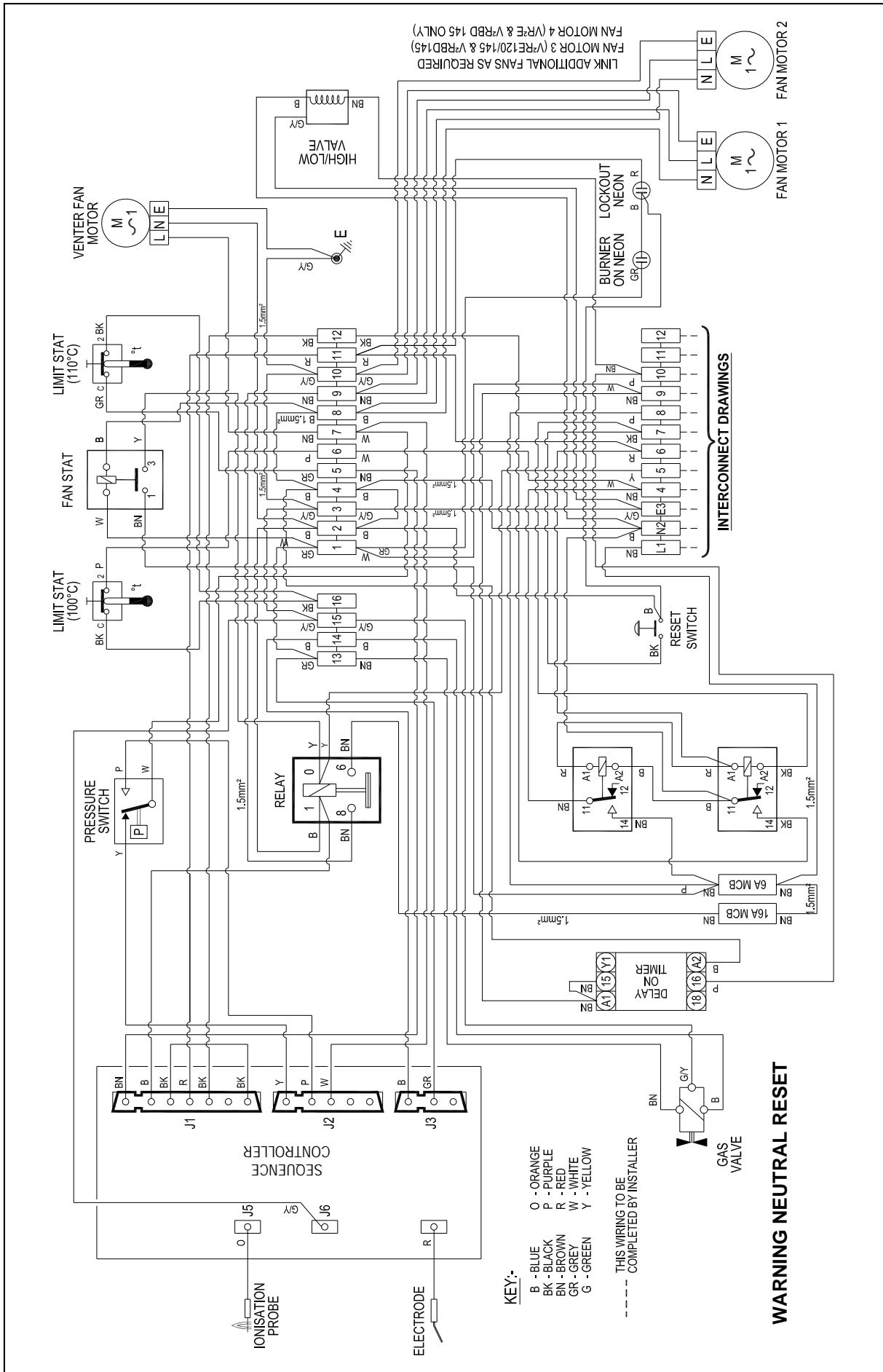

Wiring Diagram 33-67-704 VRBD 72-95 Auto Ignition Modulation

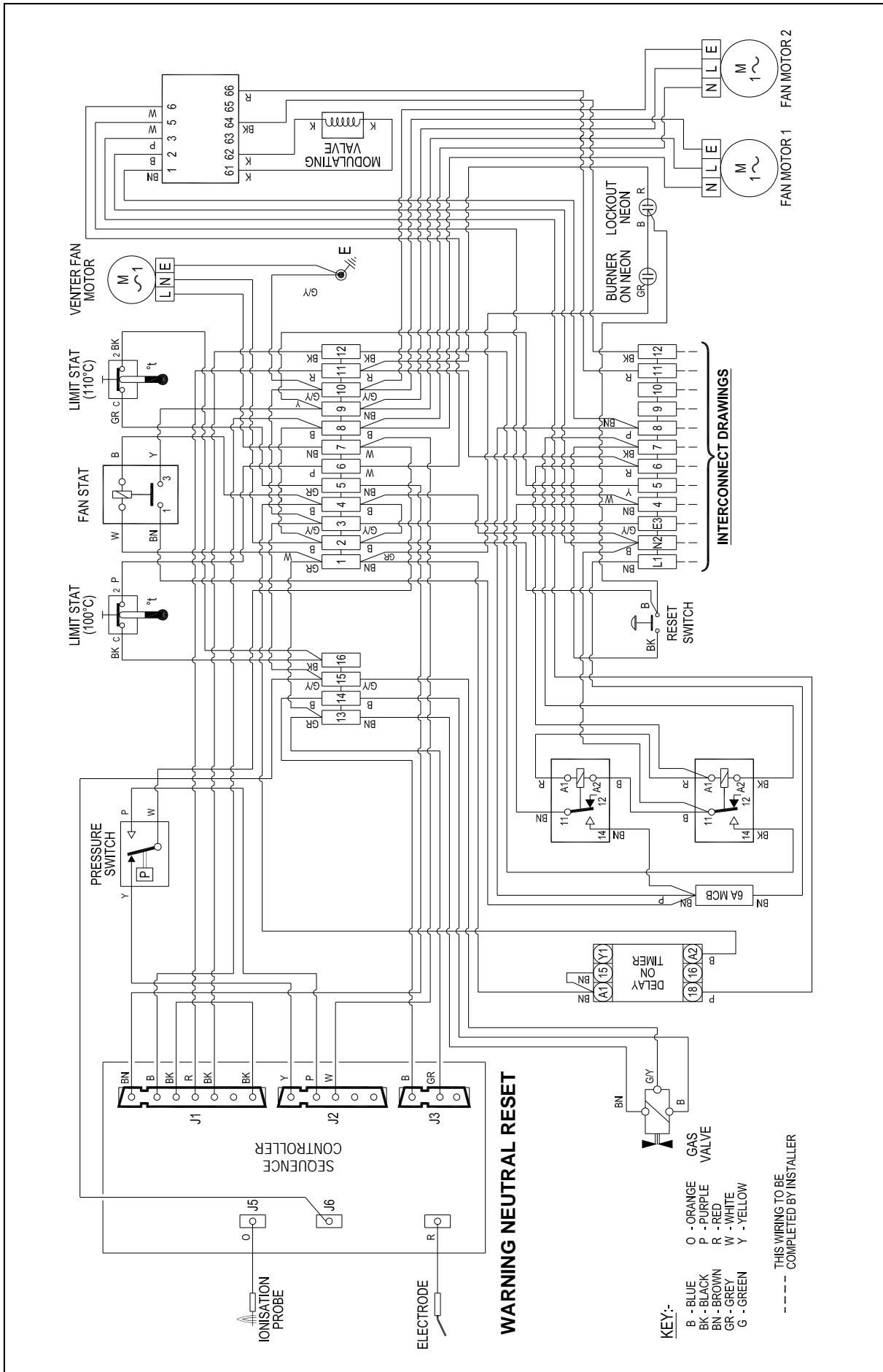

Wiring Diagram 33-67-705 VRBD 120-145 Auto ignition Modulation

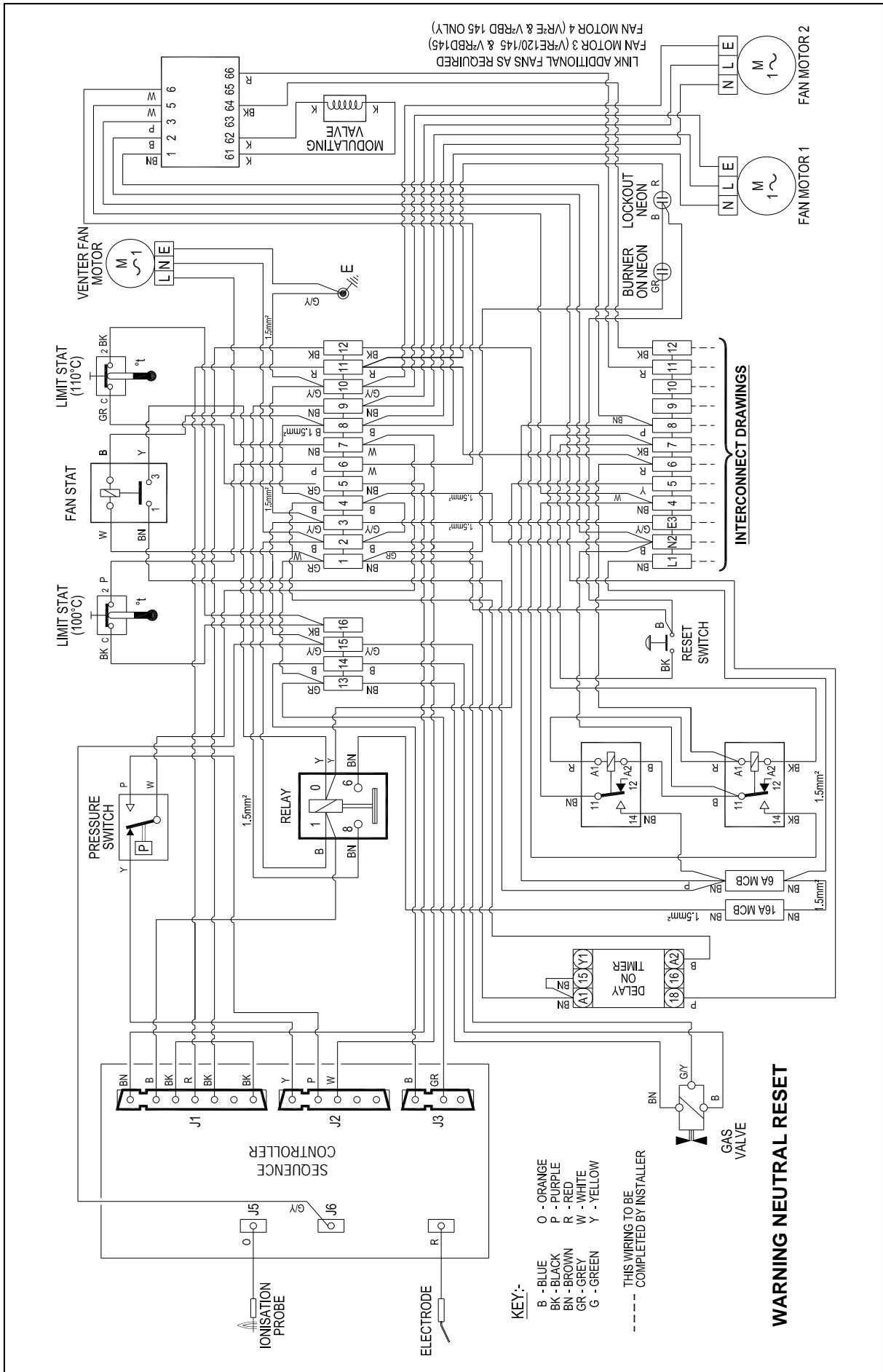

AmbiRad Group

Heating and Ventilation Solutions

Technical Support:

Tel: **01384 489 200**

Fax: **01384 489 707**

ambiradgroupsupport@tnb.com
www.ambiradgroup.co.uk

AMBIRAD AIRBLOC NORDAIRNICHE BENSON

A Thomas & Betts Company. Registered in England No. 1390934. Registered office: 27/28 East Castle Street, London.

AmbiRad UK is a registered trademark of AmbiRad Limited. Because of continuous product innovation, AmbiRad reserves the right to change product specification without due notice.