Technical Support:

Tel: 01384 489200

Email: ambiradgroupsupport@tnb.com

BENSON

WIRING DIAGRAM MANUAL FOR BENSON VARIANTE² TUBULAR HEATERS



WARNINGS

Installation of Benson Equipment must be carried out in accordance with the current IEE wiring regulations (BS 7671), BS 6896 (Industrial & Commercial) and any other relevant British Standards and Codes of Practice by a qualified installer. All external wiring **MUST** comply with the current IEE wiring regulations.

Wiring Diagram 33-68-001 VRA 12-60 VRC 12-30 Auto ignition On/Off

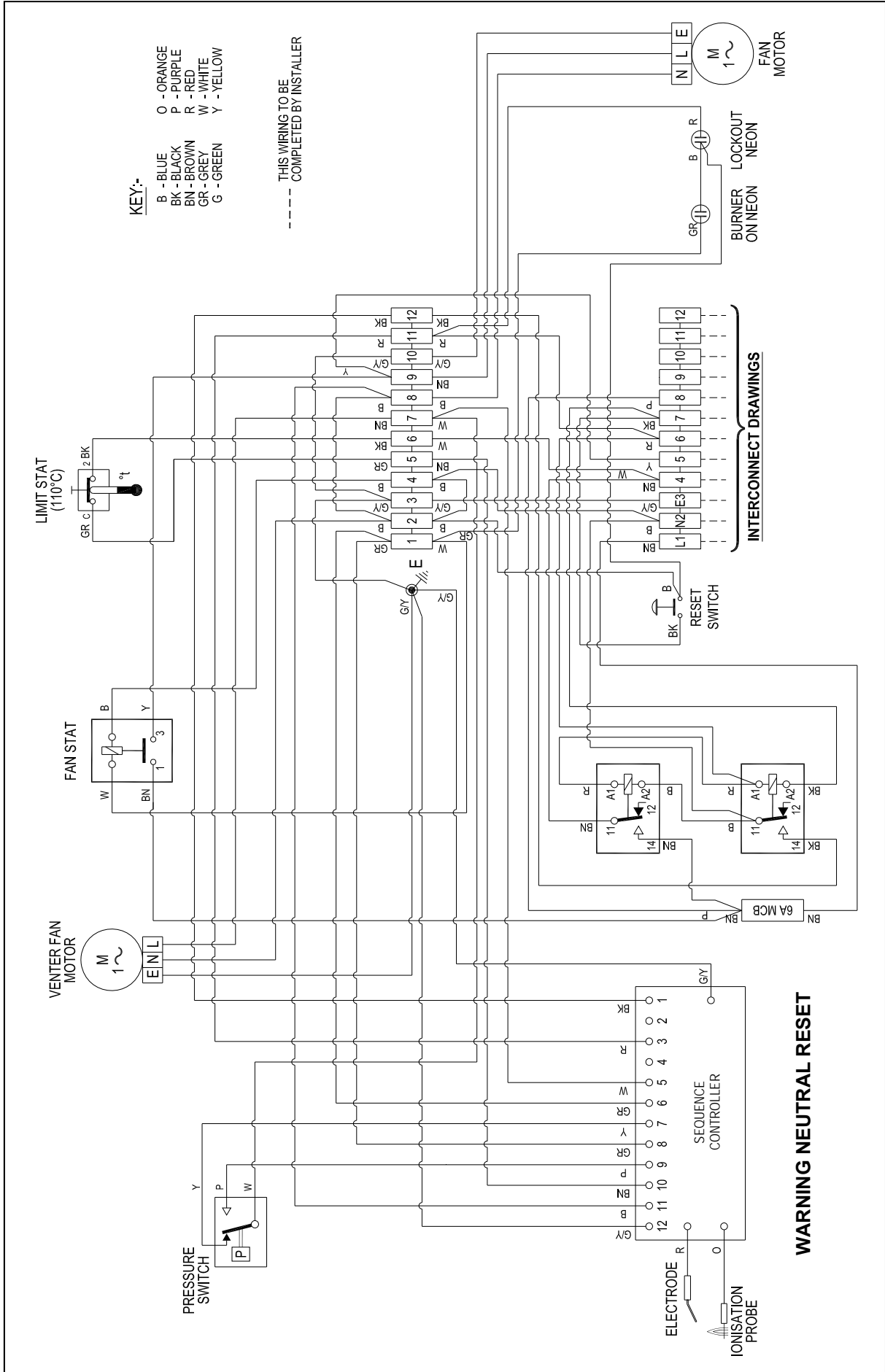

WARNING NEUTRAL RESET

Wiring Diagram 33-68-007 VRC 42 Auto ignition On/Off

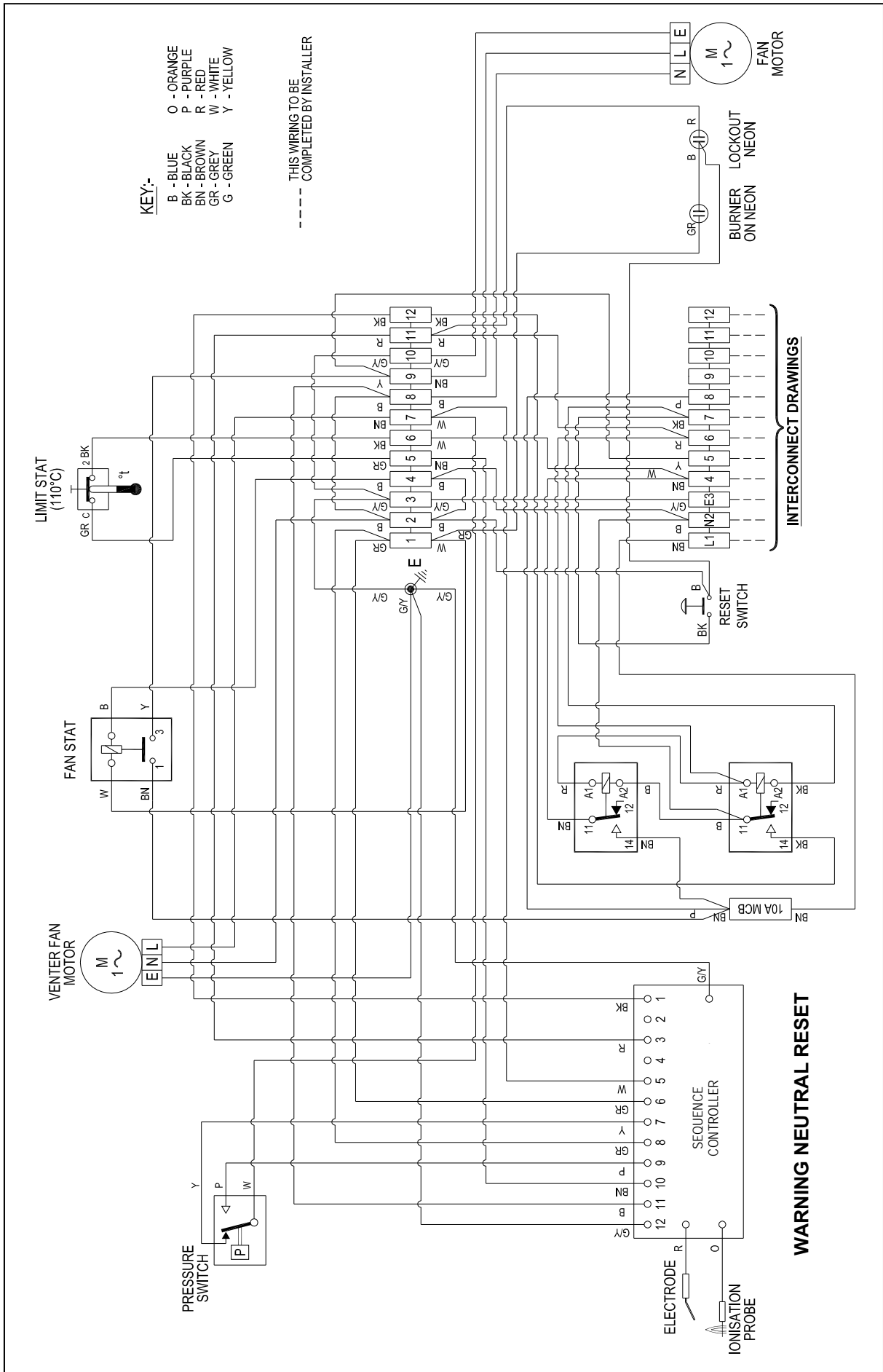

Wiring Diagram 33-68-010 VRC 50-60 Auto ignition On/Off

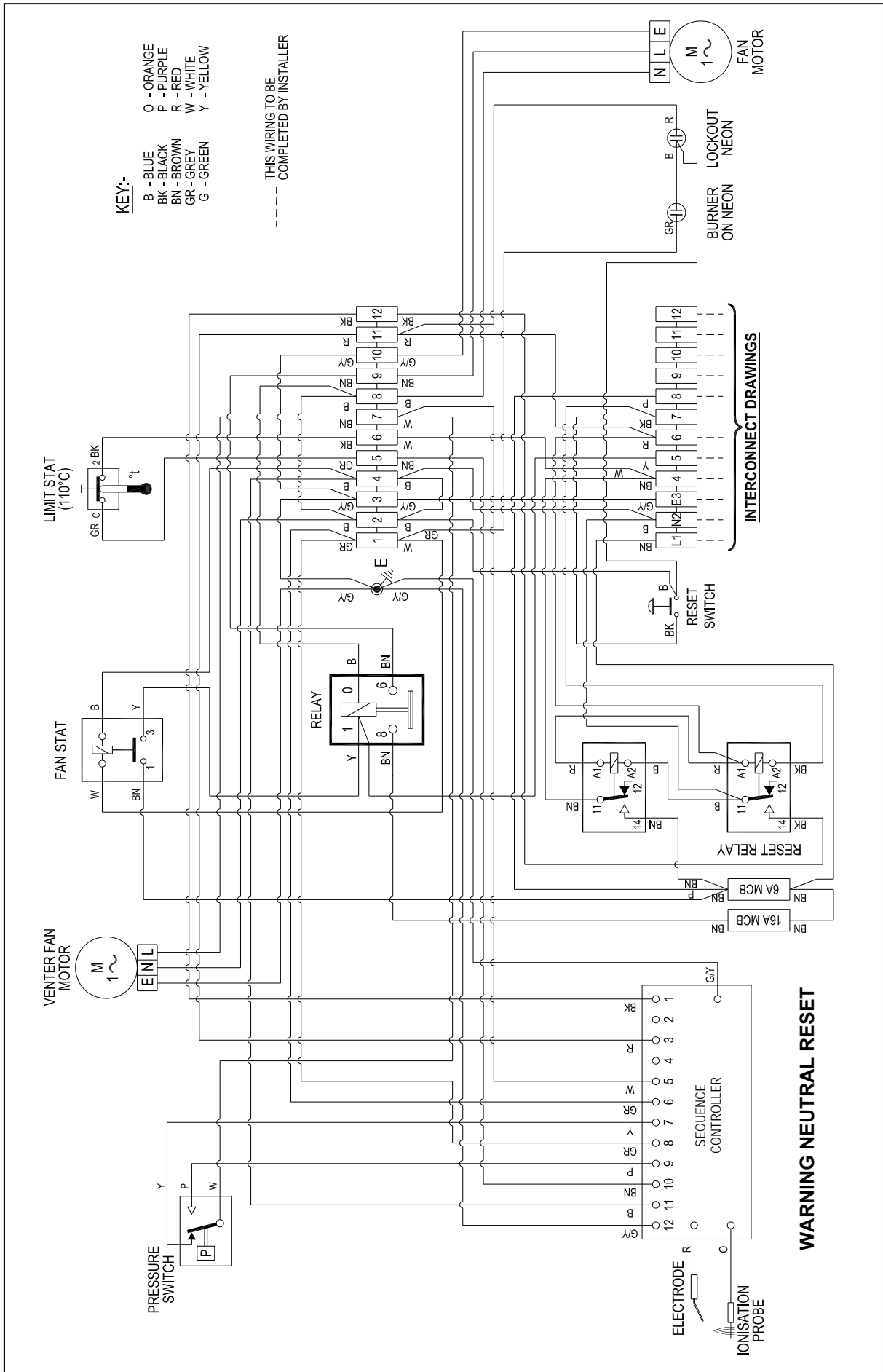

Wiring Diagram 33-68-004 VRA 72-145 Auto ignition On/Off

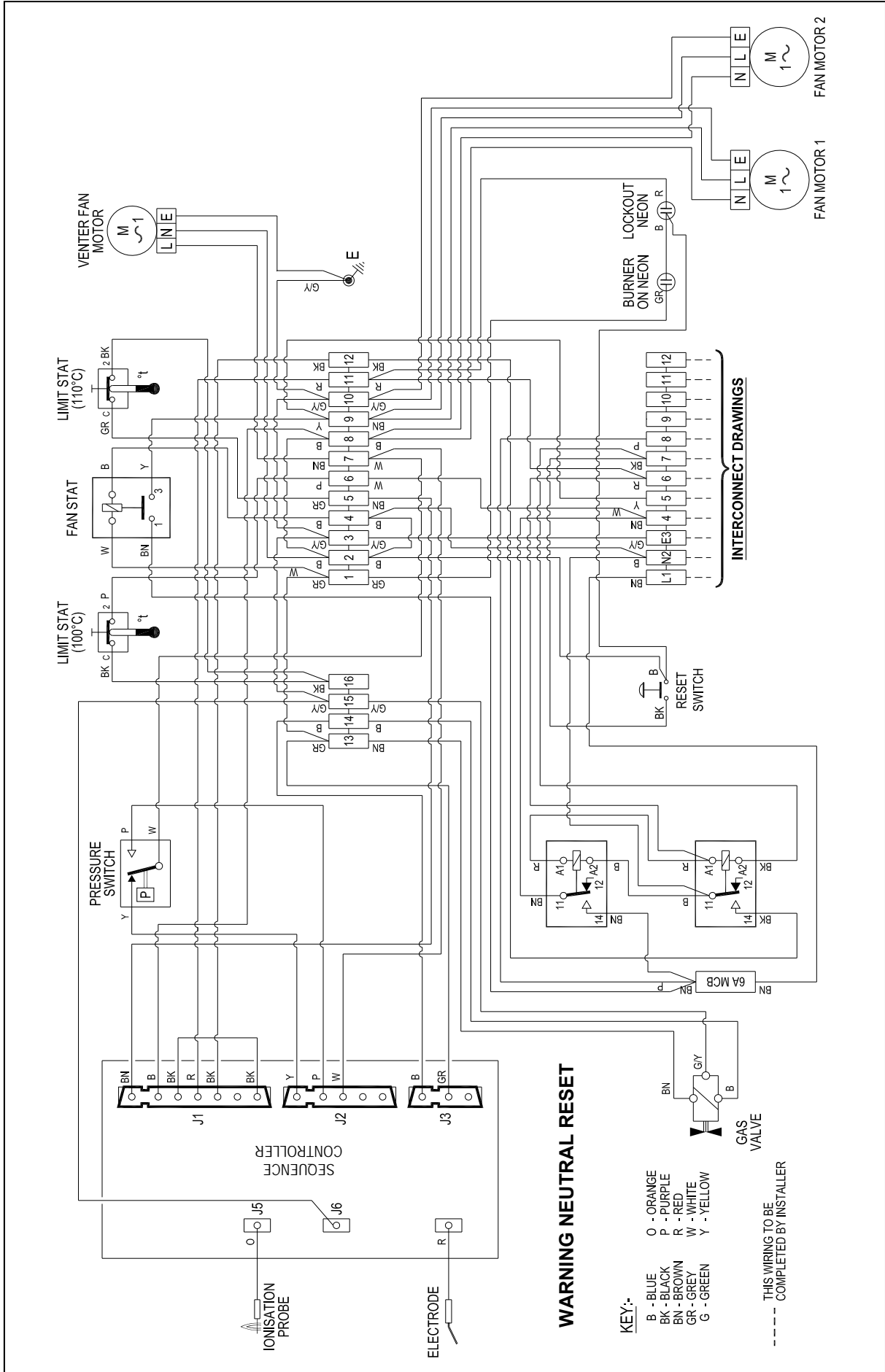

Wiring Diagram 33-68-013 VRC 72-95 VRE120-145 Auto ignition On/Off

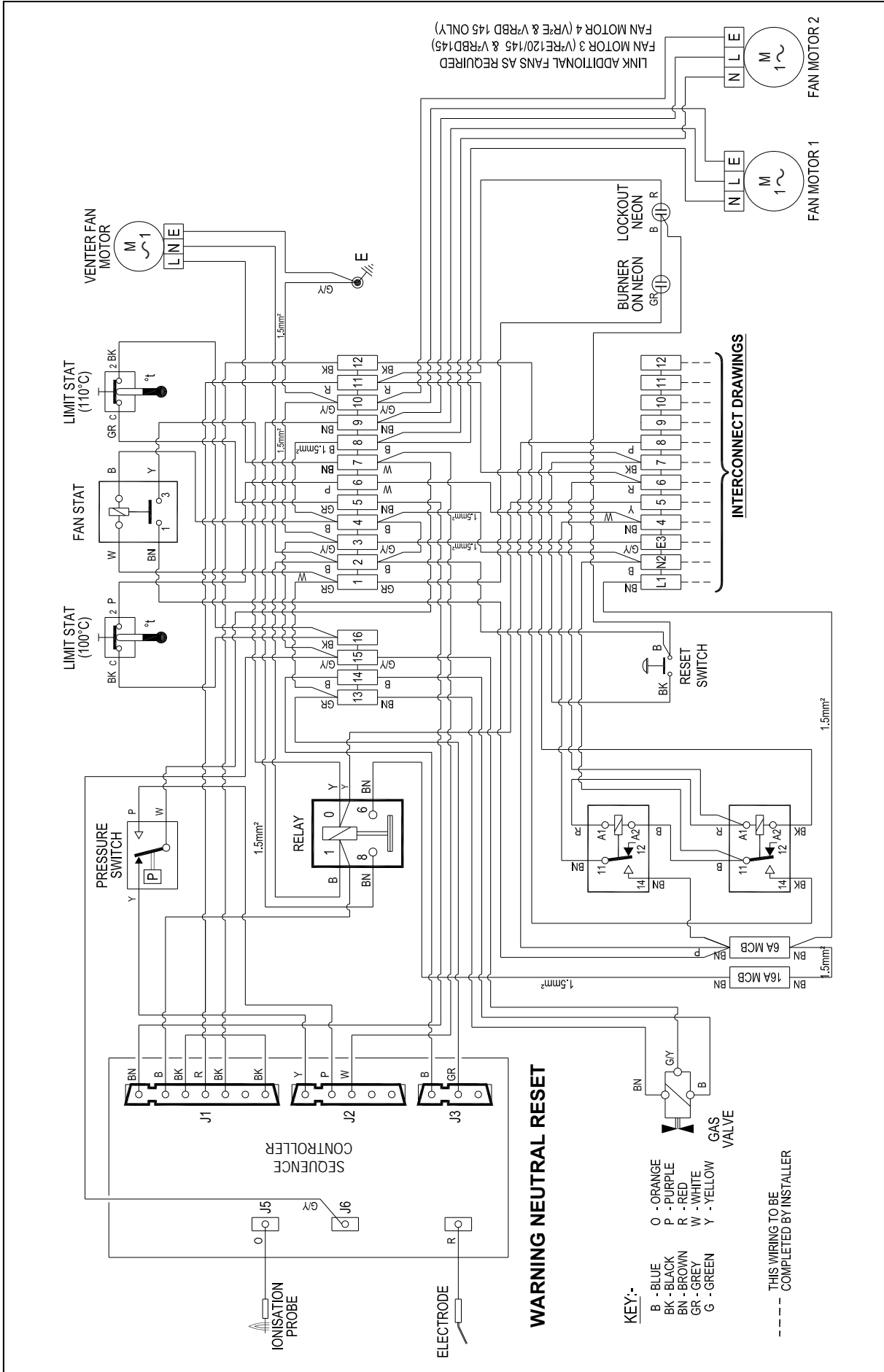

Wiring Diagram 33-68-016 VRC 72-145 3 Phase Auto ignition On/Off

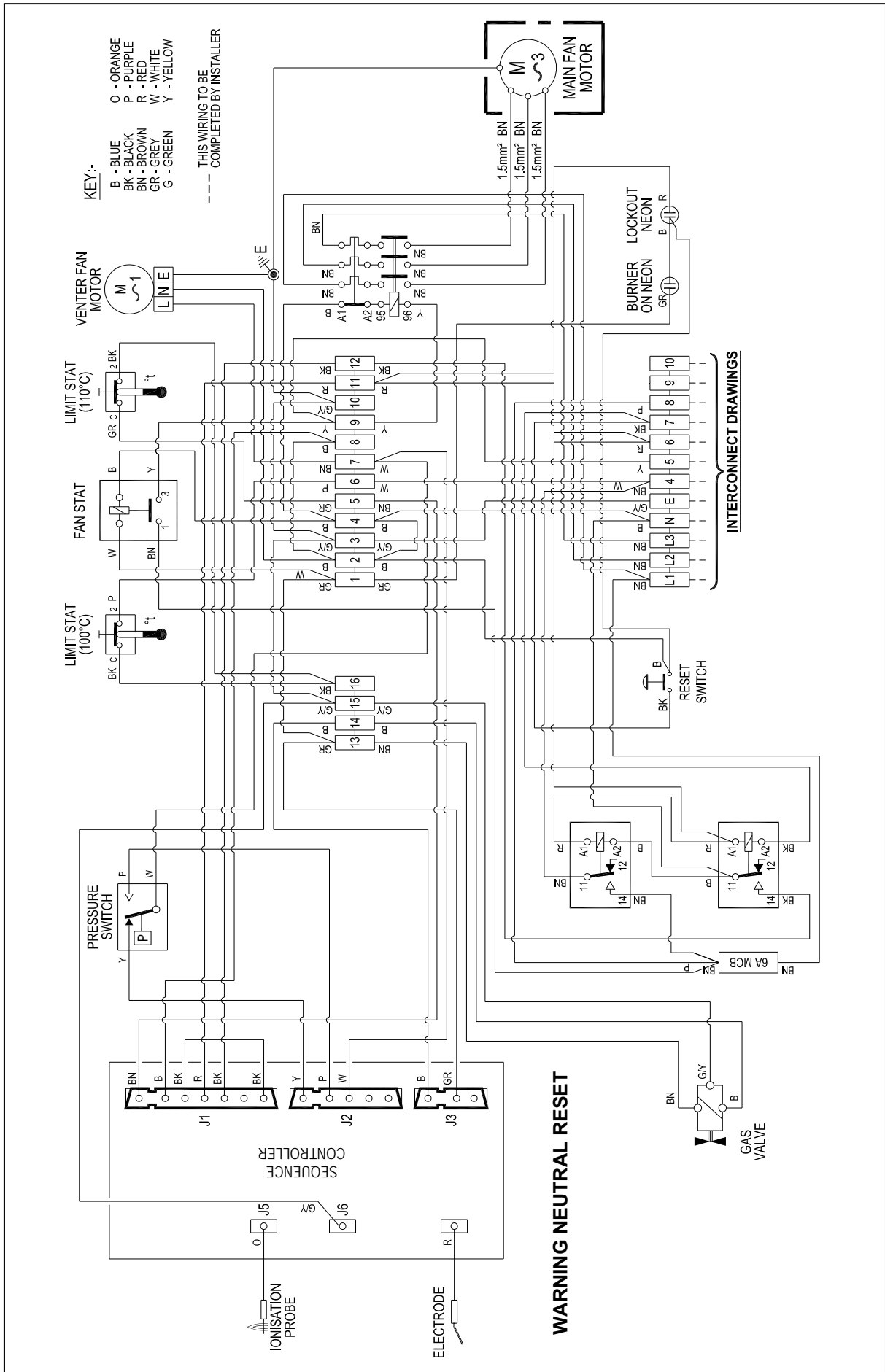

Wiring Diagram 33-68-002 VRA 12-60 VRC 12-30 Auto ignition Hi/Low

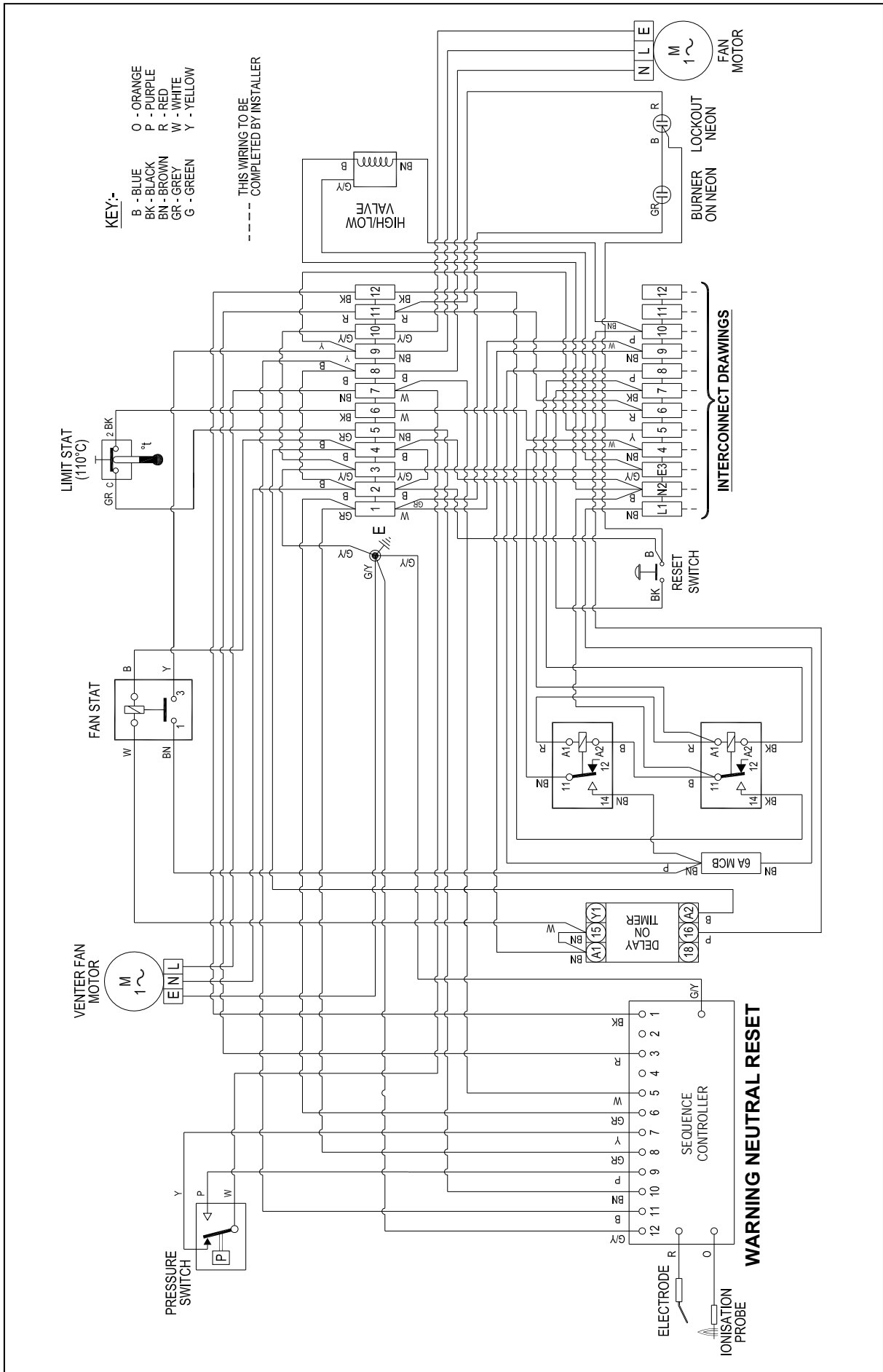

Wiring Diagram 33-68-008 VRC 42 Auto ignition Hi/Low

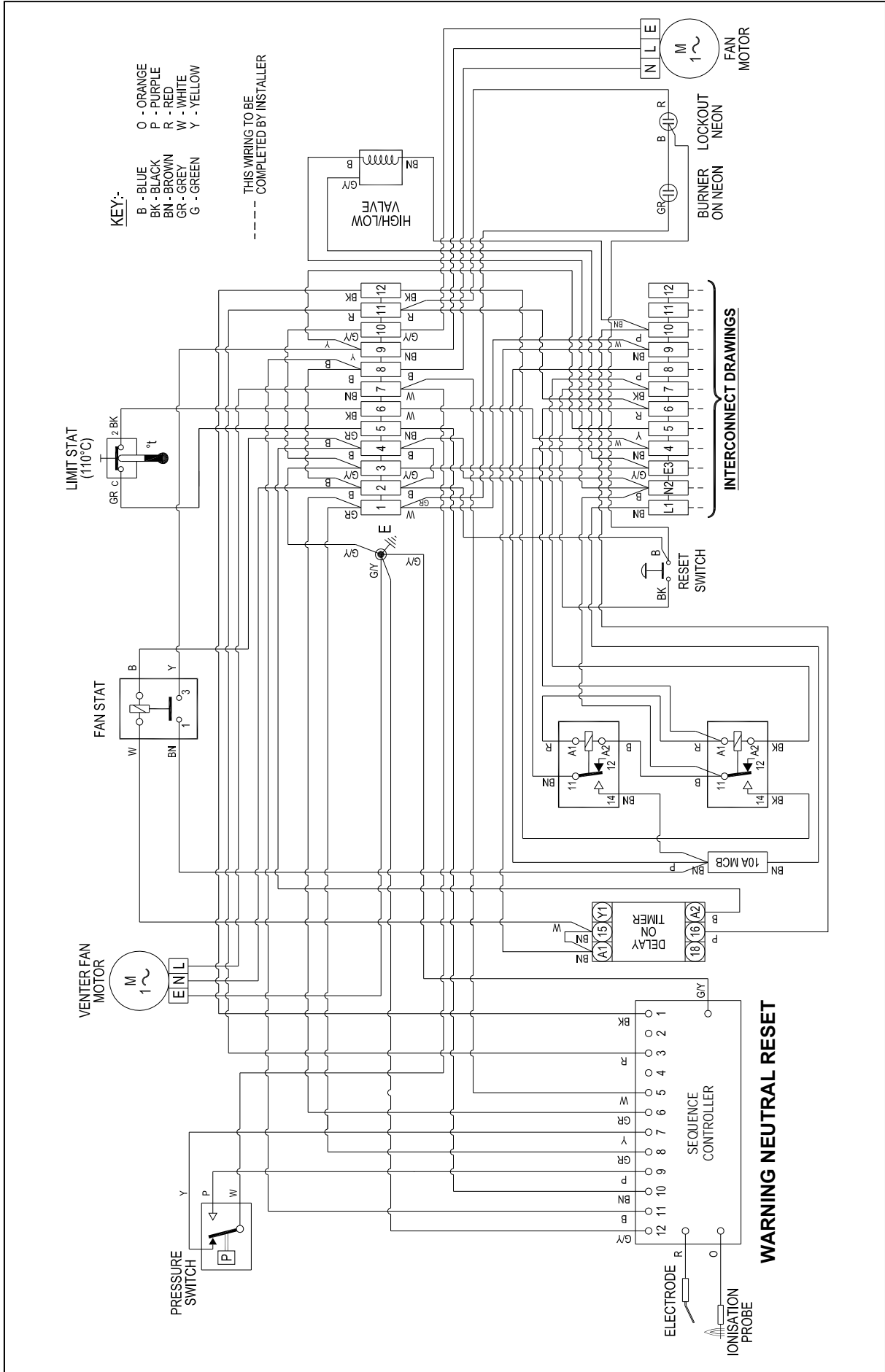

Wiring Diagram 33-68-011 VRC 50-60 Auto ignition Hi/Low

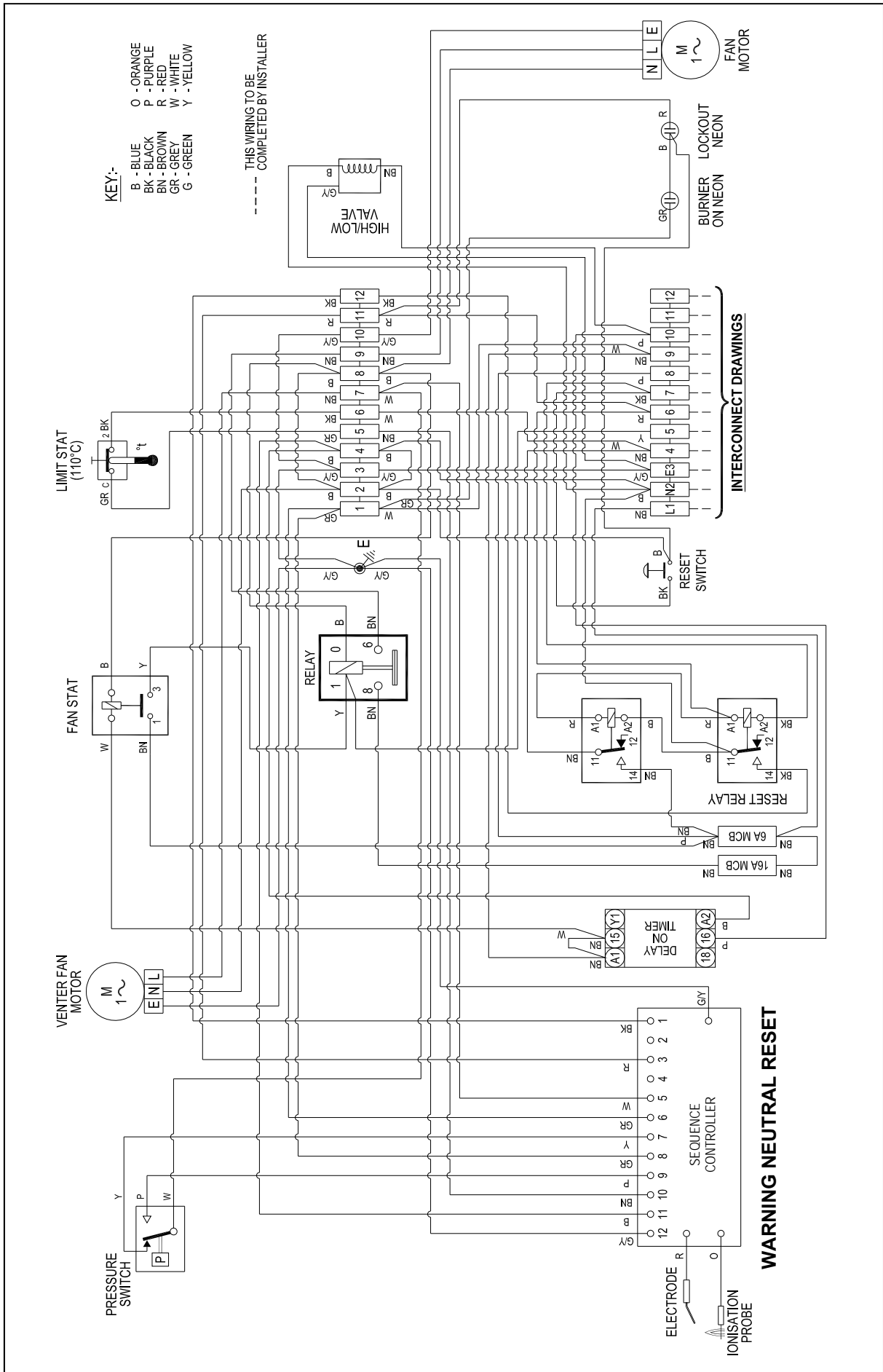

Wiring Diagram 33-68-005 VRA 72-145 Auto ignition Hi/Low

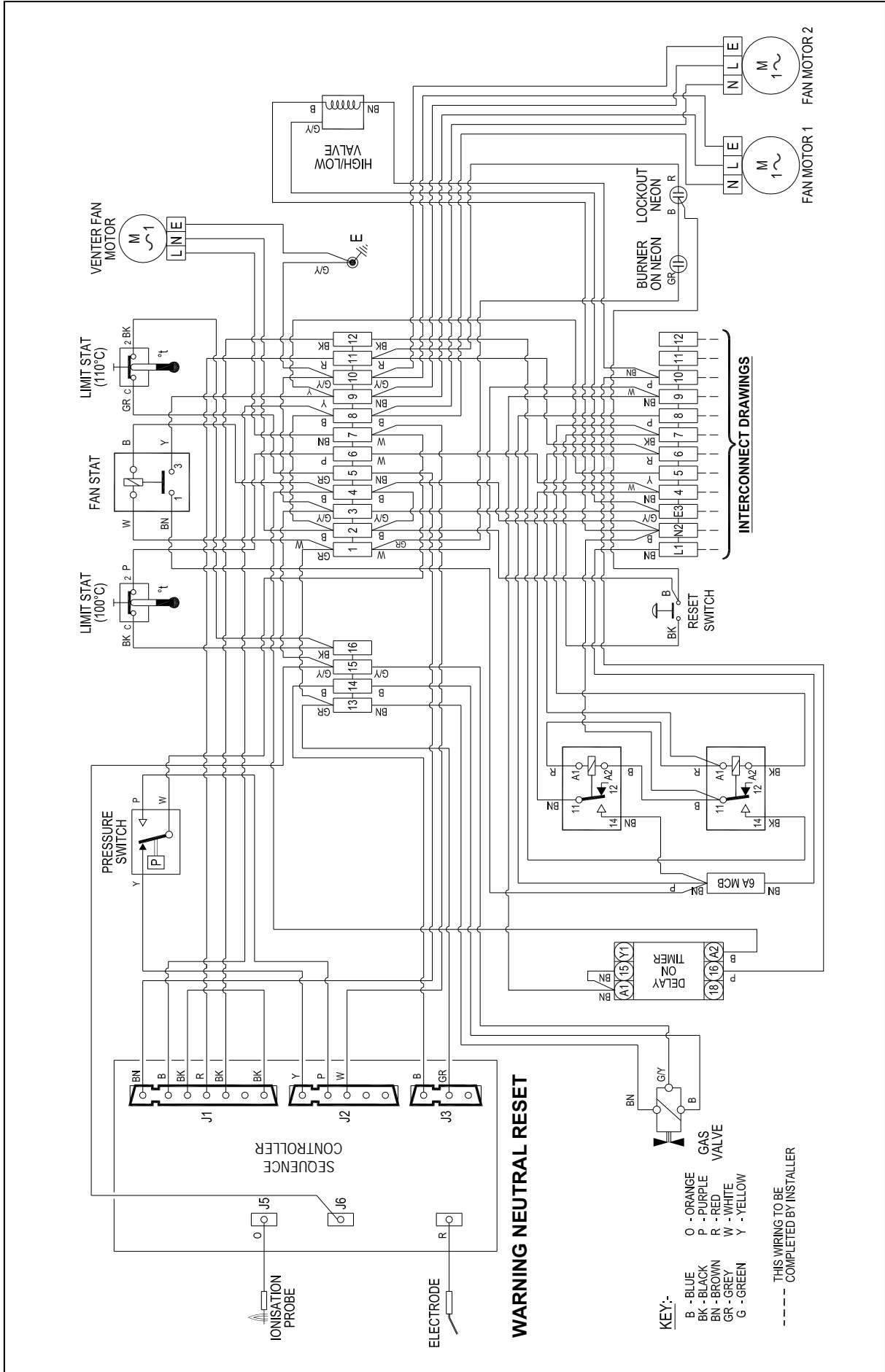

Wiring Diagram 33-68-014 VRC 72-95 VRE 120-145 Auto ignition Hi/Low

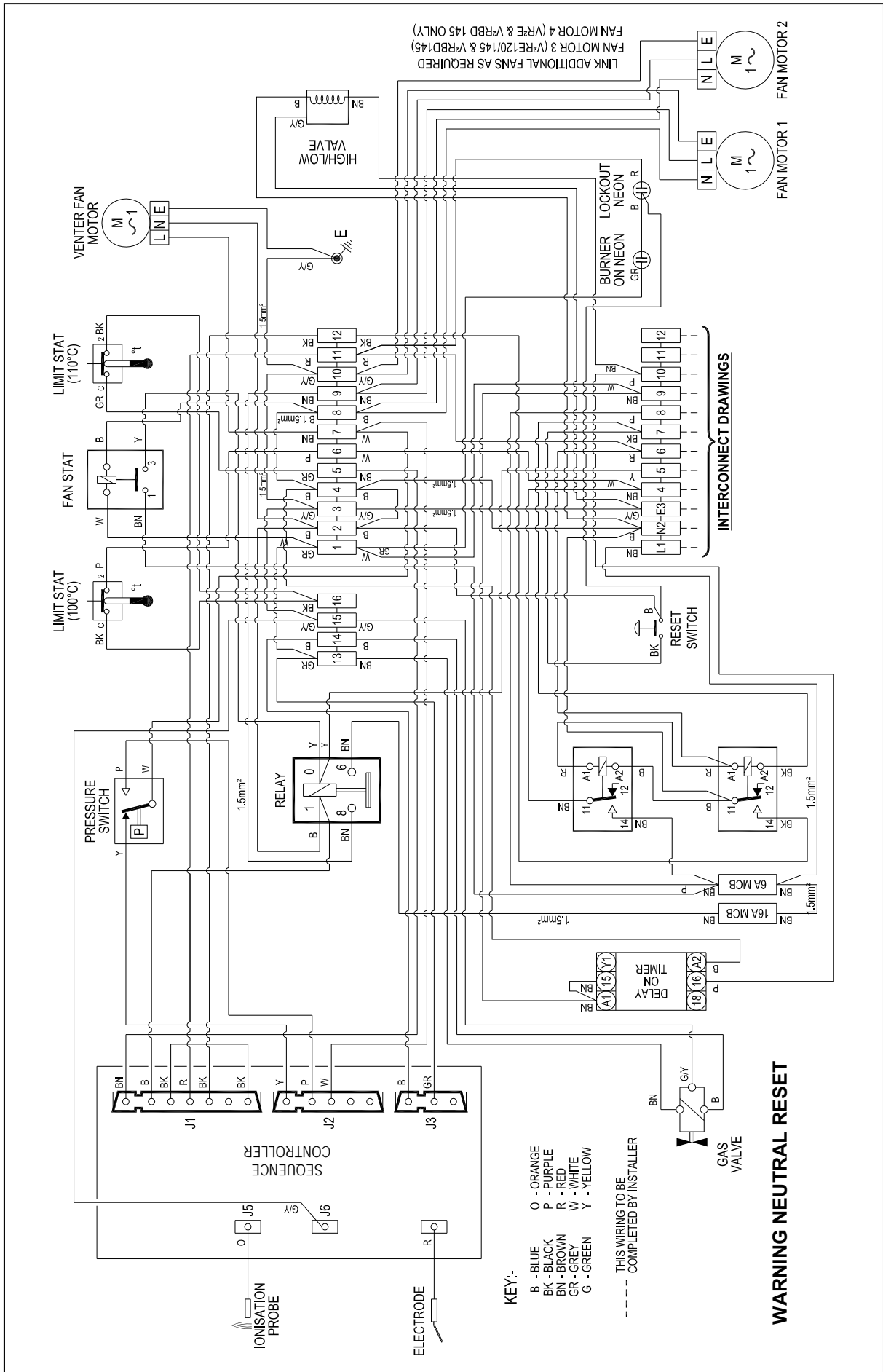

Wiring Diagram 33-68-017 VRC 72-145 3 Phase Auto ignition Hi/Low

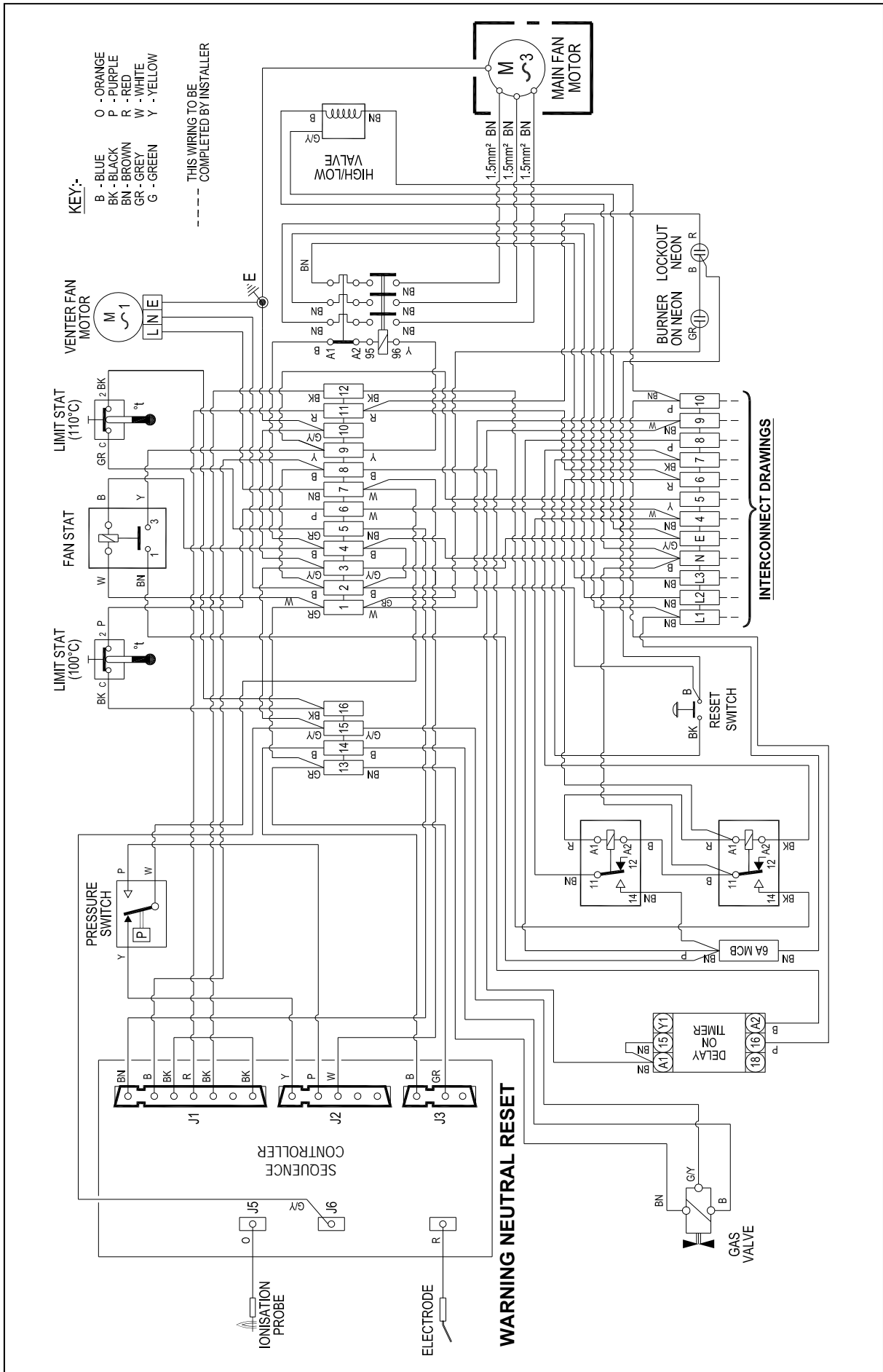

Wiring Diagram 33-68-003 VRA 12-60 VRC 12-30 Auto Ignition Modulation

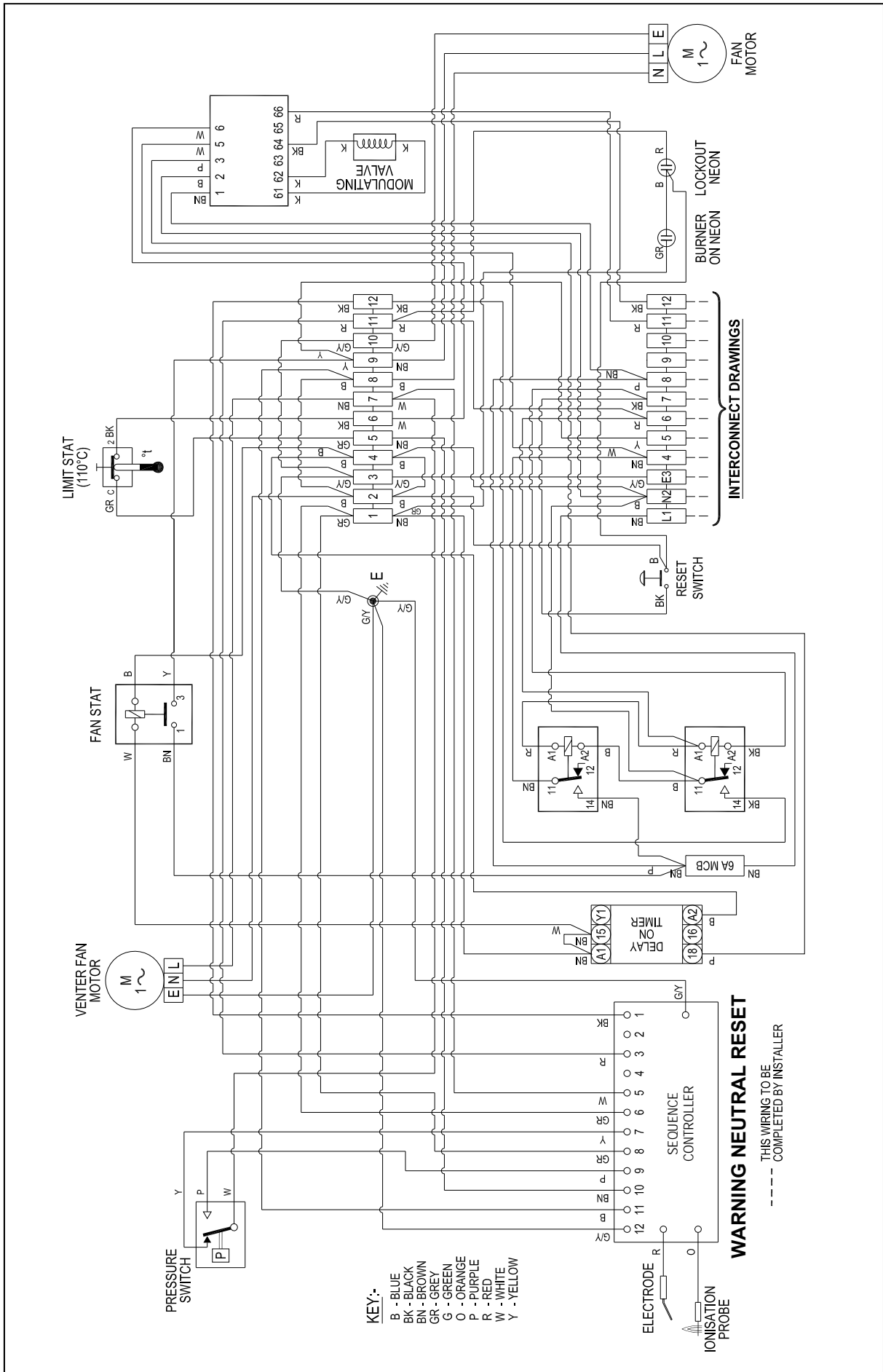

Wiring Diagram 33-68-009 VRC 42 Auto Ignition Modulation

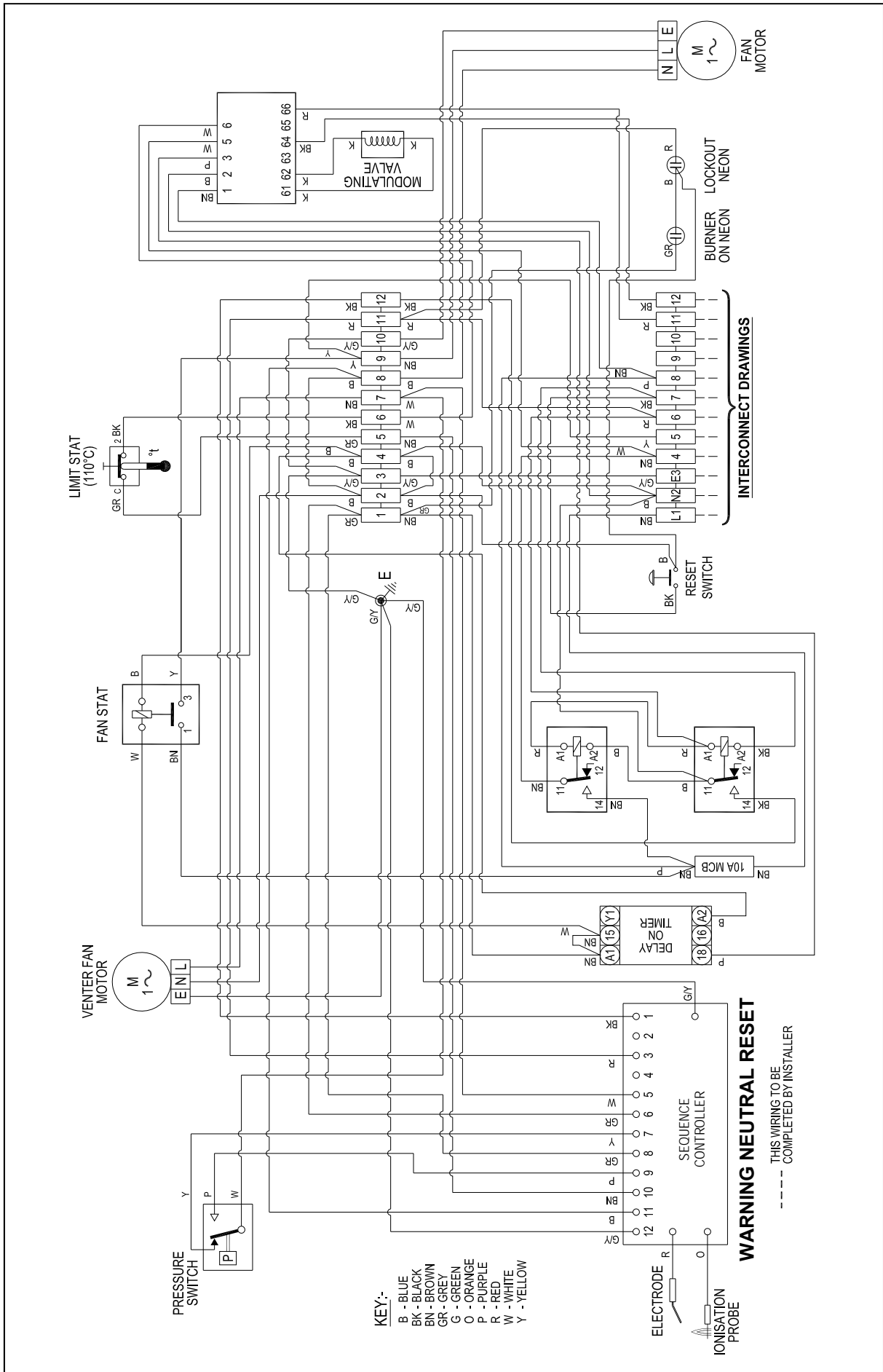

Wiring Diagram 33-68-012 VRC 50-60 Auto Ignition Modulation

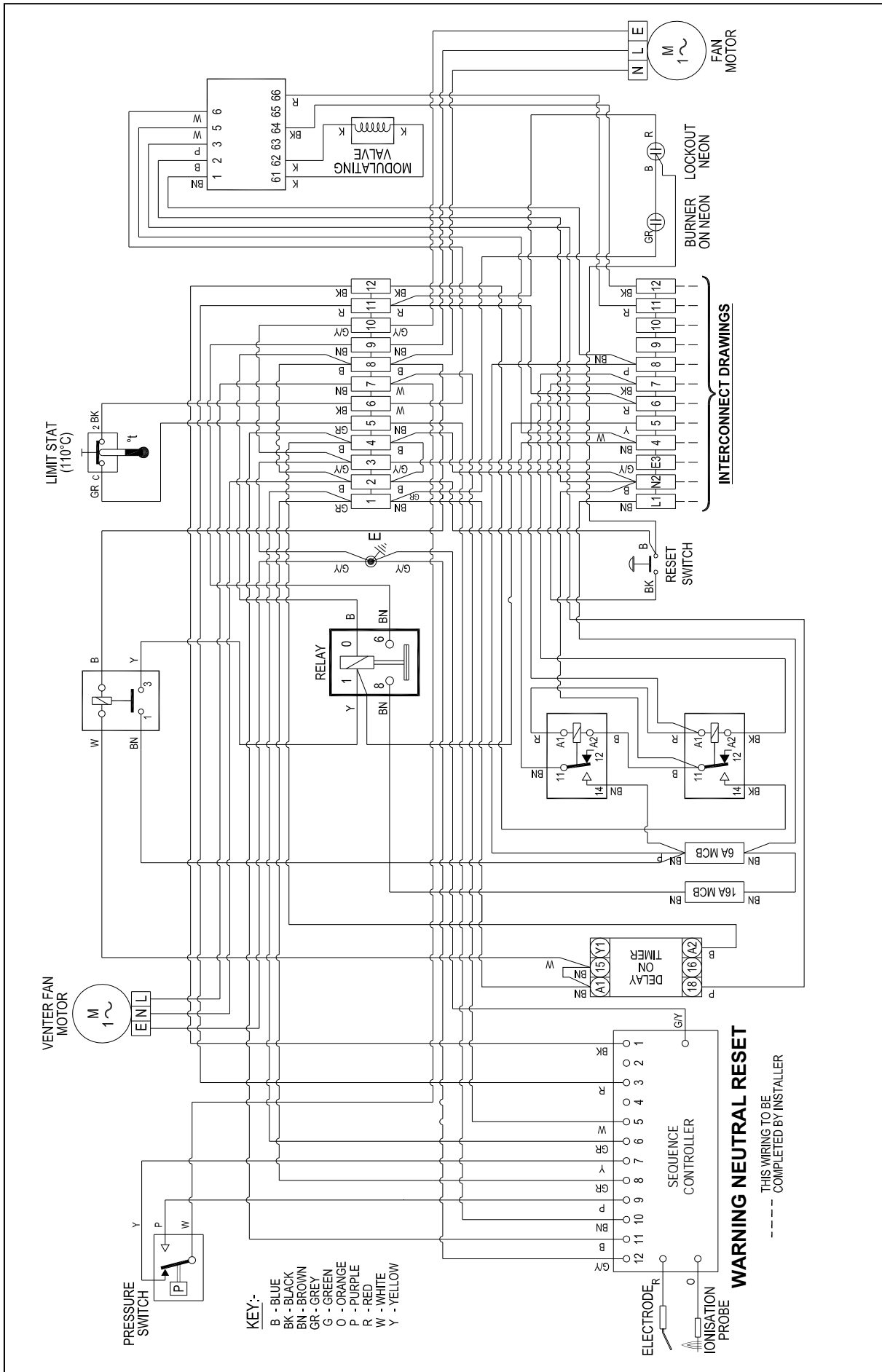

Wiring Diagram 33-68-006 VRA 72-145 Auto Ignition Modulation

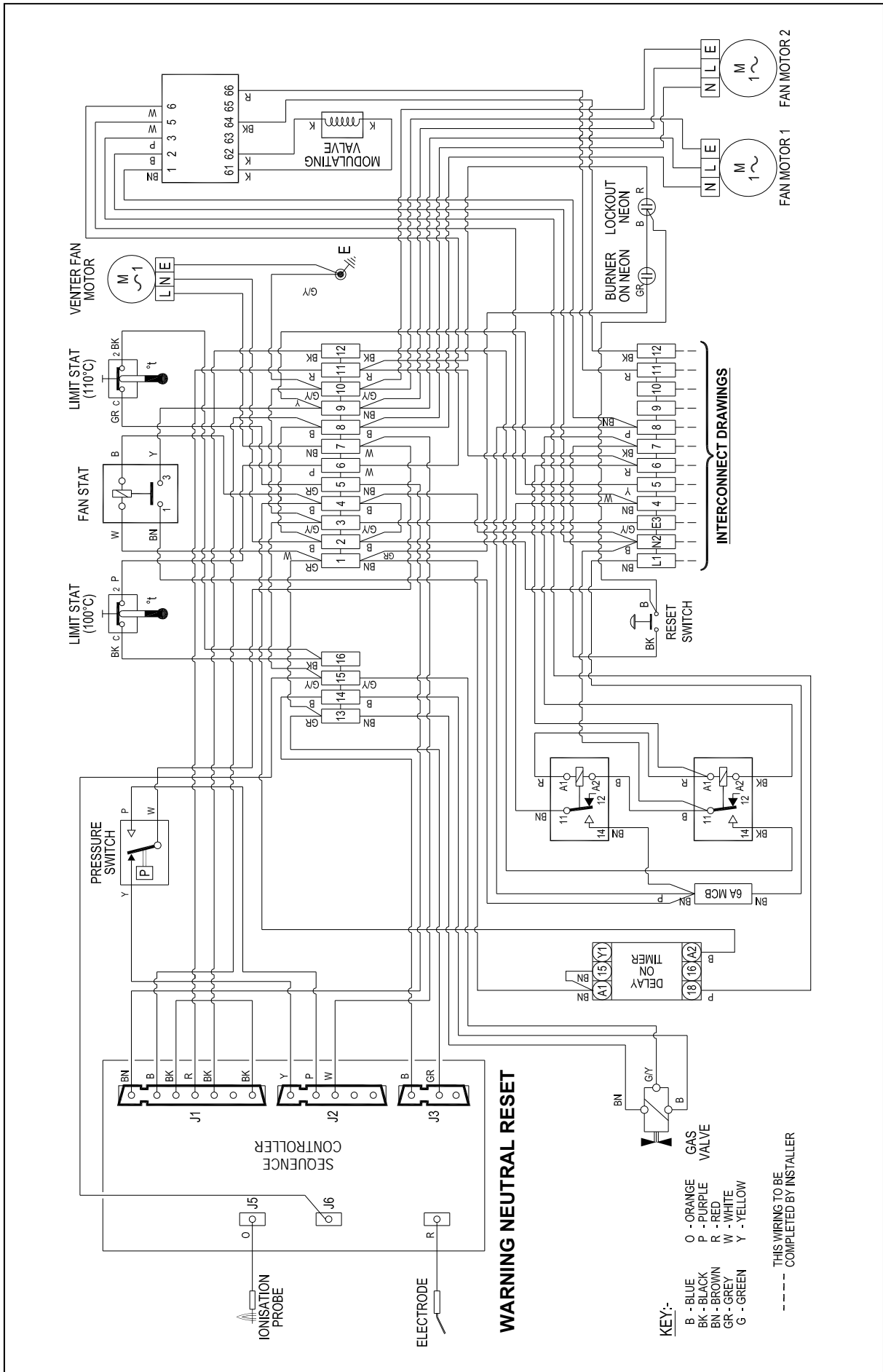

Wiring Diagram 33-68-015 VRC 72-95 VRE 120-145 Auto ignition Modulation

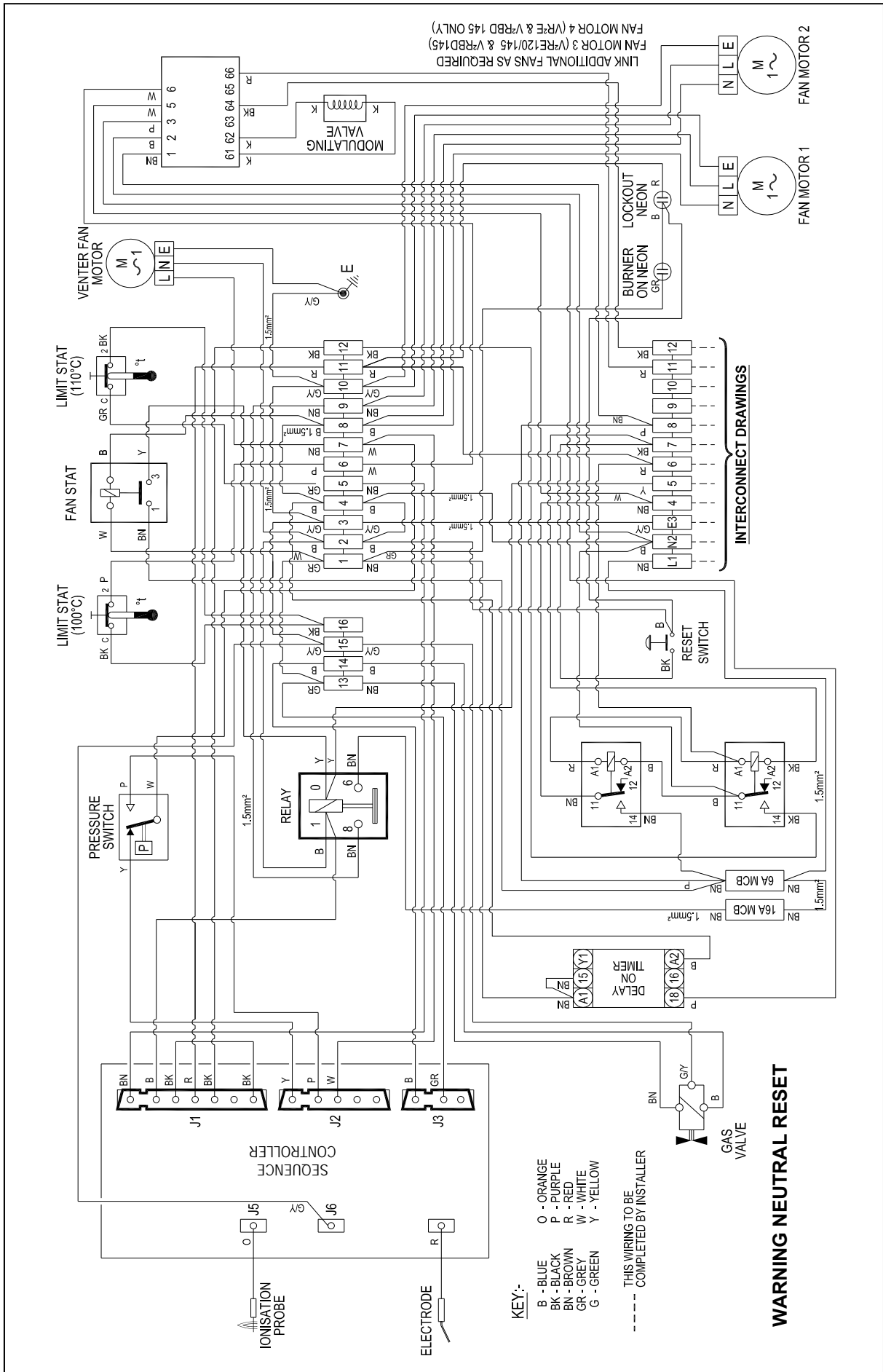

Wiring Diagram 33-68-018 VRC 72-145 3 Phase Auto ignition Modulation

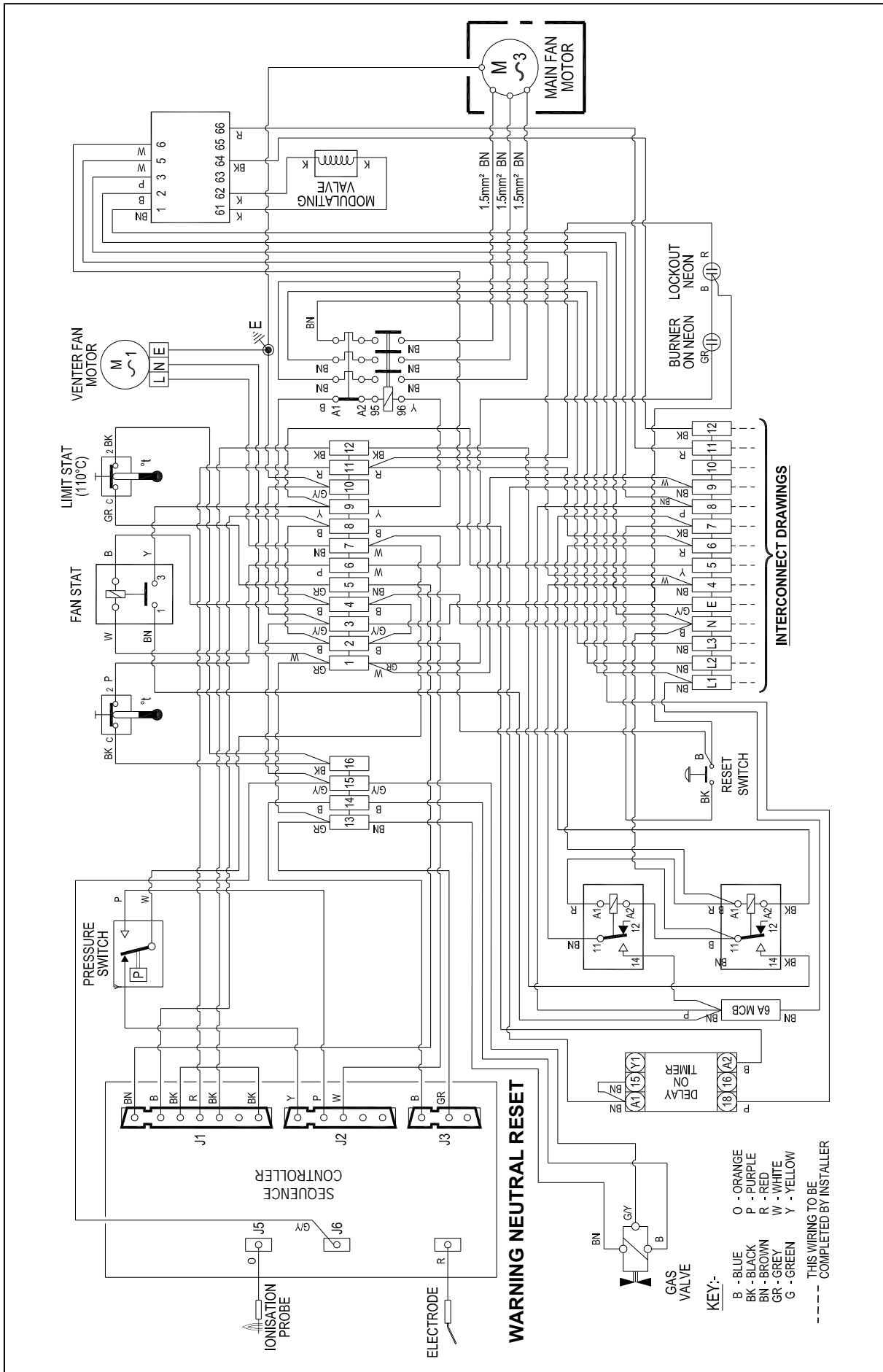

AmbiRad Group

Heating and Ventilation Solutions

Technical Support:

Tel: **01384 489 200**

Fax: **01384 489 707**

ambiradgroupsupport@tnb.com
www.ambiradgroup.co.uk

AMBIRAD AIRBLOC NORDAIRNICHE BENSON

A Thomas & Betts Company. Registered in England No. 1390934. Registered office: 27/28 East Castle Street, London.

AmbiRad UK is a registered trademark of AmbiRad Limited. Because of continuous product innovation, AmbiRad reserves the right to change product specification without due notice.