

SMARTCOM³ CONTROL PANEL & WARM AIR WIRING INTERCONNECTS.



Warnings

All external wiring **MUST** comply with the current IEE wiring regulations. These instruction **MUST** be used in conjunction with the SmartCom user manual and the appropriate heater manual.











Visit our Support Database
at www.s-i-d.co.uk

Part No. 704005



INDEX

	Diagram Number(s)			
	Heater type	Single Stage	Two Stage	Modulation
				
	UESA (all versions) UDSA-3* (025-100) <i>*from Jan14</i> UDSA-4** (055-085) <i>**from Sept 15</i> VRA-3*** (12-145) <i>***after s/no.154501956</i>	1	2	3
	UDSA UDSA-2 UDSA-3 (008-020) UDSA-3* (025-100) <i>*prior to Jan14</i> VRA-3** (12-145) <i>**prior to s/no.154501956</i> UPA LCSA	4	5	6
	SDH SHH	7	8	9
	OUHA	10	11	-
	ULSA	-	-	18
	ST-2 series UC series c/w Autospark ignition	12	13	14
	UC series c/w Thermoelectric (P/Pilot)	15	16	17

1 Single Stage (on/off) Heaters with BMBC Autospark ignition to remote SmartCom³ SZ.

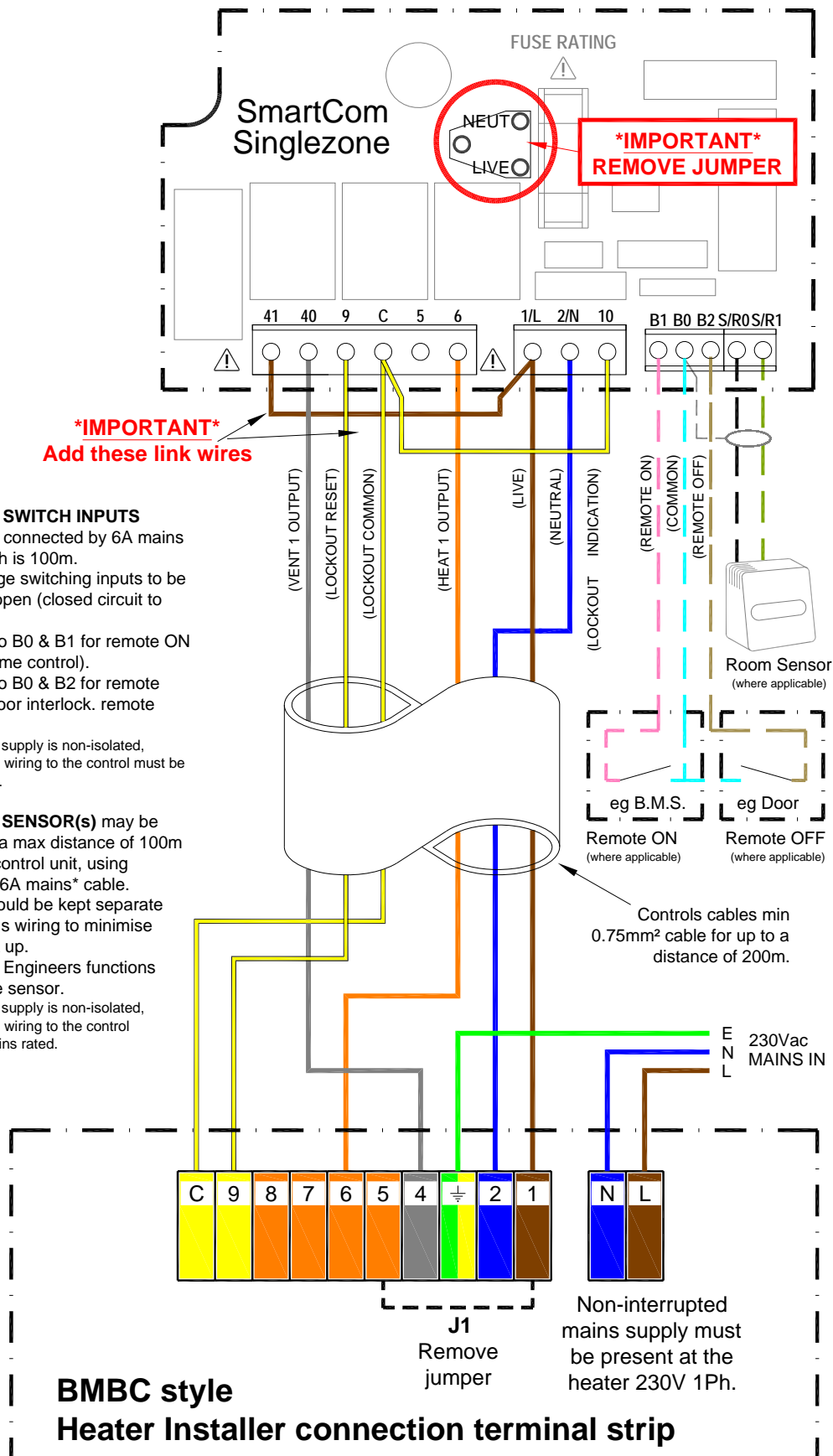

2 Two Stage (hi/low) Heaters with BMBC Autospark ignition to remote SmartCom³ MZ (or Network).

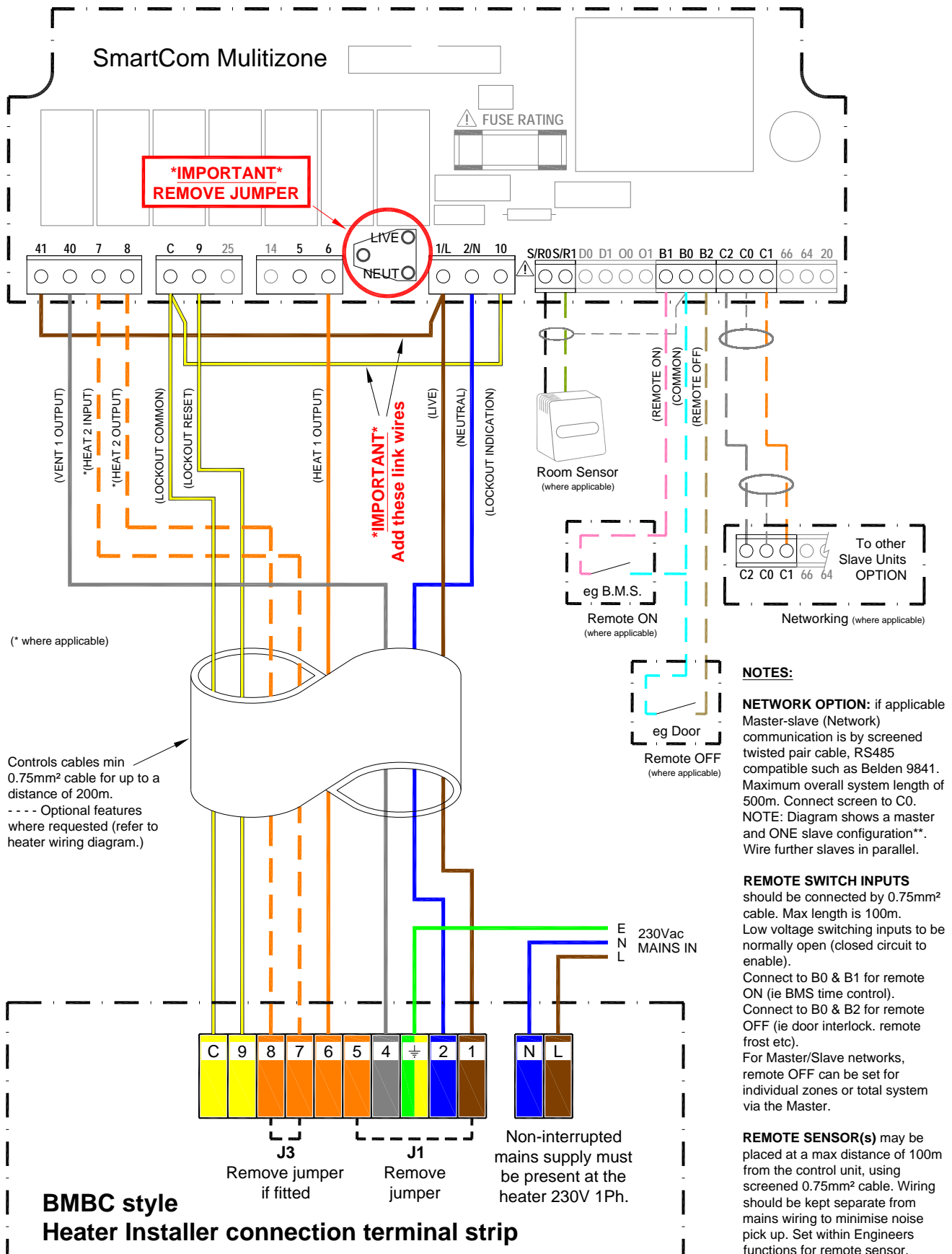

3 Modulation Heaters with BMBC Autospark ignition to remote SmartCom³ MZ (or Network).

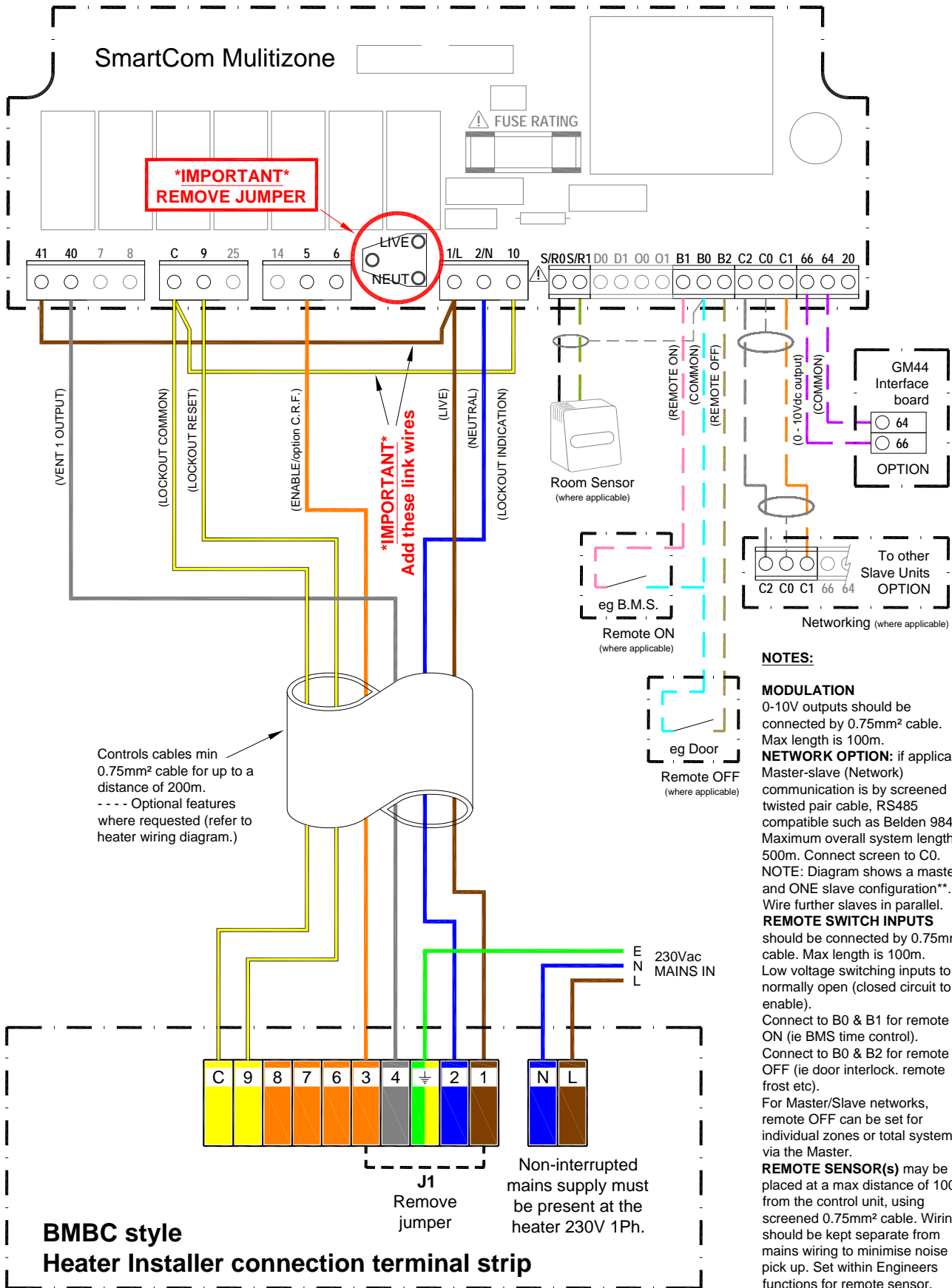

4 Single Stage (on/off) Heaters with Autospark ignition to remote SmartCom³ SZ.

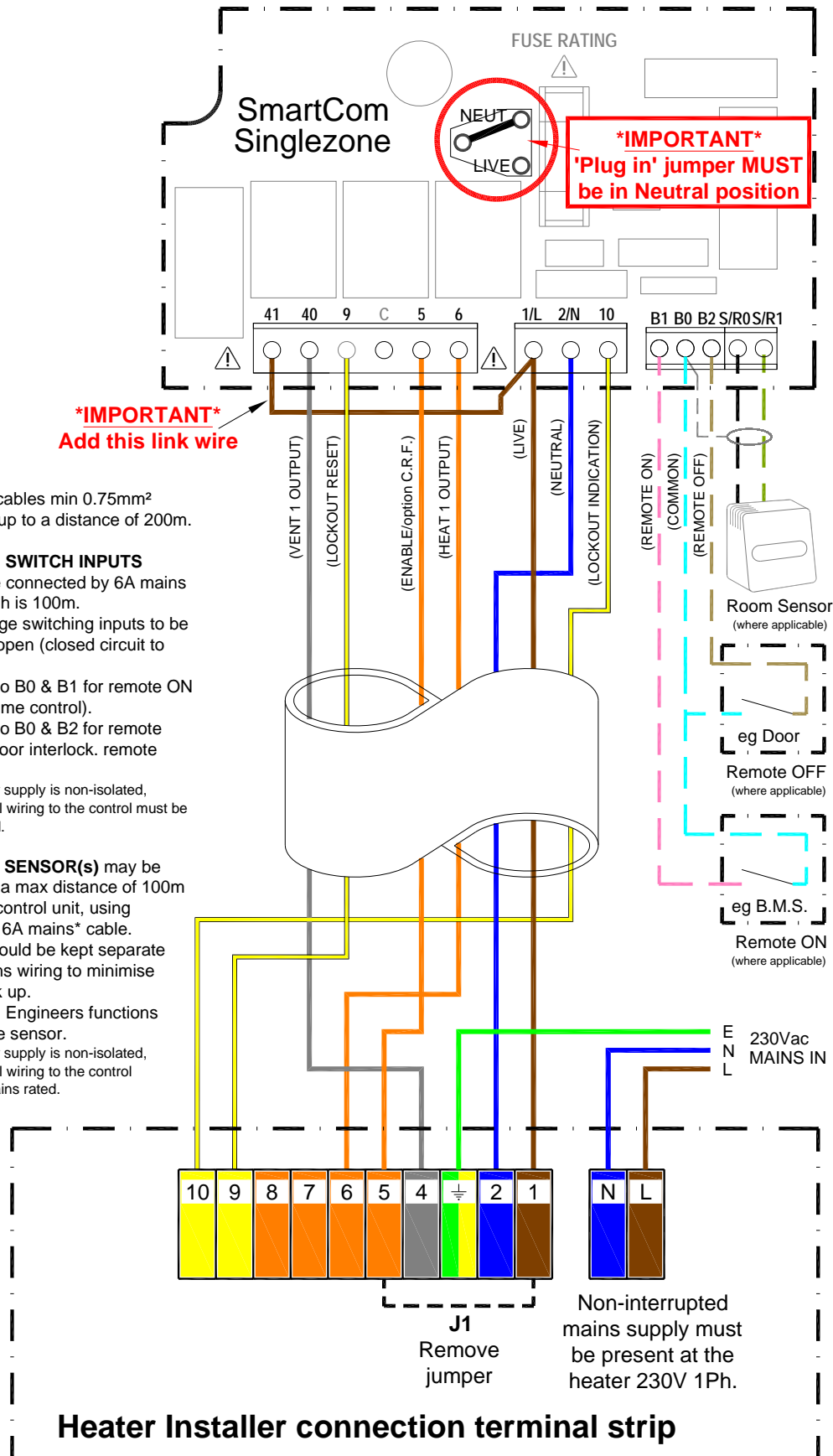

5 Two Stage (hi/low) Heaters with Autospark ignition to remote SmartCom³ MZ (or Network).

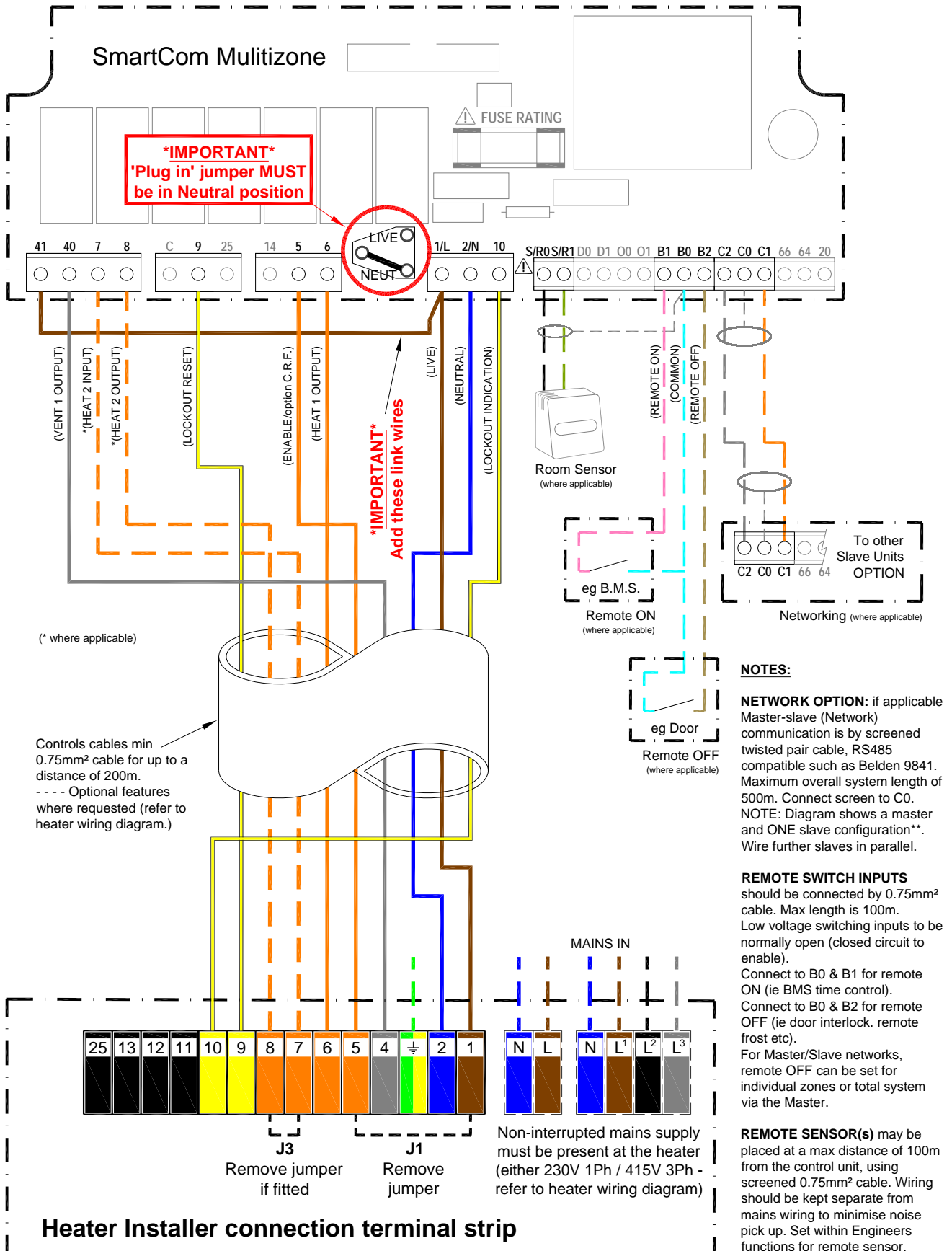

6 Modulation Heaters with Autospark ignition to remote SmartCom³ MZ (or Network).

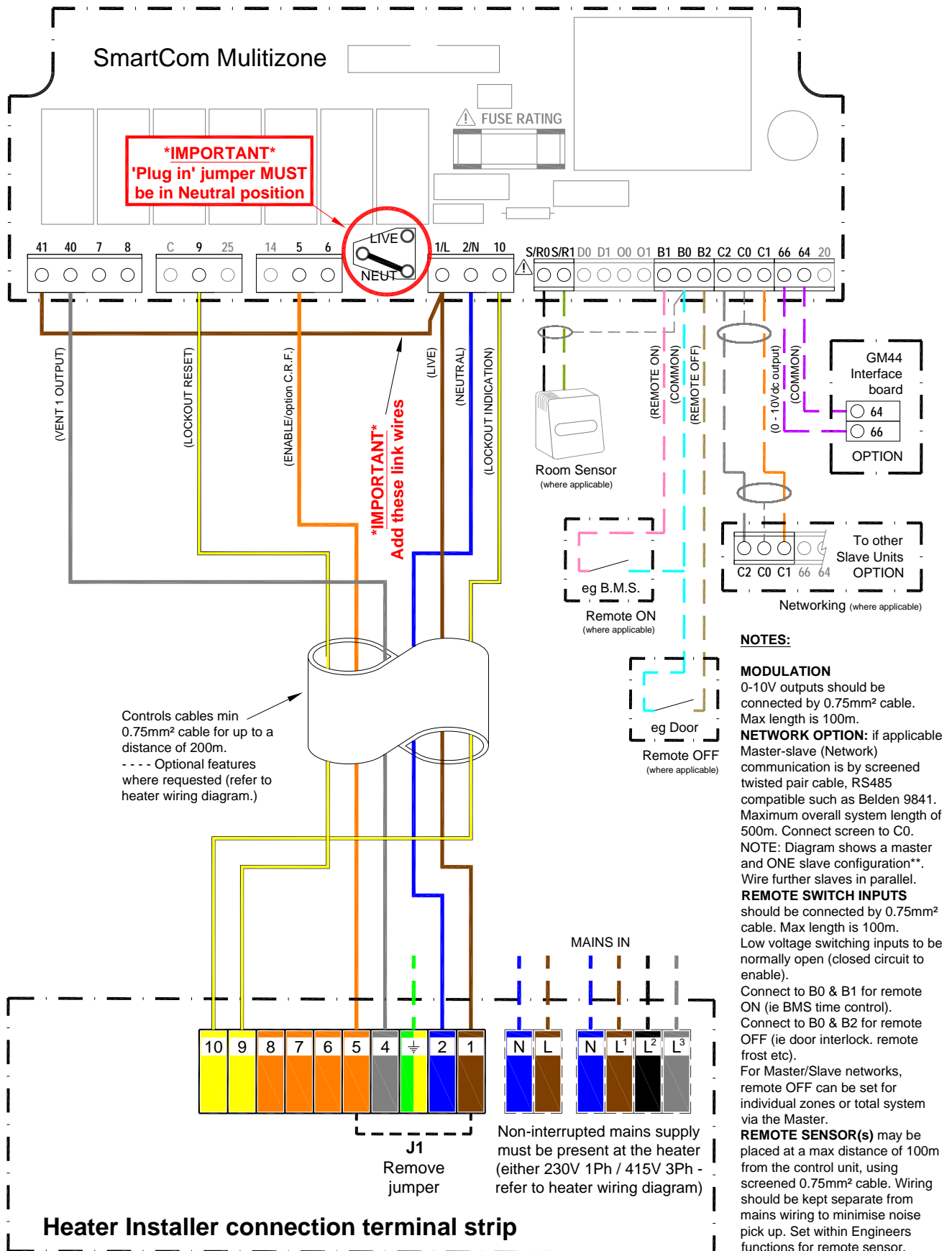

7 Single Stage (on/off) SDH/SHH Heaters, Autospark ignition to remote SmartCom³ SZ.

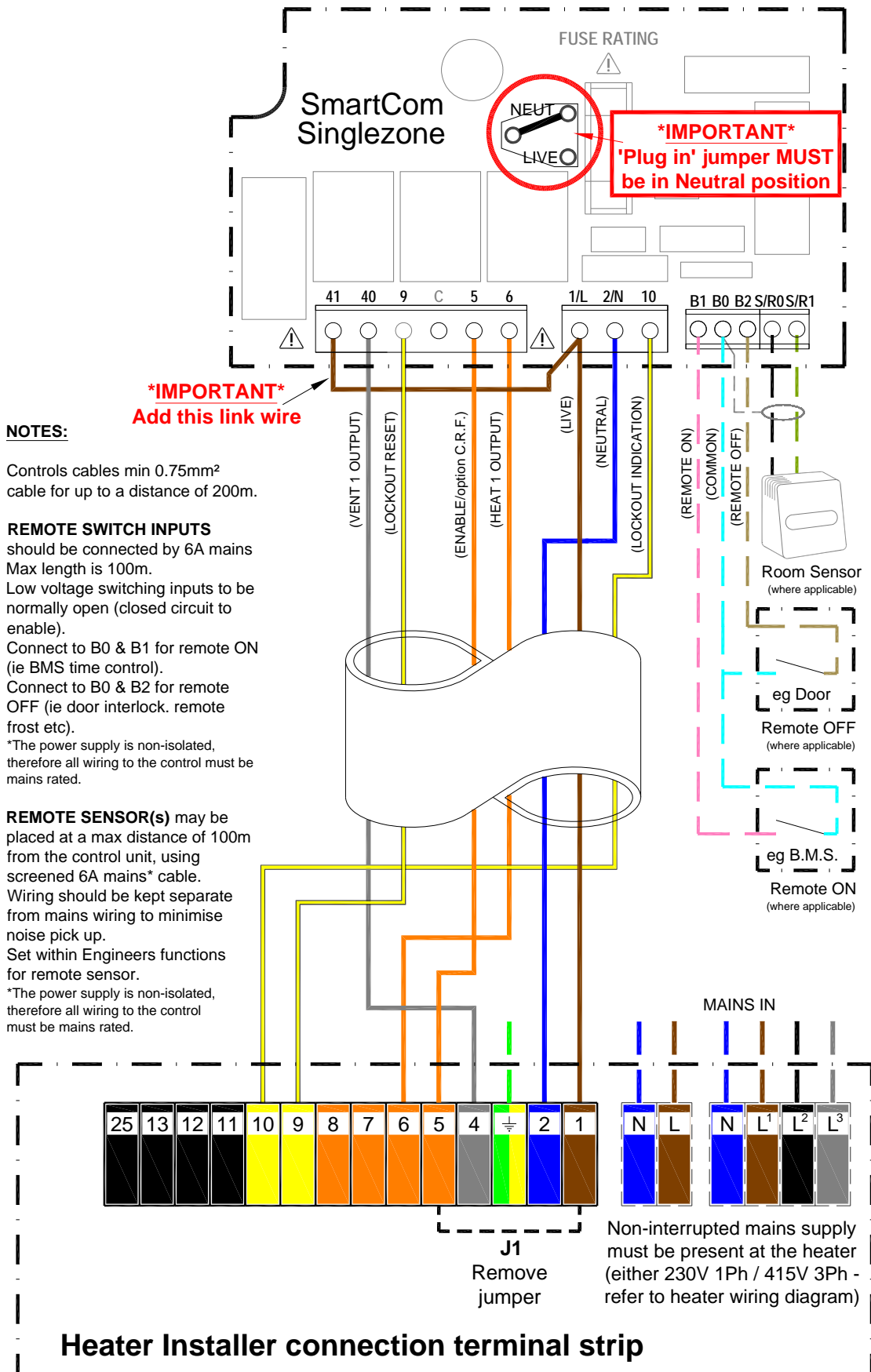

8 Two Stage (hi/low) SDH/SHH Heaters, Autospark ignition to remote SmartCom³ MZ (or Network).

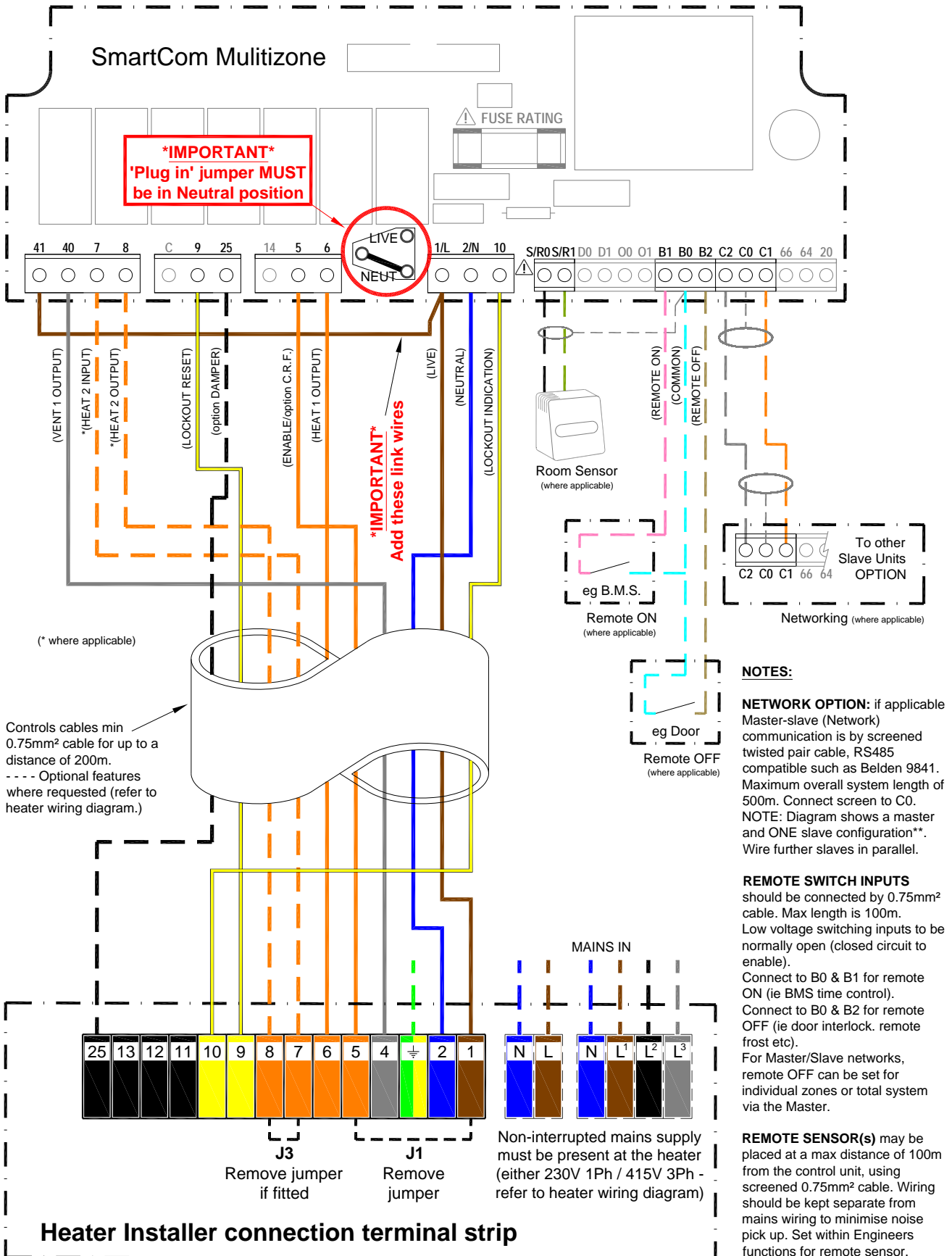

9 Modulation SDH/SHH Heaters, Autospark ignition to remote SmartCom³ MZ (or Network).

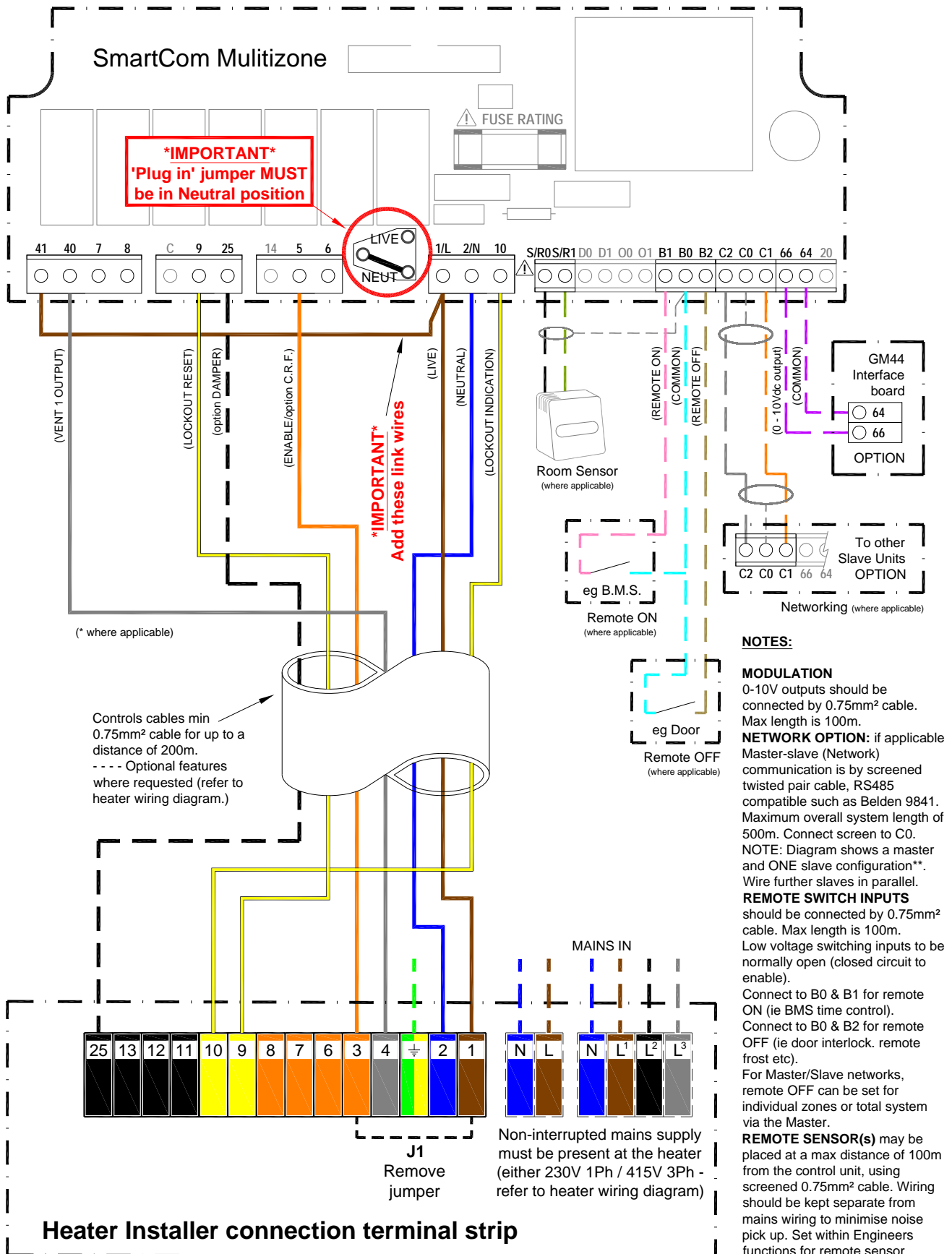

10 Single Stage (on/off) OUHA Heaters with Autospark to remote SmartCom³ SZ.

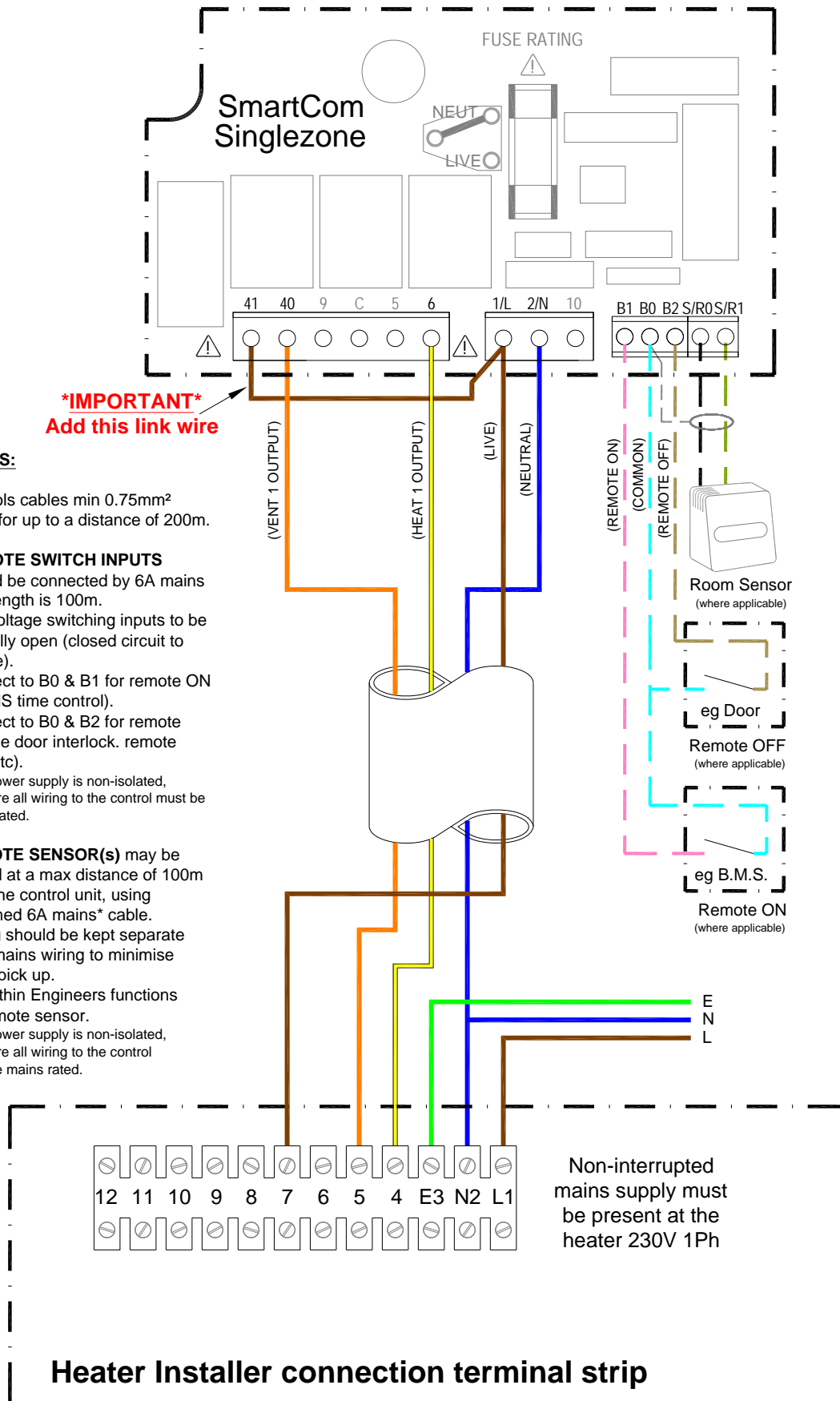

11 Two Stage (hi/low) OUHA Heaters with Autospark Ignition to remote SmartCom³ MZ (or Network).

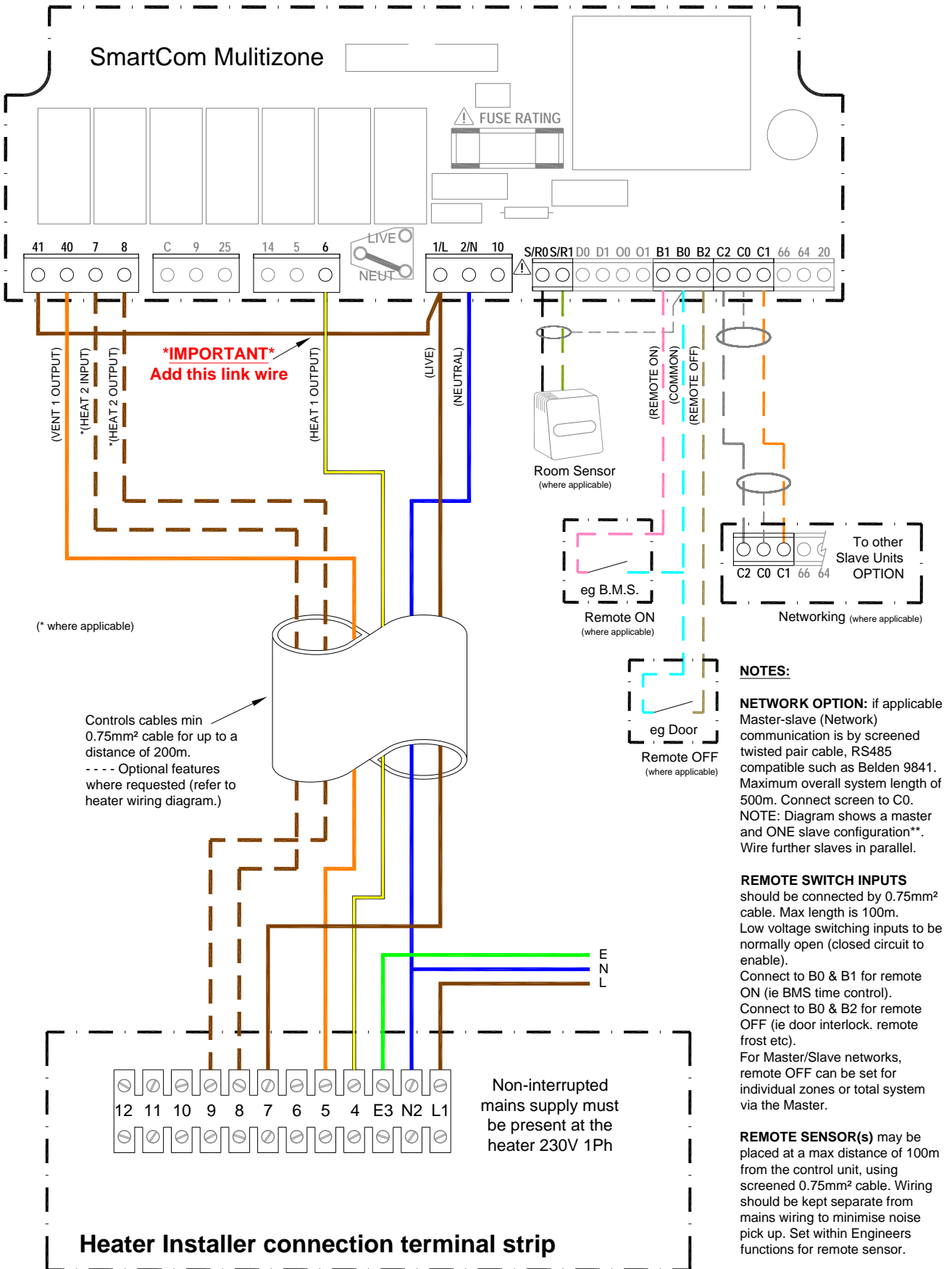

12 Single Stage (on/off) ST Heaters with Autospark to remote SmartCom³ SZ.

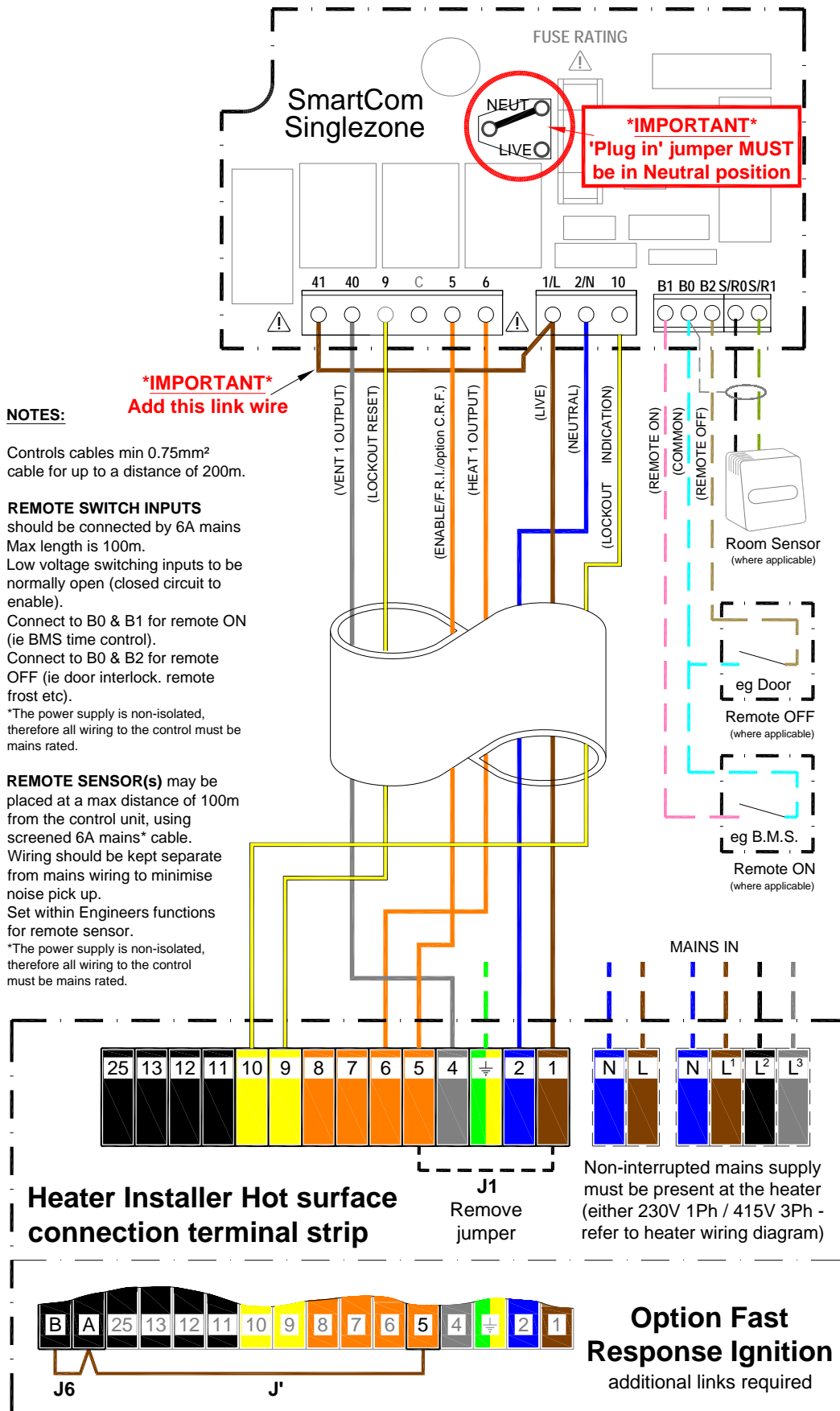

NOTES:

Controls cables min 0.75mm² cable for up to a distance of 200m.

REMOTE SWITCH INPUTS

should be connected by 6A mains Max length is 100m. Low voltage switching inputs to be normally open (closed circuit to enable). Connect to B0 & B1 for remote ON (ie BMS time control). Connect to B0 & B2 for remote OFF (ie door interlock. remote frost etc). *The power supply is non-isolated, therefore all wiring to the control must be mains rated.

REMOTE SENSOR(s) may be placed at a max distance of 100m from the control unit, using screened 6A mains* cable. Wiring should be kept separate from mains wiring to minimise noise pick up. Set within Engineers functions for remote sensor. *The power supply is non-isolated, therefore all wiring to the control must be mains rated.

Heater Installer Hot surface connection terminal strip

J1 Remove jumper

Non-interrupted mains supply must be present at the heater (either 230V 1Ph / 415V 3Ph - refer to heater wiring diagram)

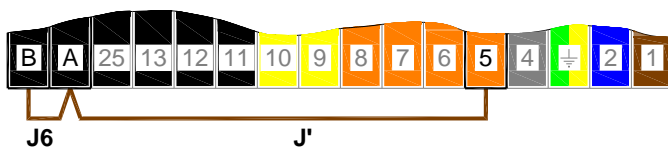

Option Fast Response Ignition
additional links required

13 Two Stage (hi/low) ST Heaters with Autospark Ignition to remote SmartCom³ MZ (or Network).

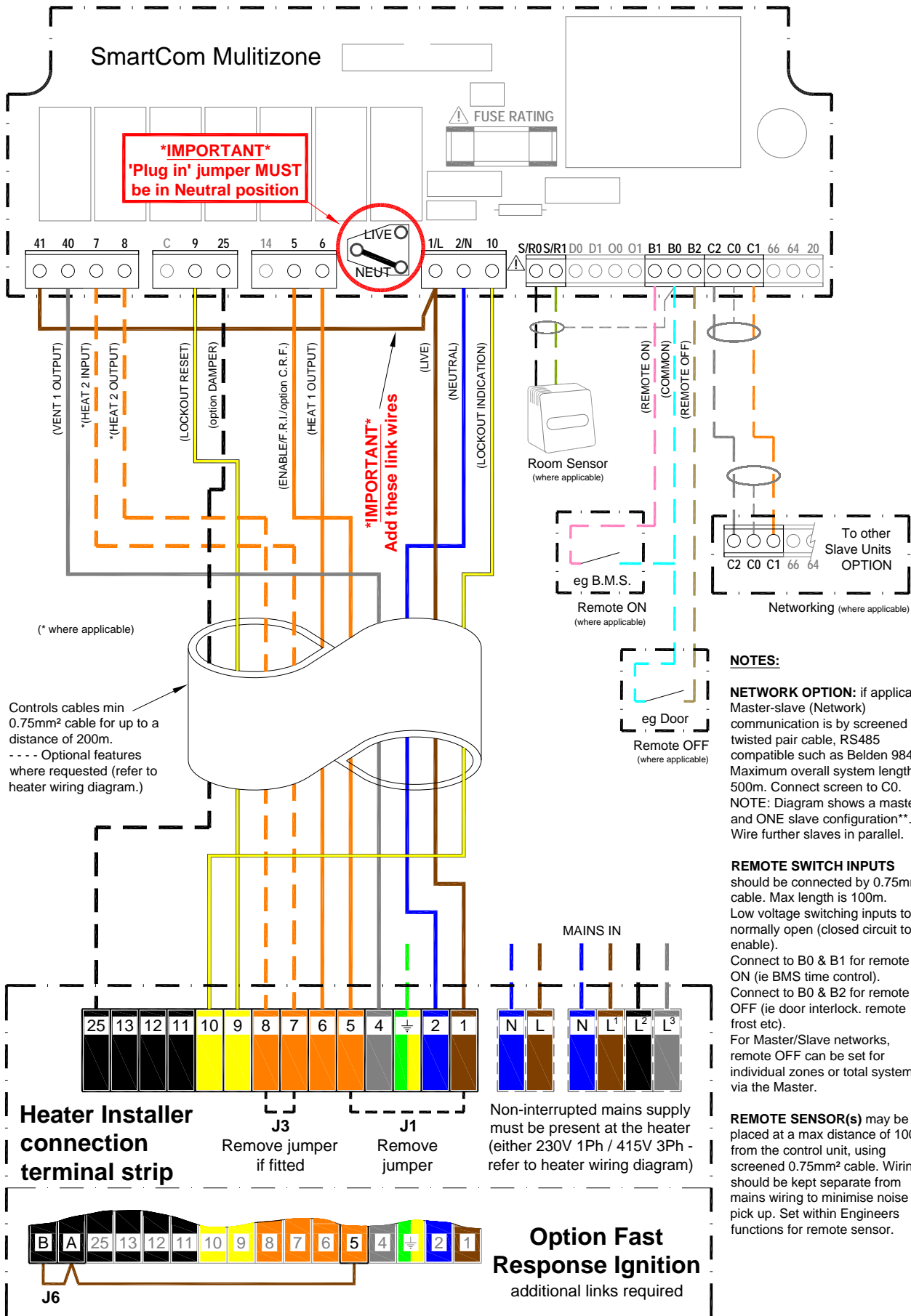

14 Modulation ST Heaters with Autospark ignition to remote SmartCom³ MZ (or Network).

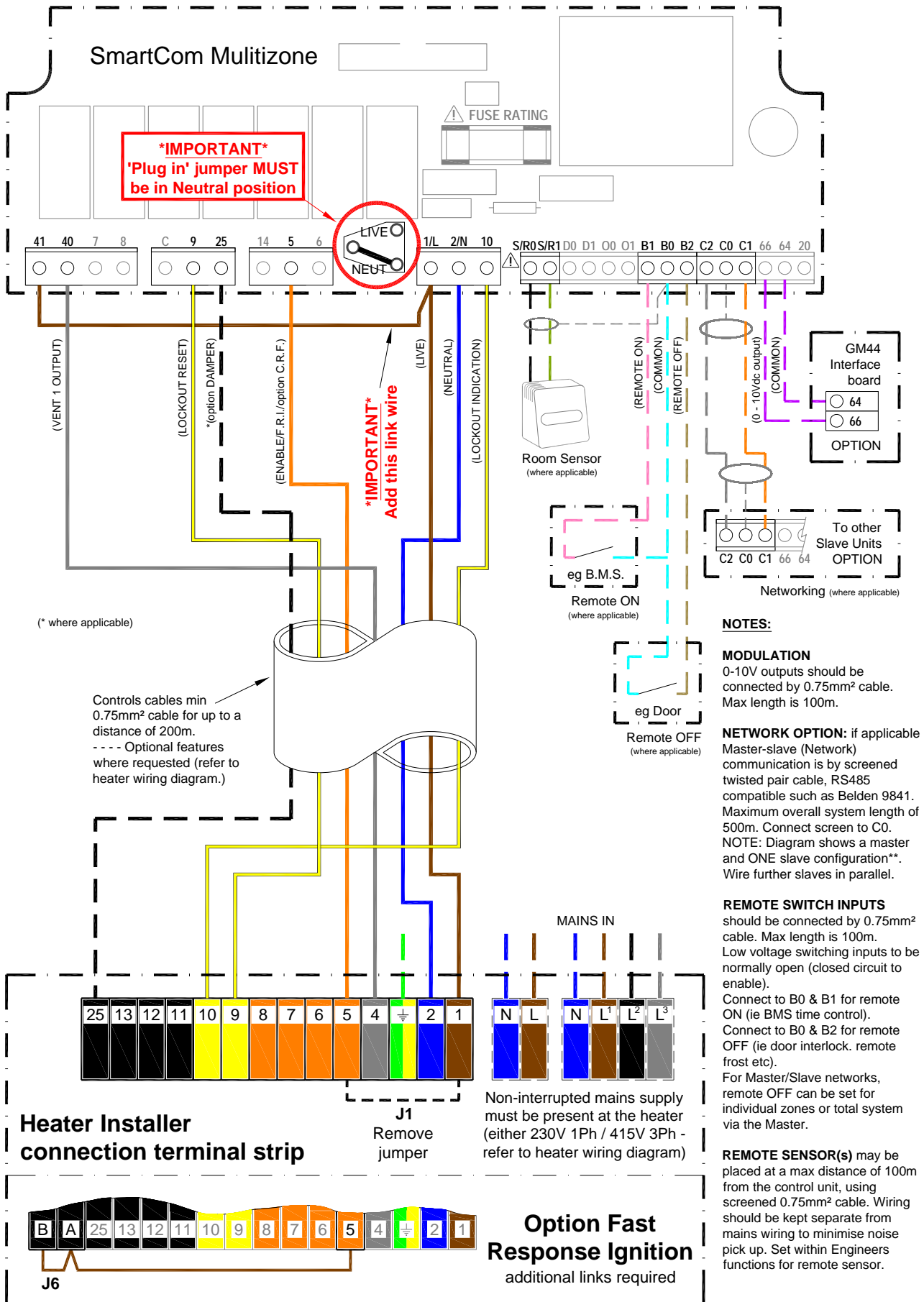

15 Single Stage (on/off) Heaters with Thermoelectric (permanent pilot) to remote SmartCom³ SZ.

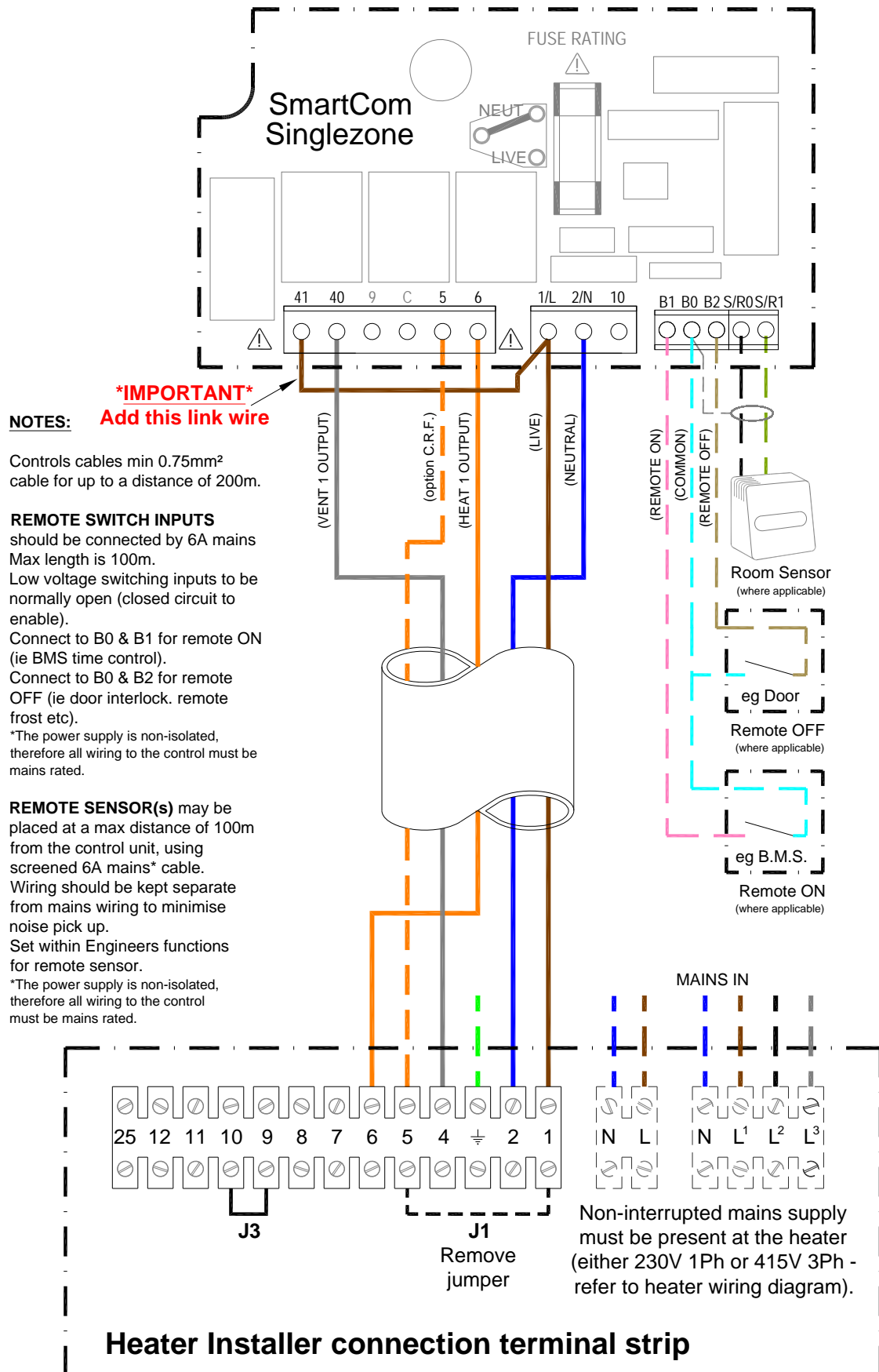

16 Two Stage (hi/low) Heaters with Thermoelectric (permanent pilot) to remote SmartCom³ MZ (or Network).

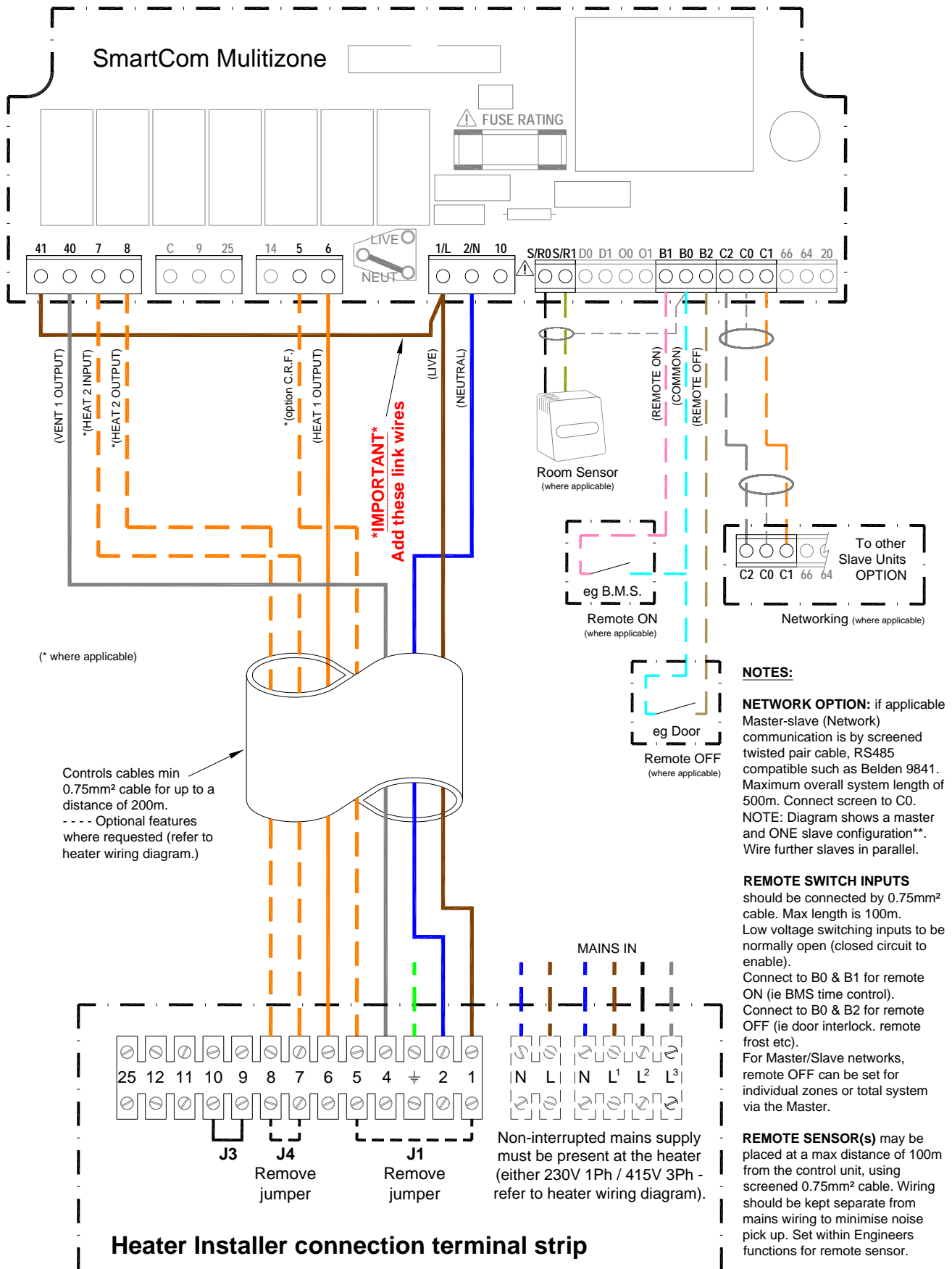

17 Modulation Heaters with Thermoelectric (permanent pilot) to remote SmartCom³ MZ (or Network).

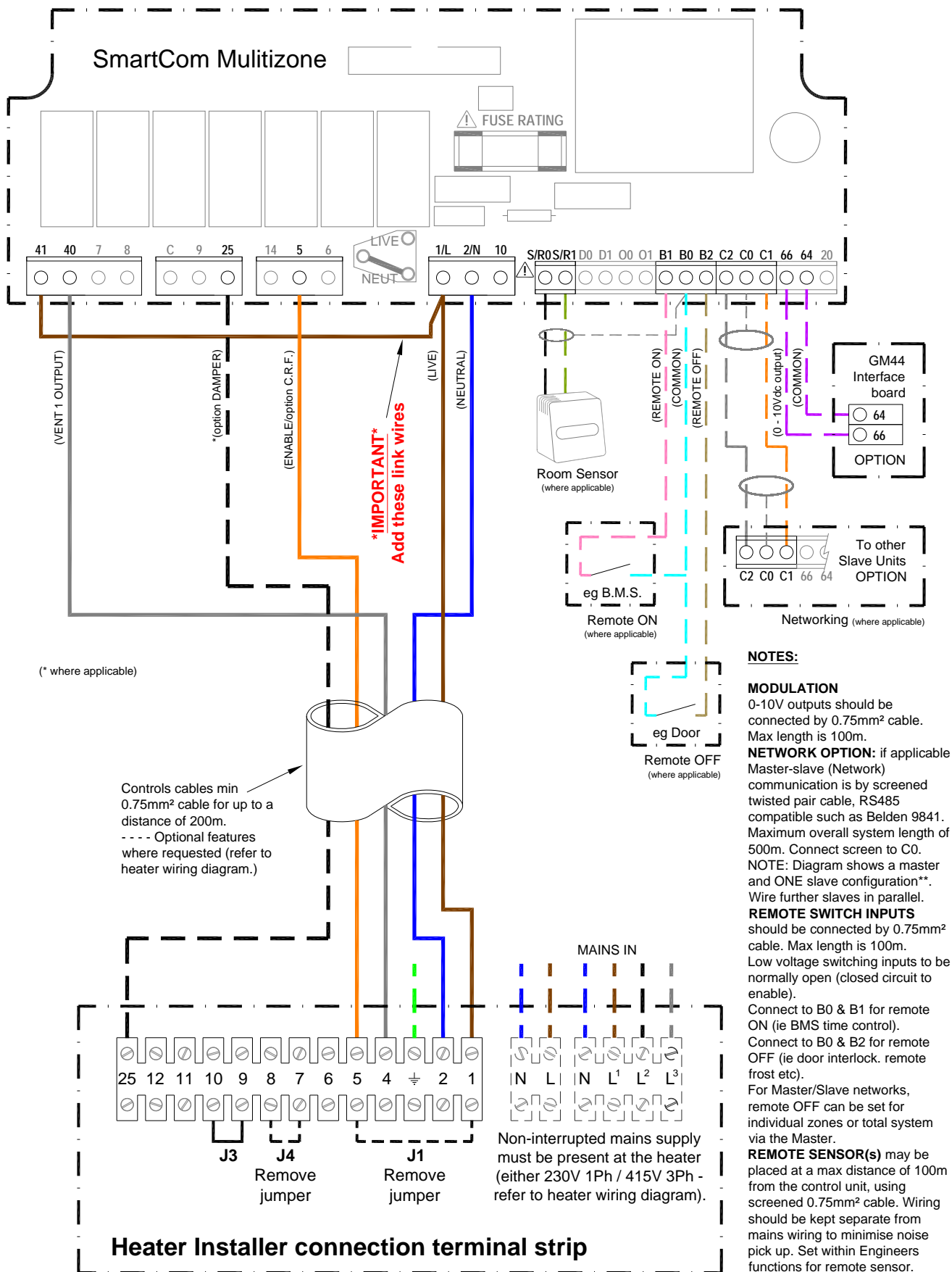

18 Modulation ULSA Heaters with Autospark ignition to remote SmartCom³ MZ.

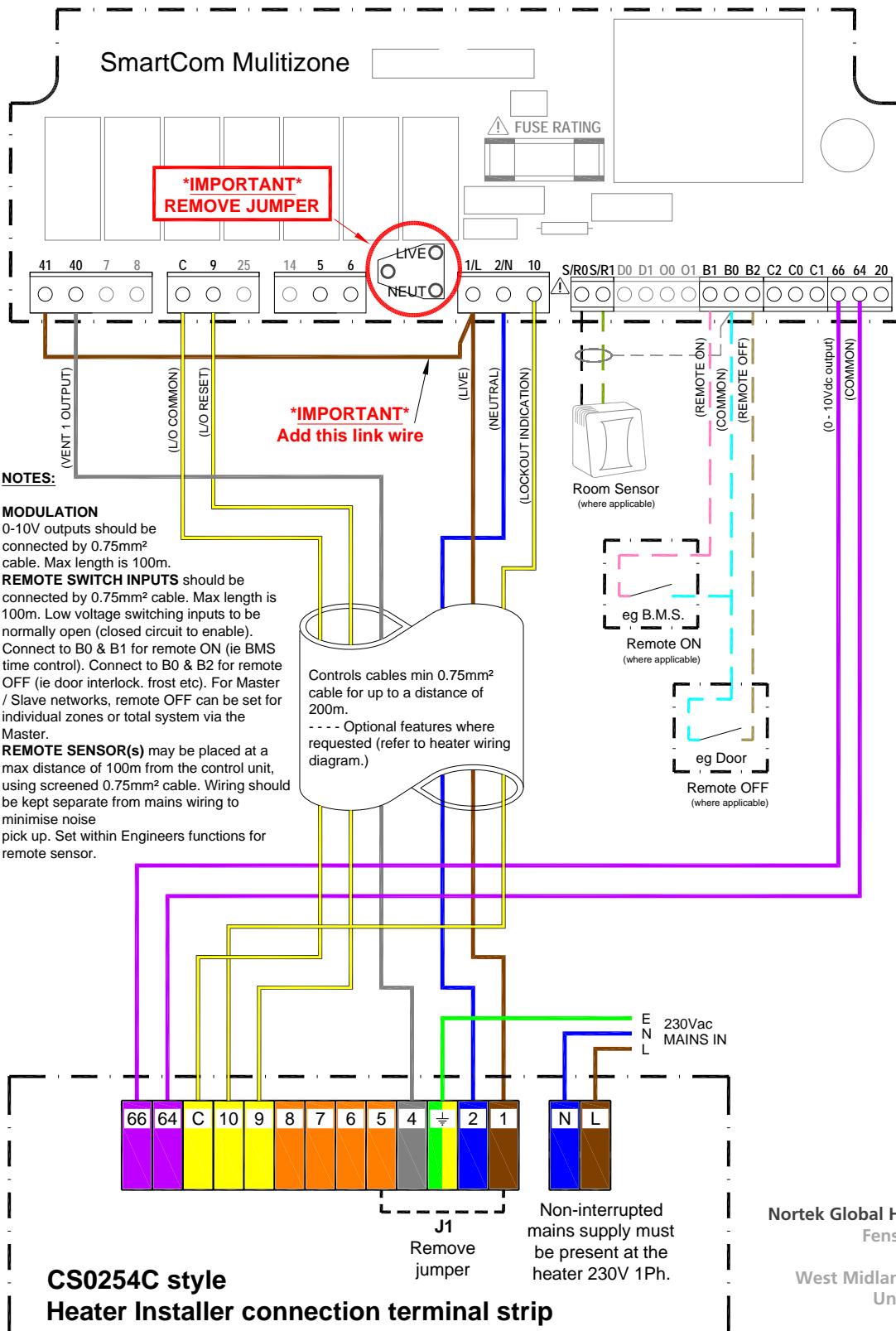

Nortek Global HVAC (UK) Ltd
Fens Pool Avenue
Brierley Hill
West Midlands DY5 1QA
United Kingdom

Tel: 01384 489250
Fax: 01384 489707

ambiradsales@nortek.com
www.ambirad.co.uk



AMBIRAD AIRBLOC NORDAIRNICHE BENSON

Registered in England No. 1390934. Registered office: 10 Norwich Street, London, EC4A 1BD

Nortek Global HVAC is a registered trademark of Nortek Global HVAC Limited. Because of continuous product innovation, Nortek Global HVAC reserves the right to change product specification without due notice.

Document reference number GB/SCOM/121/0915
Replaces GB/SCOM/121/1114